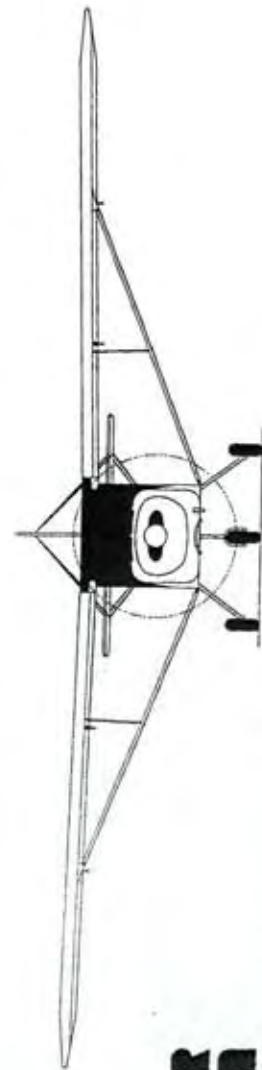
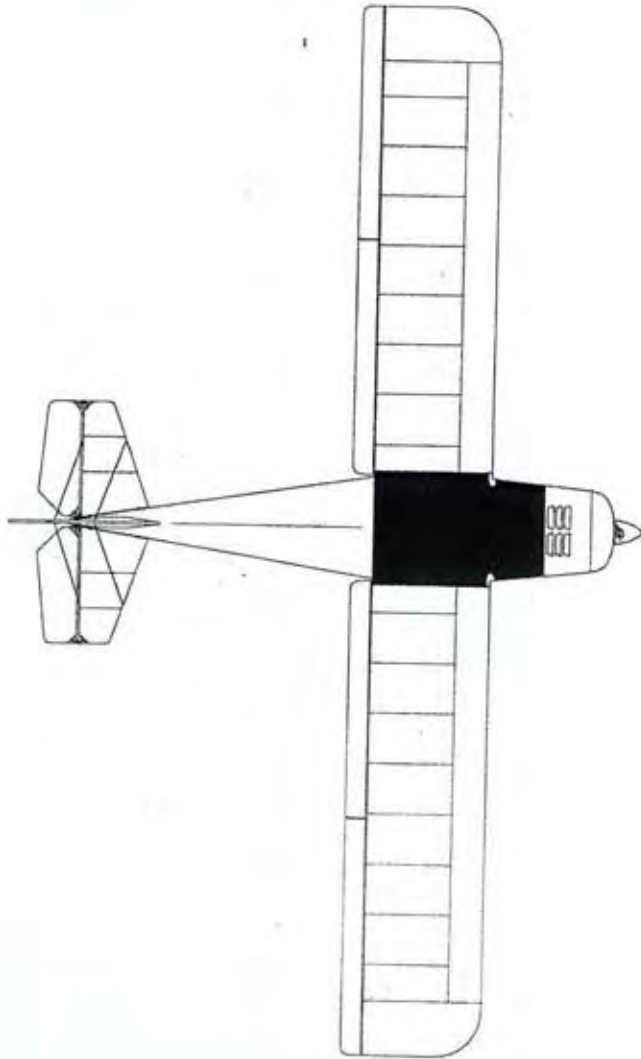
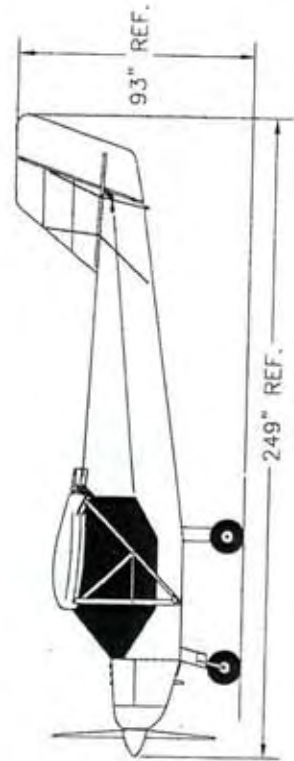
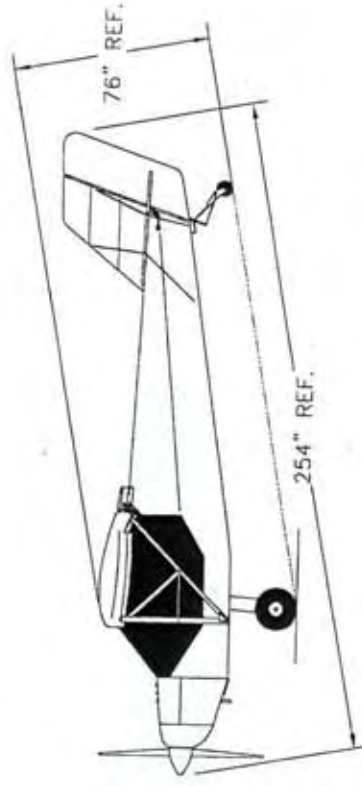
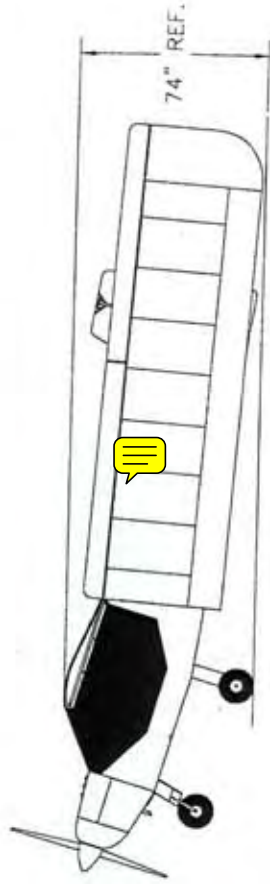
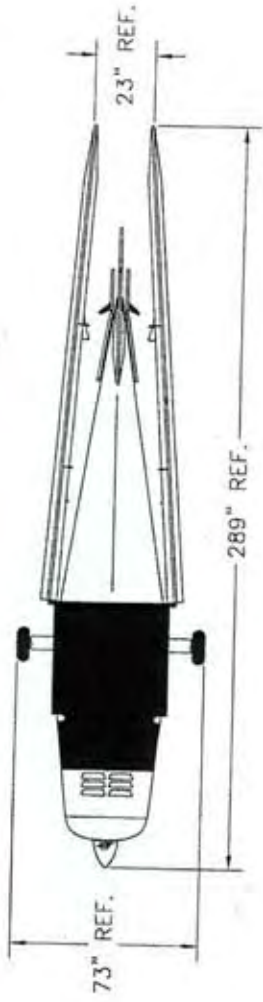


# RANS S-6ES COYOTE II

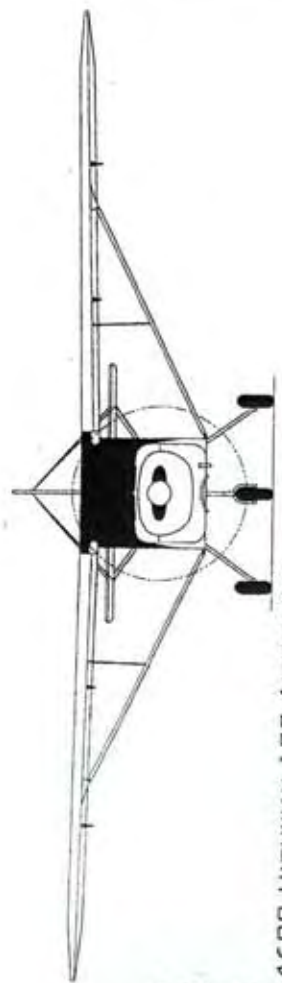
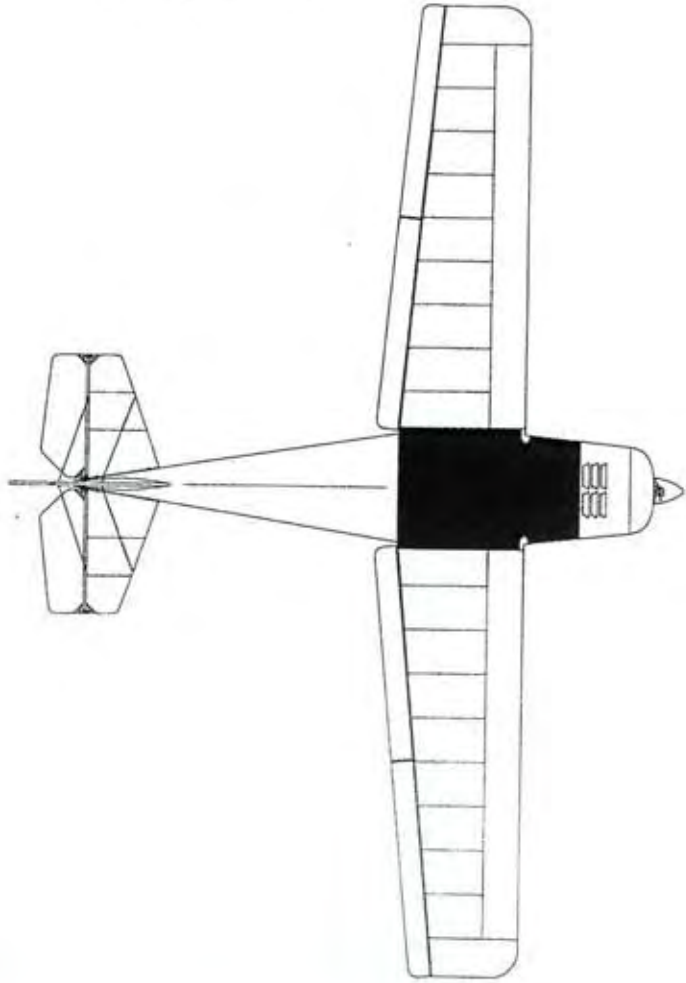
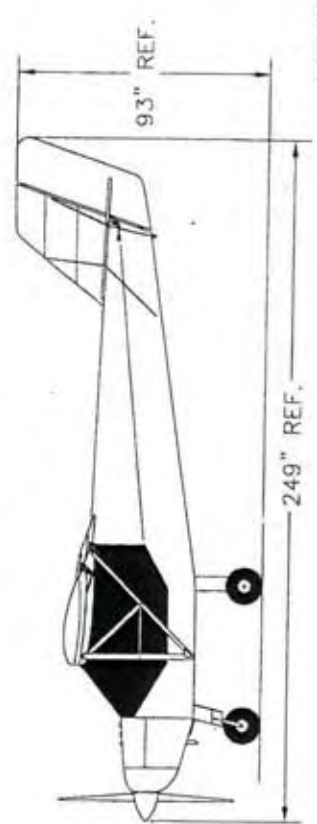
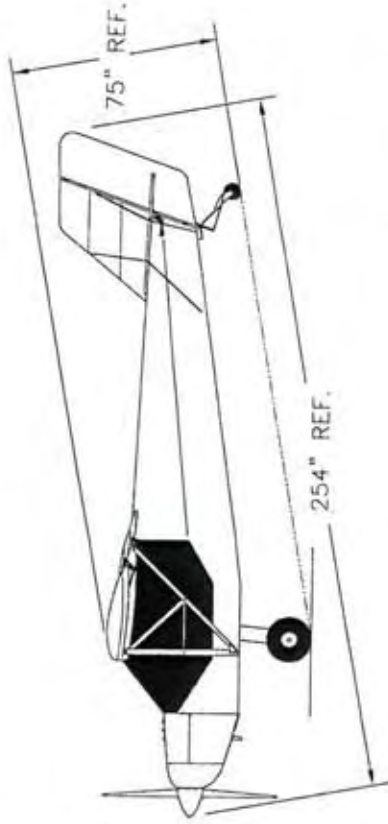
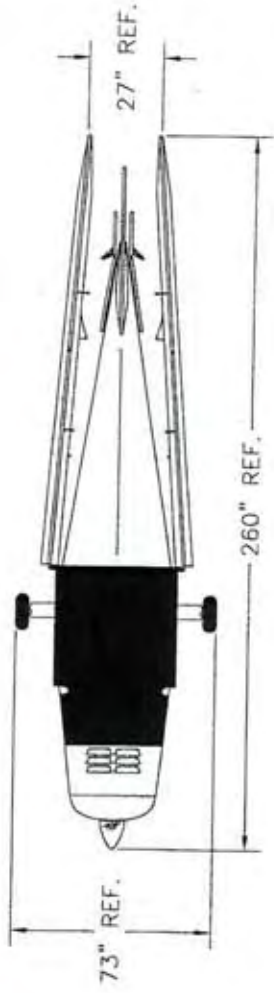


4600 HIGHWAY 183 ALTERNATE  
HAYS, KS 67601  
(785) 625-6346



DESIGNED BY:  
RANDY SCHLITZER

# JRANS S-6ES COYOTE II 116 WING



4600 HIGHWAY 183 ALTERNATE  
HAYS, KS 67601  
(785) 625-6346

DESIGNED BY:  
RANDY SCHLITZER

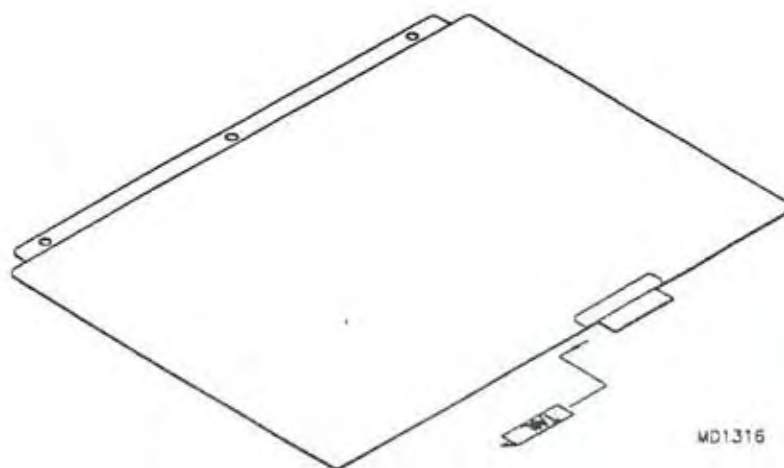
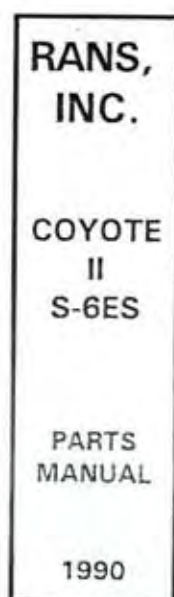
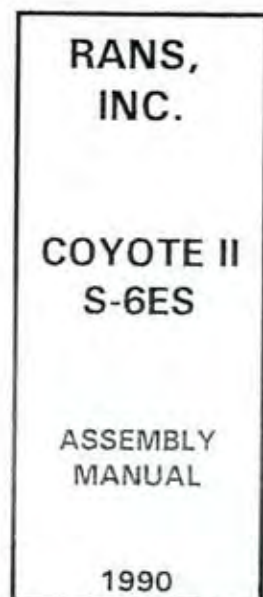


# HOW TO ASSEMBLE YOUR S-6ES COYOTE II TECHNICAL MANUAL

Your manual is ready for assembly:

1. Every section begins with the parts pages, followed by the text. Every page has a section number then a page number within that section. (Example: parts page 13-2) Parts pages have an exploded view and a parts listing, these are assigned with the prefix "00". Text pages are assigned with the prefix "0".
2. Separate the sections with the tab inserts listed below. Follow the table of contents for the order that the manual should follow.
3. Cut out and slip in the labels to corresponding sections.

GENERAL DATA	S-1 FIREWALL	BRAKES	FUEL SYSTEM	COVERING
GENERAL DATA	S-1 FIREWALL	BRAKES	FUEL SYSTEM	COVERING
FUSELAGE	AILERON/FLAPS	ENGINE MOUNT	WINDSHIELD	CG/OPERATIONS
FUSELAGE	AILERON/FLAPS	ENGINE MOUNT	WINDSHIELD	CG/OPERATIONS
MAIN GEAR	SEAT/SEAT BELT	ENGINE	COWLING	OPTIONS
MAIN GEAR	SEAT/SEAT BELT	ENGINE	COWLING	OPTIONS
NOSE GEAR/ TAILWHEEL	TAILCONE	ENGINE COOLING SYSTEM	RUDDER	
NOSE GEAR/ TAILWHEEL	TAILCONE	ENGINE COOLING SYSTEM	RUDDER	
FLOORBOARD/ RUDDER PEDAL	DOORS	INSTR. PANEL/ ELECTRICAL	WINGS	
FLOORBOARD/ RUDDER PEDAL	DOORS	INSTR. PANEL/ ELECTRICAL	WINGS	
CONTROL STICK	TAIL	THROTTLE	116 WINGS	
CONTROL STICK	TAIL	THROTTLE	116 WINGS	



MD1316

RIVETS CROSS REFERENCE LIST

DIA.	POP RIVET					CHERRY O				
	RANS NO.	NO.	SHER.	TNSL.	GRIP	NO.	SHER.	TNSL.	GRIP	
3/32 (#41)	40APR1/8	AD32ZABS	85	135	.031-.125	--	--	--	--	
3/32 (#41)	40APR1/4	AD34ABS	85	135	.126-.250	--	--	--	--	
3/32 (#41)	40APR3/8	AD36ABS	85	135	.251-.375	--	--	--	--	
1/8 (#30)	30APR1/16	--	--	--	--	AAPO-41	225	250	.0-.062	
1/8 (#30)	30APR1/8	AD42ABS	155	235	.063-.125	AAPO-42	225	250	.063-.125	
1/8 (#30)	30APR1/4	AD44ABS	155	235	.188-.250	AAPO-44	225	250	.126-.250	
1/8 (#30)	30APR3/8	AD46ABS	155	235	.313-.375	AAPO-46	225	250	.251-.375	
1/8 (#30)	30SSPR1/16	--	--	--	--	CCPO-41	700	600	0-.062	
1/8 (#30)	30SSPR1/8	SSD42SSBS	550	700	.031-.125	CCPO-42	700	600	.063-.125	
1/8 (#30)	30SSPR1/4	SSD44SSBS	550	700	.188-.250	CCPO-45	700	600	.188-.312	
1/8 (#30)	30SSPR3/8	SSD46SSBS	550	700	.251-.375	CCPO-46	700	600	.251-.375	
3/16 (#11)	12APR1/8	AD62ABS	315	500	.063-.125	AAPO-62	500	450	.062-.125	
3/16 (#11)	12APR1/4	AD64ABS	315	500	.126-.250	AAPO-64	500	450	.126-.250	
3/16 (#11)	12APR3/8	--	--	--	--	AAPO-66	500	450	.251-.375	
3/16 (#11)	12APR1/2	AD68ABS	315	500	.375-.500	AAPO-68	500	450	.376-.500	
3/16 (#11)	12SSPR1/8	--	--	--	--	CCPO-62	1650	1300	.062-.125	
3/16 (#11)	12SSPR1/4	SSD64SSBS	1000	1375	.126-.250	CCPO-64	1650	1300	.126-.250	
3/16 (#11)	12SSPR3/8	SSD66SSBS	1000	1375	.251-.375	CCPO-66	1650	1300	.251-.375	
3/16 (#11)	--	--	--	--	--	SSPO-68	1050	825	.376-.50	
3/16 (#11)	--	--	--	--	--	SSPO-610	1050	825	.501-.625	
1/8"	--	--	--	--	--	CCPO-44	700	600	.126-.250	
1/8 (#30)	--	--	--	--	--	AVEX RIVET				
						1691-0410	165	230	.031-.187	

# AN Bolt Gauge

— 3	— 3	— 4	— 5	— 6	— 7	— 8	— 9	— 10
— 4	— 4	— 4	— 5	— 6	— 7	— 8	— 9	— 10
— 5	— 5	— 5	— 6	— 7	— 8	— 9	— 10	— 11
— 6	— 6	— 6	— 7	— 8	— 9	— 10	— 11	— 12
— 7	— 7	— 7	— 8	— 9	— 10	— 11	— 12	— 13
— 10	— 10	— 10	— 11	— 12	— 13	— 14	— 15	— 16
— 11	— 11	— 11	— 12	— 13	— 14	— 15	— 16	— 17
— 12	— 12	— 12	— 13	— 14	— 15	— 16	— 17	— 18
— 13	— 13	— 13	— 14	— 15	— 16	— 17	— 18	— 19
— 14	— 14	— 14	— 15	— 16	— 17	— 18	— 19	— 20
— 15	— 15	— 15	— 16	— 17	— 18	— 19	— 20	— 21
— 16	— 16	— 16	— 17	— 18	— 19	— 20	— 21	— 22
— 17	— 17	— 17	— 18	— 19	— 20	— 21	— 22	— 23
— 20	— 20	— 20	— 21	— 22	— 23	— 24	— 25	— 26
— 21	— 21	— 21	— 22	— 23	— 24	— 25	— 26	— 27
— 22	— 22	— 22	— 23	— 24	— 25	— 26	— 27	— 28
— 23	— 23	— 23	— 24	— 25	— 26	— 27	— 28	— 29
— 24	— 24	— 24	— 25	— 26	— 27	— 28	— 29	— 30
— 25	— 25	— 25	— 26	— 27	— 28	— 29	— 30	— 31
— 26	— 26	— 26	— 27	— 28	— 29	— 30	— 31	— 32
— 27	— 27	— 27	— 28	— 29	— 30	— 31	— 32	— 33
— 30	— 30	— 30	— 31	— 32	— 33	— 34	— 35	— 36
— 31	— 31	— 31	— 32	— 33	— 34	— 35	— 36	— 37
— 32	— 32	— 32	— 33	— 34	— 35	— 36	— 37	— 38
— 33	— 33	— 33	— 34	— 35	— 36	— 37	— 38	— 39
— 34	— 34	— 34	— 35	— 36	— 37	— 38	— 39	— 40
— 35	— 35	— 35	— 36	— 37	— 38	— 39	— 40	— 41
— 36	— 36	— 36	— 37	— 38	— 39	— 40	— 41	— 42
— 37	— 37	— 37	— 38	— 39	— 40	— 41	— 42	— 43
— 40	— 40	— 40	— 41	— 42	— 43	— 44	— 45	— 46
— 41	— 41	— 41	— 42	— 43	— 44	— 45	— 46	— 47
— 42	— 42	— 42	— 43	— 44	— 45	— 46	— 47	— 48
— 43	— 43	— 43	— 44	— 45	— 46	— 47	— 48	— 49
— 44	— 44	— 44	— 45	— 46	— 47	— 48	— 49	— 50
— 45	— 45	— 45	— 46	— 47	— 48	— 49	— 50	
— 46	— 46	— 46	— 47	— 48	— 49	— 50		
— 47	— 47	— 47	— 48	— 49	— 50			
— 50	— 50	— 50	— 50					
<b>AN3</b>	<b>AN4</b>	<b>AN5</b>	<b>AN6</b>	<b>AN7</b>	<b>AN8</b>	<b>AN9</b>	<b>AN10</b>	
<b>3/16</b>	<b>1/4</b>	<b>5/16</b>	<b>3/8</b>	<b>7/16</b>	<b>1/2</b>	<b>9/16</b>	<b>5/8</b>	

# AN3 - AN8 AIRFRAME BOLTS

## AN3-AN8 CADMIUM-PLATED STEEL BOLTS (DRILLED AND UNDRILLED)

A non-corrosion-resistant steel machine bolt which conforms to Specification MIL-B-6812. Cadmium-plated to Specification QQ-P-416.

Available with or without single hole through shank and/or single hole through head. Examples of part members for a cadmium plated steel bolt having a diameter of 1/4" and nominal length of 1".

AN4-6	For drilled shank
AN4-6A	Designates undrilled shank
AN4H-6	Drilled head, drilled shank
AN4H-6A	Drilled head, undrilled shank

### NUT AND COTTER PIN SIZES

AN NUMBER	DIAMETER	PLAIN NUT AN NUMBER	CASTLE NUT AN NUMBER	COTTER PIN MS NUMBER
AN3	3/16	AN315-3R	AN310-3	MS24665-132
AN4	1/4	AN315-4R	AN310-4	MS24665-132
AN5	5/16	AN315-5R	AN310-5	MS24665-132
AN6	3/8	AN315-6R	AN310-6	MS24665-283
AN7	7/16	AN315-7R	AN310-7	MS24665-283
AN8	1/2	AN315-8R	AN310-8	MS24665-283

### HOW TO DETERMINE GRIP For Steel and Aluminum Aircraft Bolts (Subtract Fractions Shown Below From Length of Bolt)

AN 3 to AN 8	AN NUMBER, Diameter, and Threads per Inch	AN3 10 -32	AN4 1/4 -28	AN5 5/16 -24	AN6 3/8 -24	AN7 7/16 -20	AN8 1/2 -20
	Grip = Length Less . . . . .	13/32	15/32*	17/32	41/64	21/32	25/32

\*Formula does not apply for AN4-3. Grip for AN4-3 is 1/16.

### DASH NUMBER -- NOMINAL LENGTH

-3 . . . 3/8	-6 . . . 3/4	-11 . . . 1 1/2	-14 . . . 1 1/2	-17 . . . 1 7/8	-22 . . . 2 1/4	-25 . . . 2 5/8
-4 . . . 1/2	-7 . . . 7/8	-12 . . . 1 1/4	-15 . . . 1 5/8	-20 . . . 2	-23 . . . 2 3/8	-26 . . . 2 3/4
-5 . . . 5/8	-10 . . . 1	-13 . . . 1 3/8	-16 . . . 1 3/4	-21 . . . 2 1/8	-24 . . . 2 1/2	-27 . . . 2 7/8
						-30 . . . 3

### PART IDENTIFICATION

Use the above chart to determine lengths of bolts. Diameters are as follows:

AN3 = 3/16"      AN4 = 1/4"      AN5 = 5/16"      AN6 = 3/8"

Use the parts manual for other part identification. The drawings depict a fairly accurate likeness of the real thing. Other parts are labeled by part number. Again, reference the parts manual to confirm part identity.

S-6ES COYOTE II

## TABLE OF CONTENTS

<u>System</u>	<u>Section</u>
General Information	00
Fuselage	01
Main Gear	02
Nose Gear/Tailwheel	03
Floorboard/Rudder Pedals	04
Control Stick	05
S-1 Firewall	06
Aileron/Flaps	07
Seat/Seat Belt	08
Tailcone	09
Doors	010
Tail	011
Brakes	012
Engine Mount	013
Engine	014
Engine Cooling System	015
Instrument Panel/Electrical	016
Throttle	017
Fuel System	018
Windshield	019
Cowling	020
Rudder	021
Wings	022
116 Wing	022C
Covering	023
CG/Operations	024
Options	025

# **RANS INC.**

4600 Highway 183 Alternate  
Hays, KS 67601

Technical Support  
(785) 625-0069

Parts Department  
(785) 625-6346

When calling Technical Support please have the following ready:

- Aircraft Model
- Serial Number
- Engine Model
- Your Aircraft Assembly Manual

Note: Please make your questions precise and to the point so that we may assist as many customers as possible.



# RANS Aircraft

## Tool List

This is a partial list of tools that would be helpful when assembling a RANS airplane.

### *Hand Tools*

Pliers	Safety wire pliers
Needle nose pliers	Linesman pliers
Side cutters	Electrical wire strippers
Aviation snips	Pop rivet tool
Hammer	Click punch
Rubber mallet*	Ball peen hammer
Center punch	Scratch awl
Drift pin and punch set	Screwdriver set
Several small clamps	Safety glasses
Wrench set SAE and metric	Socket set SAE and metric
Ruler and tape measure	2 or 4 ft. Level
Adjustable fly cutter*	Utility knife
Set of drill bits	Hole saw*
Hack saw	Files

### *Power Tools*

Electric hand drill	Small electric grinder*
Dremel*	Bench disk sander*
Soldering gun	Heat gun*
CD/MP3 Player*	

### *Lubricants and Glues*

Small can lithium grease	Clear silicone
Contact cement	WD 40
Super glue	Wheel Bearing Grease
3M DP-460 Epoxy Adhesive	3M DP-460 Epoxy Mixer Tips
Acrylic Foam Tape (double sided)	

\* Not a necessary tool but helpful.

# RANS Aircraft

## RECOMMENDED AVIONICS LIST – S-6ES

### **Comm Radios**

KING	KLX-135A GPS/COM with moving map
ICOM	IC-A200 Transceiver

### **Transponder**

KING	KT-76A Transponder
------	--------------------

### **Encoder**

Trans-Cal	SSD-120-30 Altitude Encoder
-----------	-----------------------------

### **Intercom**

PS Engineering	PM1000 II Intercom	(RANS “pre-cut” panels are designed for this intercom)
----------------	--------------------	--

### **ELT**

ACK Technologies	ELT Model E-01
------------------	----------------

### **Push to Talk Switch**

Radio Shack	#275-644 Pushbutton Switch
-------------	----------------------------

### **Noise Filter**

Radio Shack	#270-055 20-Amp Noise Filter
-------------	------------------------------

Local Avionic shops can wire your avionic harnesses for you.

Wells Aircraft does the wiring harnesses for the RANS Fleet. Contact George at 620-663-1546 for details.

### **WELLS AIRCRAFT\***

P.O. BOX 858

HUTCHINSON, KS 67504

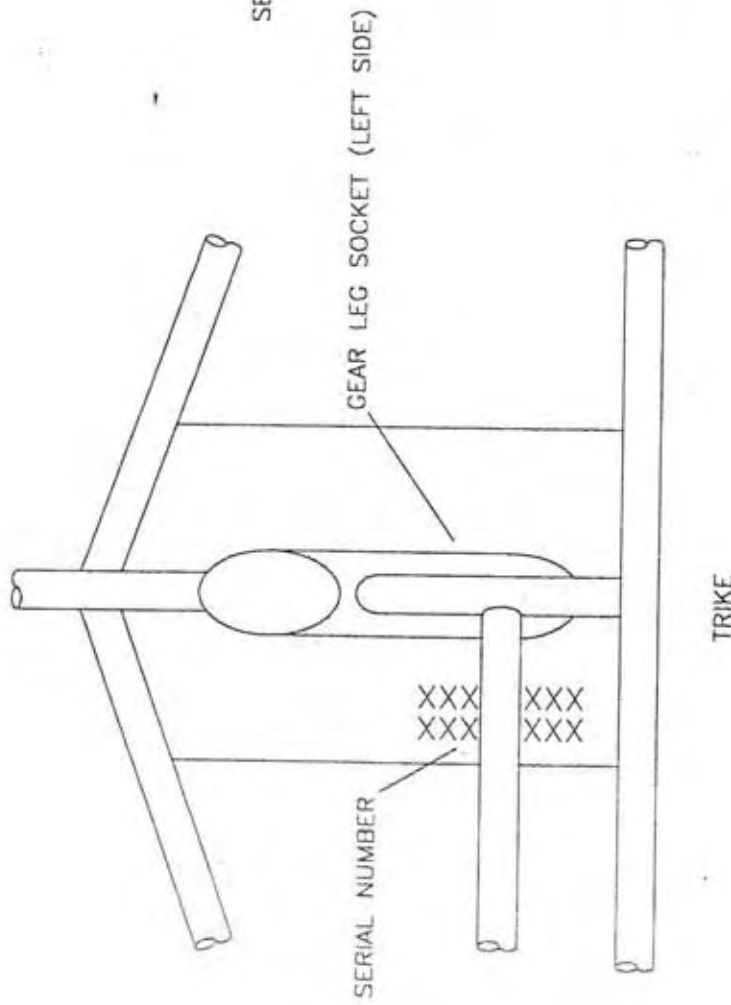
\*Authorized Bendix/King dealer

Switches, circuit breakers, and other electrical parts are also available for RANS aircraft panels.

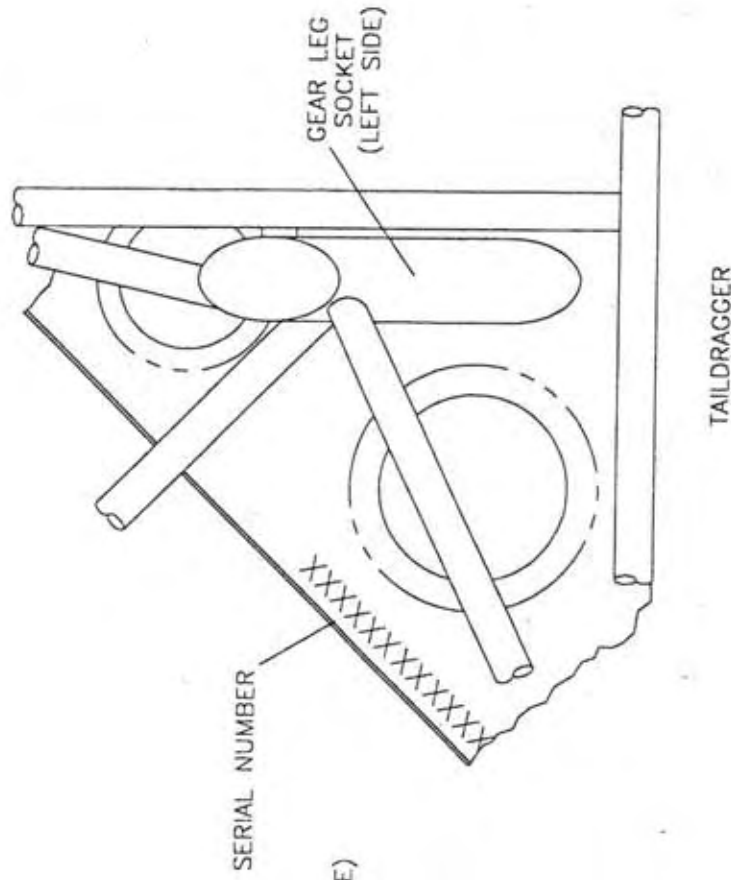
Contact RANS Parts Department for pricing.

RED Illuminated Master Switch	KSES0017
Non-illuminated Switch	KSES0016
Panel Post Lights	KSES0018
Electrical Buss Bar	AMW 636
W58 Circuit Breakers	
1 amp	KSES0010
2 amp	KSES0012
4 amp	KSES0014
5 amp	KSES0015
10 amp	KSES0013
15 amp	KSES0011

TOP VIEW



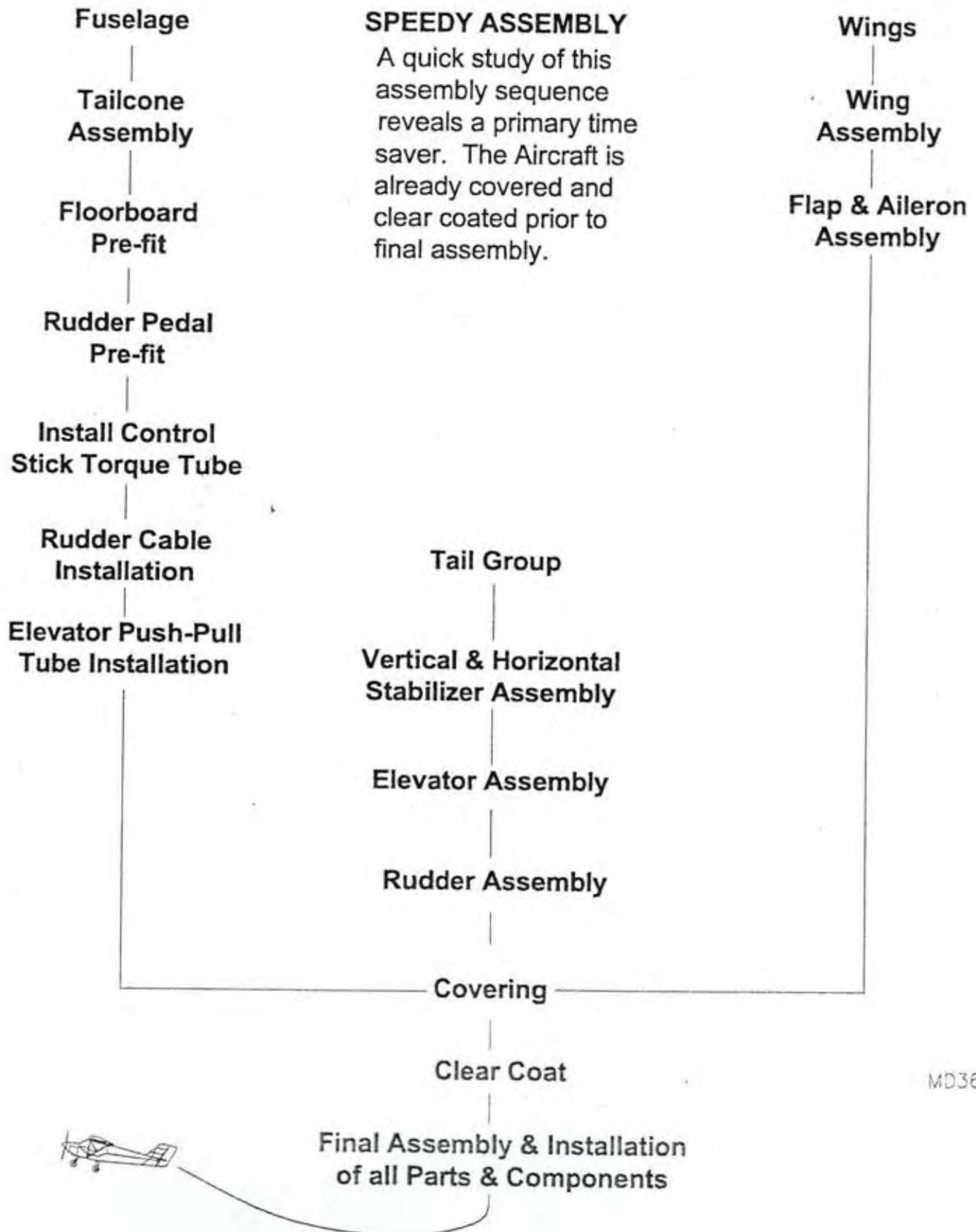
TOP VIEW



MD1315

**RRRND S-6ES COYOTE II**  
**SERIAL PLATE LOCATION**

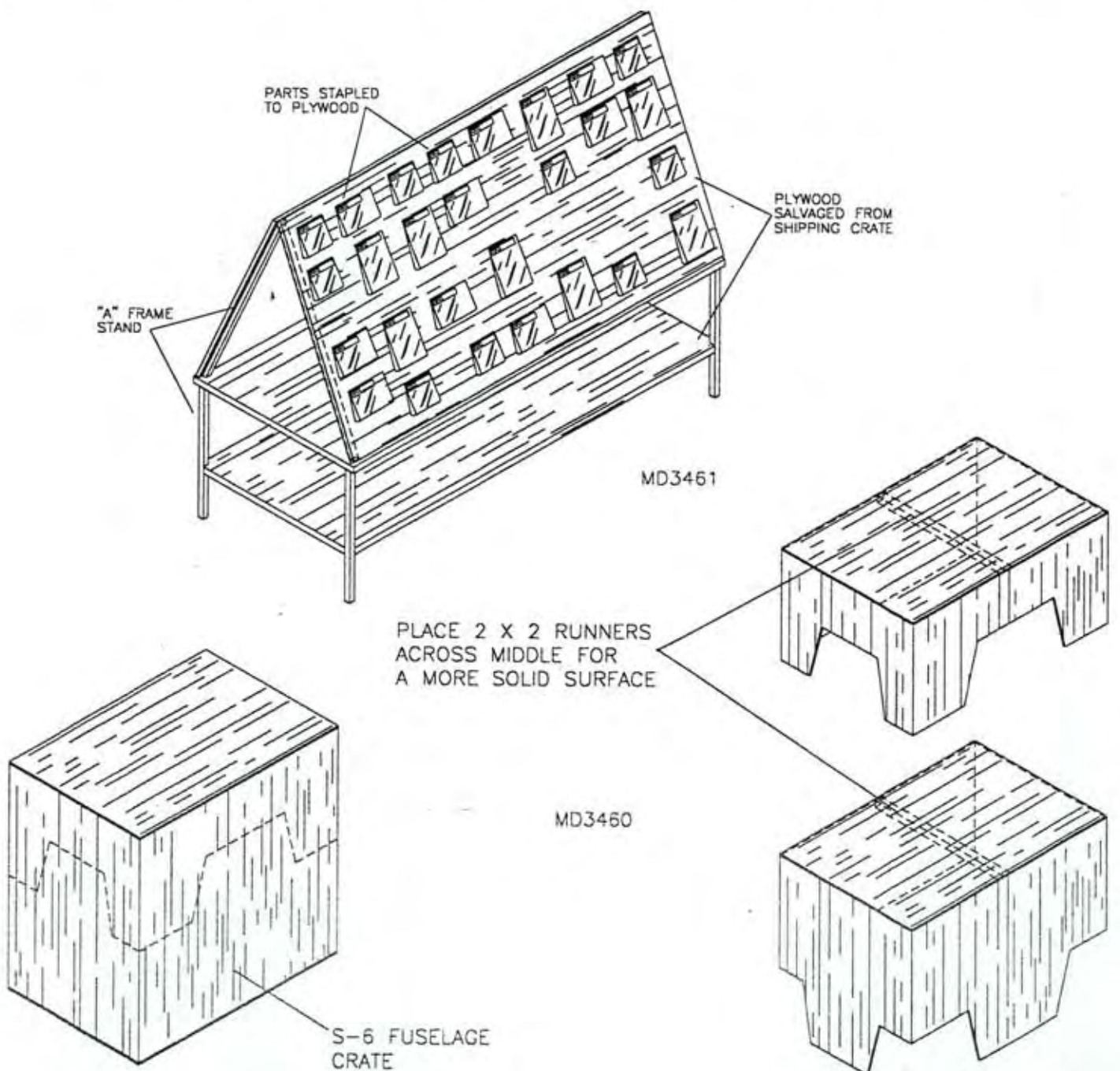
# RANS S-6ES COYOTE II ASSEMBLY SEQUENCE



MD3625

## S-6ES COYOTE II GENERAL INFORMATION

**TAKE INVENTORY:** You must complete an inventory within 60 days of receiving your kit. We check and re-check and are 99.9% certain that if we say we shipped it, we did. The first task in building your kit is to inventory the parts using the packing list provided. It's your job to keep all parts organized and accounted for. We can not provide missing parts cost free after 60 days. Use the supplied pack list to verify that everything that we packed is in the box. The fast way to inventory, is to use the Priority Number that appears on the Part Number labels, these will match the pack list in numeric order. Go through the list item by item. If anything is not there that should be, please contact our parts department immediately. **HINT:** Use sections of plywood from the packing crate to fabricate a part inventory board. As each part is inventoried and checked off on the pack list, staple the bag to the board. This allows for quick identification and part selection during assembly. We fabricate "A" Frame stands to support the plywood. Refer to the figure below. Plywood can also be attached to shop wall. Two work benches can also be fabricated out of the fuselage crate by making the cuts as shown in the figure below.



**BEFORE BEGINNING:** Please read the manual cover to cover. This will speed up your build time considerable. Refer to the assembly sequence flow chart .

**GET ORGANIZED:** Prepare your workshop and be sure that what goes in the shop door will be able to come out!

**KEEP IT CLEAN!** The pre-sewn skins can soil easily. Wash your hands, tools and work tables. You will notice many of the parts are marked with part numbers. These wipe off with a cloth dampened with acetone or lacquer thinner. **CAUTION:** Do not allow acetone, lacquer thinner or loctite to come in contact with the lexan glazing. These and some other solvents will destroy the lexan.

After drilling holes they will need to be deburred. This is an IMPORTANT step and must be performed. Assembly of the parts with burrs can cause stress risers and eventual part failure. Various tools can be used. An official deburring tool is nice, but a ½" drill bit can do a good job on most holes. Radius and smooth sharp corners with files or fine grit sanders and grinders. Edges of certain parts also need deburring...a good file works here.

A few special tools will be needed. A power drill, wrenches and a pop riveter. "Clecocos" make trial fitting and assembly go smooth on assemblies such as windows, cowling and firewall.

**FABRICATED PARTS:** You will need to fabricate some parts out of the raw stock. These parts will be identified in your assembly manuals.

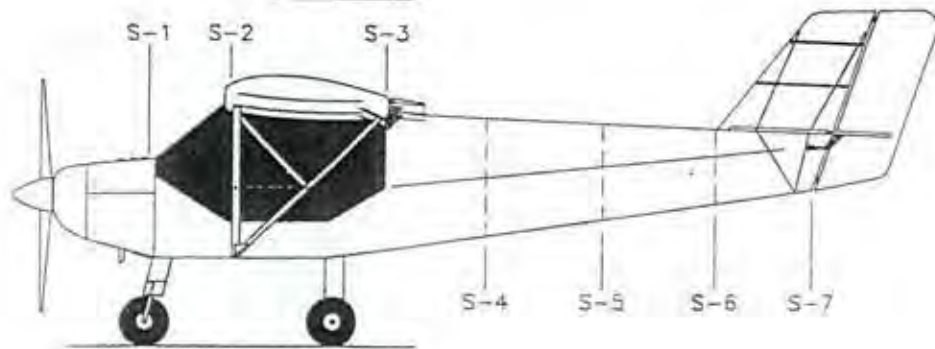
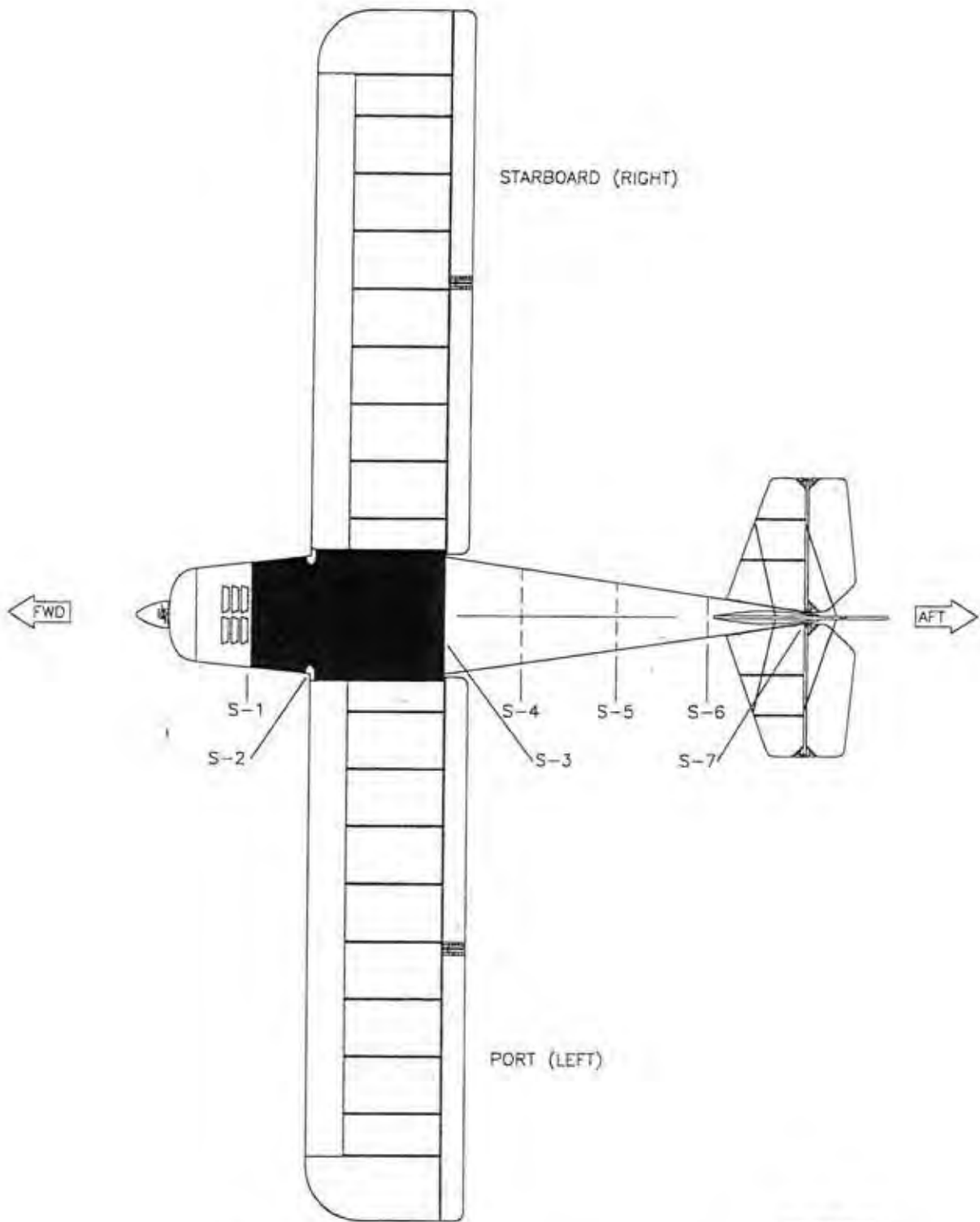
**STRUCTURAL STATIONS:** Throughout the manual references will be made to structural stations. These are locations of formers or bulkheads from the nose to the tail of the aircraft. Observe the drawing in this section for locations.

**CLECOS:** Included in your kit is a supply of clecocos. These are temporary fasteners that will be used to hold things together while fitting and drilling. A pliers is also included to install and remove the clecocos. The clecocos are color coded as to hole size. Silver #40 Copper #30 Gold #11

To use, simply set the cleco in the special pliers, squeeze closed, insert into the hole and release. (Reverse for removal). You will find the clecocos to be extremely useful throughout assembly.

**RIVETS:** Your kit is supplied with various sizes of aluminum and stainless steel pop rivets. Even though we are careful, there is always the chance of the packages being mis-labeled. So before riveting, be sure to double check that you have the correct aluminum or stainless steel pop rivet for the particular section you are working on.

**ROD ENDS:** When installing rod ends and similar hardware, be certain at least ten threads are engaged, unless instructed otherwise within the text.



MD1458

## WARRANTY INFORMATION

KODIAK RESEARCH, INC.  
P.O. BOX N7113  
MARLBOROUGH HOUSE  
CUMBERLAND ST.  
NASSAU, N.P. BAHAMAS

PHONE: (809) 356-5377  
FAX: (305) 776-9908

Attn: O.E.M.'s

Date: October 31, 1991

Subject: Warranty Extension Requests

Dear Customer: (RANS, Inc.)

- 1) In order for your customers (the builder) to receive their six month full warranty from time of first use, you must submit for extension on the enclosed form (please add your letterhead to this form). If no request is received, warranty will begin from the date the invoice was sent to your customer (the builder).
- 2) Extension will be required for any warranty outside the original six month period. This must be submitted prior to any claim or failure and cannot be applied retro-actively.
- 3) Supply a copy of original customer request and reason for same as per guideline, submit with your verification on request form.
- 4) All requests must be submitted by manufacturer only. Any request for extensions from retail customers direct will be forwarded to the O.E.M. to process in the above format.

If you have any problem understanding this policy, please call for clarification.



## CALCULATING WARRANTY

### "When does the warranty start?"

1. The final owner should have a six (6) month period of operation to find any proven defective part in his engine or Rotax assembly.
2. There is, however, a one (1) year limit which starts on our invoice date to you. If we sold you an engine today, unless we hear from your, the warranty will end one year from today's date regardless of whether the engine was delivered to a customer of yours or not.

EXAMPLE A: We invoice an engine to you today and two (2) weeks later the engine is sold to your customer and put into service. Six (6) months from date of sale to customer the warranty period is finished. (The customer has owned the engine for six (6) months.)

EXAMPLE B: Engine is invoiced to you today but not put into service (not sold by you) for 3, 4, 5, or up to 6 months later. Your customer still has 6 months warranty as it still falls in the one period to you.

EXAMPLE C: Engine is invoiced to you today, but for some legitimate reason, either at your end or at your customer's end, the engine cannot be put into service until 7 months or up to a maximum of the 12 months after the invoice date to you. Then, before the 12 months from invoice date to you are up, you advise us the engine still has not been used and ask us for a one time, 6 month extension together with a valid reason.<sup>1</sup> We ask permission from Rotax for a 6 month extension of that particular engine. To this date, we have not been refused a **legitimate** request for extension. In this case, warranty period will elapse 18 months from our invoice date to you.

3. As you can see, it is important to properly rotate your engine stock. Never send out a newly arrived engine if you still have older engines in house.

## FAA PROCEDURES

--Obtaining an "N" Number

--Registration

--Obtaining An Airworthiness Certificate

### OBTAINING AN "N" NUMBER

In order to register your plane, it will be necessary to obtain an identification number for the plane. This is referred to as an "N" number.

If any number is acceptable to you, write to the FAA Aircraft Registry, Dept. of Transportation, P.O. Box 25504, Oklahoma City, OK 73125 and ask them to assign you a free U.S. identification number of their choice.

If you prefer a number of your own choosing or a smaller number, you may be able to obtain the exact number you want by asking the FAA registry to assign you a specific number of your choice.

**NOTE:** U.S. identification numbers do not exceed 5 symbols in addition to the prefix "N". These symbols may be all numbers (N55555), one to four numbers and a suffix letter (N5555A or N5A), or one to three numbers and two suffix letters (N555AB).

If you request a special "N" number it would be best to list at least five choices in case your first choice is not available. A special number of your own choosing will cost \$10.00 and you should enclose that fee with your letter.

### When To Obtain Your "N" Number

If you plan to complete your kit within a very short time, it is recommended that you obtain your "N" number right away. If your project will be fairly lengthy, you will not need to obtain your number until the last several months of construction. Keep in mind that if you request a special "N" number it can be reserved for no longer than one year. If this number has not been affixed to the fuselage within this time and the registration completed, it will be necessary to pay an additional \$10.00 to reserve that number for another year.

### AFFIDAVIT OF OWNERSHIP FORM

Enclosed you will find an Affidavit of Ownership Form. This form should accompany your letter requesting the assignment of an "N" number.

This form must be notarized as it establishes your ownership to the airplane even though you know you did build it. It will be used by the FAA to create a file on your aircraft and will serve as a legal document and a substitute for the Bill of Sale (AC Form 8050-2) that a buyer gets when he buys any existing airplane.

## REGISTERING YOUR AIRCRAFT

After you have written the Aircraft Registry requesting an "N" number, you will receive a form letter giving your number assignment. You will also receive a blank Aircraft Registration Form. (Sample Enclosed.) Complete the Application for Aircraft Registration (Form 8050-1) and return it to the Aircraft Registry along with the \$5.00 registration fee.

Retain the **PINK** copy of the Registration and mail both the **WHITE** original and the **GREEN** copy. Your **PINK** copy is your authority to operate the aircraft, when carried in the aircraft with an appropriate and current airworthiness certificate.

## RECEIVING AUTHORITY TO FLY YOUR AIRCRAFT

Registration alone does not authorize you to fly your aircraft. The aircraft must, after it has been properly registered, also obtain an Airworthiness Inspection by an inspector of the FAA, at which time the necessary Airworthiness Certificate may be issued. Then, and only then, is your aircraft ready for flight.

## WHAT IS THE PROCEDURE FOR OBTAINING AN AIRWORTHINESS CERTIFICATE

Since the final step in obtaining an Airworthiness Certificate is to obtain an inspection of your airplane by an official of the FAA, it is a good idea to make an early contact with the FAA inspector's office nearest your home. Members of the local EAA chapter or a local flying service may be able to help direct you to this office. The purpose of such an early contact would be to discuss with the FAA representative, your proposed home built project and to generally familiarize yourself with the procedures established by the FAA for home built projects. At this time you can establish a tentative plan for inspection of the aircraft upon completion. The typical FAA inspector is interested in your project and wants to help you do a good job.

The FAA requires that everyone building an airplane must maintain a construction log of the work he does on his airplane. You can use a notebook of conventional size and keep a daily diary of the work done on your aircraft. Since all our planes come with assembly manuals, it is a good idea to also make notes in the manual as well as listing dates when certain procedures were done. It is a very good idea to take photographs of work on your plane in various stages. This helps to document that you, the builder, actually completed 51% of this kit. (Advisory Circular 20-27C available from the FAA or EAA describes the procedure used so that your logbook will be a verification of having complete at least 51% of the aircraft yourself.)

## MY AIRCRAFT IS COMPLETED, ALL MARKING AND PLACARDS ARE IN PLACE. WHAT ELSE MUST I DO TO MY AIRCRAFT BEFORE I AM READY FOR MY PRE-CERTIFICATION INSPECTION?

Included in your manual is a weight and balance sheet. This will need to be completed before the inspection.

You will need to purchase a logbook for the aircraft, engine and propeller. These can be separate books or just one.

Have handy a copy of your Sales Invoice from us.

## I FEEL I AM READY FOR INSPECTION BY THE FAA INSPECTOR, WHAT DO I DO?

If you have had prior contact with your FAA inspector, you will probably be familiar with the procedures used by that office. Different offices have slightly different procedures. Some inspectors will help you fill out the paperwork at the time of inspection. Others require that you submit the paperwork prior to inspection. If you are not sure and there are no other builders in your area to ask, you could call and ask the local office. Or you can submit the following to the Inspector's Office.

1. A letter requesting a final inspection.
2. Form 8130-12 Eligibility Statement (sample follows).
3. Form 8130-6 Application for Airworthiness Certificate (sample follows).
4. A 3-view drawing of the aircraft or photos of topside and front view. Include with this the following:

Horsepower rating of engine and type of prop.

Empty weight and maximum weight at which the aircraft will be operated.

Number of seats and their arrangement (tandem, side by side).

Whether single or dual controlled.

Fuel capacity.

Maximum speed at which you expect to operate the aircraft.

5. Estimated time or number of flights required. (Usually 25 hours for aircraft equipped with certified aircraft engine and prop combinations and 40 hours for those with non-aircraft engine propeller combinations.)
6. The area over which you will be testing. (Request an area encompassing a 25 mile radius for day VFR operations. Exclude congested areas and airways, but try to include nearby airports even if a few miles beyond the 25 mile radius.)

Upon satisfactory completion of the necessary final FAA inspection of the aircraft and whatever ground tests may be required, the FAA Inspector will issue your amateur-built "Experimental" Airworthiness Certificate. Along with the certificate you will be given certain "**OPERATING LIMITATIONS**" under which you must operate the aircraft.

## WHAT ARE THE SPECIAL REQUIREMENTS FOR ATTACHING NUMBERS AND PLACARDS TO HOME BUILT AIRCRAFT?

### 10-1 DISPLAY OF MARKS

(Reference is FAR Part 45.23)

After you obtain the registration of your aircraft, the Registration numbers or marks must be affixed to the aircraft in some permanent fashion. The marks must be legible and have no ornamentation. They must contrast in color with the background.

The marks displayed on the aircraft shall include the letter "N" signifying U.S. Registry, followed by the registration number issued for the aircraft.

In addition, amateur-built(Experimental) aircraft must have displayed on that aircraft near each entrance to the cabin or cockpit, in letters not less than 2" not more than 6" in height, the word, "EXPERIMENTAL".

### 10-2 LOCATION OF MARKS ON FIXED WING AIRCRAFT (Reference is FAR Part 45.25)

(b) (1) If displayed on the vertical tail surfaces, horizontally on both surfaces, horizontally on both surfaces of a single vertical tail or on the outer surfaces of a multivertical tail. However, an aircraft on which marks at least 3" high may be displayed and in accordance with 45.29 (b)(1), the marks may be displayed vertically on the vertical tail surface.

(2) If displayed on the fuselage surfaces, horizontally on both sides of the fuselage between the trailing edge of the wing and the leading edge of the horizontal stabilizer. However, if engine pods or other appurtenances are located in this area and are an integral part of the fuselage side surfaces, the operator may place the marks on those pods or appurtenances.

### 10-3 SIZE OF MARKS

FAR 45.29 (b) (1) (iii) states "Marks at least 3" high may be displayed on an aircraft for which an experimental certificate has been issued under 21.191 (d) or 21.191 (g) for operating as an exhibition aircraft or as an amateur-built aircraft when the maximum cruising speed of the aircraft does not exceed 180 knots Calibrated Air Speed (CAS).

And (c) characters must be two-thirds as wide as they are high except "1" which must be one-sixth as wide as it is high and the letters "M" and "W" which may be as wide as they are high.

(d) Characters must be formed by solid lines one-sixth as thick as the character is high.

(e) Spacing. The space between each character may not be less than one-fourth of the character width.

### 10-5 IDENTIFICATION PLATE

(Reference is FAR Part 45.11)

In addition to affixing the aircraft's registration number to the sides of the fuselage, the builder must also identify his aircraft by attaching an identification plate to the aircraft's structure.

This identification data required to be inscribed on the plate for amateur-built aircraft shall include the following information:

- a. Builder's name and address
- b. Model designation
- c. Builder's serial number
- d. Date of manufacture

The identification plate containing these essential elements must be of fireproof material and must be secured in such a manner that it will not likely be defaced or removed during normal service, or lost or destroyed in an accident. It must be secured to the aircraft at an accessible location near an entrance, except that if it is legible to a person on the ground it may be located externally on the fuselage near the tail surfaces.

The identification plate information must be marked thereon by etching, stamping, engraving, or other acceptable fireproof marking.

Metal plates which comply with these requirements may be purchased from the Experimental Aircraft Association for a very nominal fee.

## AIRCRAFT INSTRUMENT MARKINGS & COCKPIT PLACARDS

Your reference is FAR Part 91.31 Civil Aircraft Operating Limitations and Marking Requirements

### 8-1 GENERAL

To insure that each person operating an aircraft does so within the operating limitations prescribed for it, the FAA requires that there is available in it a current Flight Manual, appropriate instrument marking and placards, or any combination thereof.

The purpose of the flight manual, markings and placards is to detail for the operator of the aircraft, the operational limitations prescribed for the aircraft.

In lieu of a flight manual, most amateur builders prefer to mark their instruments and to affix the necessary placards to the instrument panel as the primary means for complying with these requirements.

### 8-2 MARKINGS AND PLACARDS

The markings and placards necessary for the safe operation and handling of the aircraft should be displayed in a conspicuous place and may not be easily erased, disfigured or obscured. Such placards and markings should include but not necessarily be limited to the following criteria: Special emphasis on fuel system markings are very important; such as fuel valves-on-off fuel octane quantity, unusable fuel, minimum fuel for take-off, minimum fuel for inverted flight, etc.

### 8-3 POWERPLANT INSTRUMENT MARKINGS

Each required powerplant instrument should be marked to indicate the maximum and, if applicable, minimum safe operating limits with a **red radial line**.

Each normal operating range is to be marked with a **green arc** not extending beyond the maximum and minimum continuous safe operating limits.

Each engine speed range that is restricted because of excessive vibration should be marked with a **red arc**.

### 8-4 AIRSPEED INSTRUMENT MARKINGS

The airspeed indicator should be marked with a **red radial line** to establish the never-exceed speed. (Vne).

The takeoff and any pre-cautionary range should be marked with a **yellow arc**. The normal range is marked with a **green arc**. The flap actuation range is marked with a **white arc**.

### 8-5 AIRSPEED PLACARDS

There should be an airspeed placard in clear view of the pilot and as close as practicable to the airspeed indicator listing:

The design maneuvering speed.

The maximum landing gear operating speed (if applicable).

The maximum flap extension operating speed (if applicable).

## **8-6 LANDING GEARS**

If a retractable landing gear is used, an indicator should be marked so that the pilot can, at any time, ascertain that the wheels are secured in their extreme positions.

Each emergency control should be **red** and must be marked as to method of operation and identity.

## **8-7 CONTROL MARKINGS**

Each fuel tank selector should be marked to indicate the position corresponding to each tank and to existing cross feed position.

If safe operation requires the use of any tanks in a specific sequence, that sequence must be identified.

## **8-8 POWERPLANT FUEL CONTROLS**

Each fuel tank selector should be marked to indicate the position corresponding to each tank and to existing cross feed position.

If safe operating requires the use of any tanks in a specific sequence, that sequence must be identified.

## **8-9 FLIGHT MANEUVER PLACARD**

For non-acrobatic category airplanes, there should be a placard in front of and in clear view of the pilot stating: "No acrobatic maneuvers, including spins, approved."

For acrobatic category airplanes, there should be a placard in clear view of the pilot listing the approved acrobatic maneuvers and the recommended entry airspeed for each. If inverted flight maneuvers are not approved, the placard must have a notation to this effect.

## **8-10 BAGGAGE PLACARD**

The maximum baggage load permitted should be displayed in a conspicuous place adjacent to the baggage area.

## **8-11 PASSENGER WARNING PLACARD**

A placard must be affixed to the aircraft so that it is readily seen in the cockpit. It will state: "Passenger Warning-This aircraft is amateur built and does not comply with the Federal Safety Regulations for Standard Aircraft". This placard is part of a set available for EAA. See section 10-5.

## OPERATING LIMITATIONS

### 13-1 MANDATORY TEST FLIGHT PROVING PHASE

All amateur-built sport aircraft as well as standard aircraft have federally imposed operating limitations.

Upon satisfactory completion of the necessary final FAA Inspection of the aircraft and whatever ground tests may be required, the FAA inspector will issue your amateur-built "Experimental" Airworthiness Certificate.

He will also issue a form letter establishing the operating limitations applicable to your aircraft during its mandatory flight proving period. These Special Airworthiness Experimental Operating Limitations must be displayed in the aircraft at all times.

The operating limitations imposed on the aircraft during its flight proving period will be more stringent than those issued later after mandatory flight testing phase has been completed.

This phase may begin with the issuance of the aircraft's initial airworthiness certificate and the original operating limitations. At this time the FAA inspector will acquaint you with the requirements for a mandatory flight test and proving period. This flying will be confined to an assigned flight area approved by the FAA Inspector.

The presence of the FAA Inspector is not required, by regulation, at the initial flight of the experimental amateur-built aircraft. If time permits, however, it is not unusual for him to attend.

If he deems necessary, the inspector could issue a permit for a single flight within the boundaries of the airport and, upon witnessing the safe completion of the test, issue a further permit for more extended flights within the permissible area.

A tremendous responsibility for the safe operation of the experimental aircraft rests on the FAA Inspector. If the plane has any new and unusual features, he will naturally tend to treat its first flights with care. Also, pilot qualification and skill is a consideration.

### 13-2 PURPOSE OF THE FLIGHT TEST PERIOD

A flight test period is necessary to show to the FAA that the aircraft is controllable throughout its normal range of speeds and throughout all the maneuvers to be executed. It will also serve to prove that the aircraft has no hazardous operating characteristics or design features.

### 13-3 DURATION OF MANDATORY FLIGHT TEST PERIOD

For standard aircraft type engines: When an FAA approved aircraft engine/propeller combination is installed the flight test period is usually limited to 25 hours of flight time.

For non-aircraft type or automotive engines: An aircraft equipped with such an engine is required to be flown for a longer test period, usually at least 40 hours, to prove its reliability.

**NOTE:** It should be understood that the local FAA Inspector has the prime responsibility in determining the extent of the flight test period to be required for your aircraft. He is permitted to exercise considerable discretion in extending or in reducing the number of hours required to be flown during this period.



### 13-4 FLIGHT TEST AREA

The FAA Inspector will authorize the flight tests to be carried out in a designated and limited test area, usually within a 25 mile radius of the aircraft's base of operations.

He will insure the area selected is not over densely populated areas or in a congested airway.

In assigning the flight test area, the FAA Inspector may modify the size and shape of the area to suit the best purposes of the flight test program. In some locations, particularly around bigger cities where air traffic is heavy, a flight test area may not be practical. The builder must be prepared to except that an approved flight test area may not be the one chosen to him as the most convenient.

### 13-5 OTHER LIMITATIONS DURING THE FLIGHT TEST PERIOD

As a rule, the carrying of passengers or other crew members will not be permitted unless necessary to the safe operation of that aircraft.

### 13-6 AIRCRAFT FLIGHT LOG

During the flight test period, the pilot should record the aircraft flight history in an appropriate log book. This should be in addition to any engine tachourmeter or engine hourmeter that may be installed in the aircraft.

Specifically, the duration of each individual flight should be recorded including the number of landings made.

A full description of any mishaps, however minor, or any experiences not entirely normal that occur during the flight experience period should also be duly recorded.

Although not required, it is strongly recommended that all operating data be recorded flight by flight. Such information as airspeeds, cylinder head temperatures, etc., will be very valuable and may be used to determine or establish the various performance figures and operating characteristics of the aircraft.

Although the FAA Inspector is required by law to apply certain basic restrictions permanently to the amateur-built aircraft he is certificating, he can apply whatever other limitations he deems necessary at his own discretion. Unfortunately, nothing in the regulations states that the initial restrictions are required to be removed after successful completion of the test period....they only may be modified.

After the mandatory flight test period....then what?

## REPAIRMAN'S CERTIFICATION

The Repairman's Certificate is applied for using the application form 8610-2, available from the local FAA offices. You should ask for this when you apply for your final inspection on your aircraft. You should also be familiar with the Appendix D of FAR part 43. (Items included in the Annual Condition Inspection.)

The Repairman's Certificate is only available to those who have built 51% or more of the specific aircraft they are having inspected.

Every twelve calendar months a condition inspection is performed in accordance with Appendix D of FAR part 43. The repairman has to include the aircraft total time in service, the name, the signature and the certificate type number of the repairman or A & P, who does the examination.

A & P mechanics must do the Annual Condition Inspection for those who are non-builders who own an amateur-built aircraft. On those aircraft where the builder has a Repairman's Certificate, it is recommended that from time to time the Annual Condition Inspection of those aircraft be done by an A & P simply as a check on the builder/repairman's work. One legal representative recommends that every other Annual Condition Inspection for a builder holding a repairman's certificate be done by an A & P mechanic.

**FINAL INSPECTION**

Listed below are two checklists. One is a sample checklist for condition inspection from the FAA and the other is an EAA safety checklist. These should be very helpful in getting your airplane signed off by the FAA Inspector and ensuring that your airplane is safe for operation.

**APPENDIX 1. SAMPLE CHECKLIST FOR A CONDITION INSPECTION**

AC 90-89

**AIRCRAFT IDENTIFICATION:**

TYPE/SN \_\_\_\_\_

ENGINE MODEL/SN \_\_\_\_\_

"N" NUMBER \_\_\_\_\_

PROPELLER MODEL/SN \_\_\_\_\_

A/F TOTAL TIME \_\_\_\_\_

ENGINE TOTAL TIME \_\_\_\_\_

OWNER \_\_\_\_\_

PROPELLER TOTAL TIME \_\_\_\_\_

<b>GENERAL:</b>	<b>BUILDER</b>		<b>INSPECTOR</b>	
	Sat	Unsat	Sat	Unsat
REGISTRATION/AIRWORTHINESS/OPERATING LIMITATIONS				
AIRCRAFT IDENTIFICATION PLATES INSTALLED				
EXPERIMENTAL PLACARD INSTALLED				
WEIGHT AND BALANCE/EQUIPMENT LIST				
<b>WINGS:</b>				
REMOVE INSPECTION PLATES/FAIRINGS				
GENERAL INSPECTION OF THE EXTERIOR/INTERIOR WING				
FLIGHT CONTROLS BALANCE WEIGHT FOR SECURITY				
FLIGHT CONTROLS PROPER ATTACHMENT (NO SLOP)				
FLIGHT CONTROL HINGES/ROD END BEARINGS SERVICEABILITY				
FLIGHT CONTROLS PROPERLY RIGGED/PROPER TENSION				
INSPECT ALL CONTROL STOPS FOR SECURITY				
TRIM CONTROL PROPERLY RIGGED				
TRIM CONTROL SURFACES/HINGES/ROD END BEARINGS SERVICE				
FRAYED CABLES OR CRACKED/FROZEN PULLEYS				
SKIN PANELS DELAMINATE/VOIDS (COIN TEST)				

POPPED RIVETS/CRACKED/DEFORMED SKIN				
FABRIC/RIB STITCHING/TAPE CONDITION				
LUBRICATION				
WING ATTACH POINTS				
FLYING/LANDING WIRES/STRUTS FOR SECURITY				
CORROSION				
FLIGHT CONTROL PLACARDS				
INSPECT FIREWALL FOR DISTORTION AND CRACKS				
INSPECT RUDDER PEDALS AND BRAKES FOR OPERATION AND SECURITY				
INSPECT BEHIND FIREWALL FOR LOOSE WIRES AND CHAFFING LINES				
CHECK CONTROL STICK/YOKE FOR FREEDOM OF MOVEMENT				
CHECK FLAP CONTROL OPERATION				
CHECK CABLE AND PULLEYS FOR ATTACHMENT AND OPERATION				
PERFORM FLOODLIGHT CARBON MONOXIDE TEST				
ENSURE THE COCKPIT INSTRUMENTS ARE PROPERLY MARKED				
INSPECT INSTRUMENTS, LINES, FOR SECURITY CHECK/CLEAN/REPLACE INSTRUMENT FILTER				
INSPECT COCKPIT FRESH AIR VENTS/HEATER VENTS FOR OPERATION AND SECURITY				
INSPECT SEATS, SEATBELTS/SHOULDER HARNESS FOR SECURITY AND ATTACHMENT				
CORROSION				
<b>EMPENNAGE/CANARD:</b>				
REMOVE INSPECTION PLATES AND FAIRINGS				
INSPECT CANARD ATTACH POINTS FOR SECURITY				
INSPECT VERTICAL FIN ATTACH POINTS				
INSPECT ELEVATOR/STABILIZER ATTACH POINTS				
INSPECT HINGES/TRIM TABS/ROD ENDS FOR ATTACHMENT AND FREE PLAY (SLOP)				
INSPECT EMPENNAGE/CANARD SKIN FOR DAMAGE/CORROSION				
INSPECT ALL CONTROL CABLES, HINGES AND PULLEYS				
INSPECT ALL CONTROL STOPS				
<b>ENGINE:</b>				
PERFORM COMPRESSION TEST #1 _____ #2 _____ #3 _____ #4 _____ #5 _____ #6 _____				
CHANGE OIL AND FILTER (CHECK FOR METAL)				
INSPECT IGNITION HARNESS FOR CONDITION AND CONTINUITY				
CHECK IGNITION LEAD CIGARETTES FOR CONDITION/CRACKS				
CLEAN AND GAP SPARK PLUGS				

CHECK MAGNETO TIMING/POINTS/OIL SEAL/DISTRIBUTOR				
INSPECT ENGINE MOUNT/BUSHINGS				
CHECK LANDING LIGHT OPERATION				
CHECK POSITION LIGHTS OPERATION				
CHECK ANTI-COLLISION LIGHT FOR OPERATION				
INSPECT ALL ANTENNA MOUNTS AND WIRING FOR SECURITY				
CHECK ALL GROUNDING WIRES (ENGINE TO AIRFRAME, WING TO AILERON/FLAP, ETC)				
INSPECT RADIOS/LEADS/WIRES FOR ATTACHMENT & SECURITY				
INSPECT CIRCUIT BREAKERS/FUSES/PANEL FOR CONDITION				
<b>OPERATIONAL INSPECTION:</b>				
VISUAL INSPECTION OF THE ENGINE/PROPELLER				
ALL INSPECTION PANELS AND FAIRINGS SECURE				
PERSONNEL WITH FIRE BOTTLE STANDING BY				
BRAKE SYSTEM CHECK				
PROPER FUEL IN TANKS				
ENGINE START PROCEDURES				
OIL PRESSURE/OIL TEMPERATURE WITHIN LIMITS				
VACUUM GAUGE CHECK				
MAGNETO CHECK/HOT MAG CHECK				
IDLE RPM/MIXTURE CHECK				
STATIC RPM CHECK				
ELECTRICAL SYSTEM CHECK				
COOL DOWN PERIOD/ENGINE SHUT DOWN				
PERFORM OIL, HYDRAULIC, AND FUEL LEAK CHECK				
<b>PAPERWORK:</b>				
AIRWORTHINESS DIRECTIVES				
RECORD FINDINGS AND SIGN OFF INSPECTION AND MAINTENANCE IN LOGBOOKS				

**AFFIDAVIT OF OWNERSHIP FOR AMATEUR-BUILT AIRCRAFT**

U.S. Identification Number: N12344

Builder's Name: John Q. Amateur

Model: RANS S-9 Serial Number: 1288054

Class (airplane, rotorcraft, glider, etc.): Airplane

Type of Engine Installed (reciprocating, turbopropeller, etc.): Reciprocating

Number of Engines Installed: 1

Manufacturer, Model, and Serial Number of each Engine Installed: Rotax 503 3572333

Built for Land or Water Operation: Land

Number of Seats: 1

The above-described aircraft was built from parts by the undersigned and I am the owner.

\_\_\_\_\_  
(Signature of Owner-Builder)

State of: Kansas

County of: Anywhere

Subscribed and sworn to me before this \_\_\_\_\_ day of \_\_\_\_\_, 19\_\_\_\_\_.

My commission expires \_\_\_\_\_

\_\_\_\_\_  
(Signature of Notary Public)

**THIS PAGE IS ONLY A SAMPLE**

UNITED STATES OF AMERICA DEPARTMENT OF TRANSPORTATION FEDERAL AVIATION ADMINISTRATION- <b>MIKE MONRONEY</b> AERONAUTICAL CENTER AIRCRAFT REGISTRATION APPLICATION			CERT. ISSUE DATE
UNITED STATES REGISTRATION NUMBER <b>N 1234Y</b>			FOR FAA USE ONLY
AIRCRAFT MANUFACTURER & MODEL <b>RANS S-9</b>			
AIRCRAFT SERIAL No. <b>1288054</b>			
TYPE OF REGISTRATION (Check one box)			
<input checked="" type="checkbox"/> 1. Individual <input type="checkbox"/> 2. Partnership <input type="checkbox"/> 3. Corporation <input type="checkbox"/> 4. Co-owner <input type="checkbox"/> 5. Gov't. <input type="checkbox"/> 6. Non-Citizen Corporation			
NAME OF APPLICANT (Person(s) shown on evidence of ownership. If individual, give last name, first name, and middle initial.)  <p style="text-align:center;">John Q. Amateur</p>			
TELEPHONE NUMBER: ( <u>913</u> ) <u>888-8888</u>			
ADDRESS (Permanent mailing address for first applicant listed.)  Number and street: <u>#1 Build-it Road</u>			
Rural Route:		P.O. Box:	
CITY	STATE	ZIP CODE	
Anytown	KS	67601	
<input type="checkbox"/> <b>CHECK HERE IF YOU ARE ONLY REPORTING A CHANGE OF ADDRESS ATTENTION! Read the following statement before signing this application. This portion MUST be completed.</b>			
A false or dishonest answer to any question in this application may be grounds for punishment by fine and / or imprisonment (U.S. Code, Title 18, Sec. 1001).			
<b>CERTIFICATION</b>			
I/WE CERTIFY:			
(1) That the above aircraft is owned by the undersigned applicant, who is a citizen (including corporations) of the United States. (For voting trust, give name of trustee: _____), or: CHECK ONE AS APPROPRIATE:			
a. <input type="checkbox"/> A resident alien, with alien registration (Form 1-151 or Form 1-551) No. _____			
b. <input type="checkbox"/> A non-citizen corporation organized and doing business under the laws of (state) _____ and said aircraft is based and primarily used in the United States. Records or flight hours are available for inspection at _____			
(2) That the aircraft is not registered under the laws of any foreign country; and (3) That legal evidence of ownership is attached or has been filed with the Federal Aviation Administration.			
NOTE: If executed for co-ownership all applicants must sign. Use reverse side if necessary.			
TYPE OR PRINT NAME BELOW SIGNATURE			
EACH PART OF THIS APPLICATION MUST BE SIGNED IN INK.	SIGNATURE	TITLE	DATE
	John Q. Amateur	Builder/Owner	3/16/88
	SIGNATURE	TITLE	DATE
SIGNATURE	TITLE	DATE	DATE
NOTE Pending receipt of the Certificate of Aircraft Registration, the aircraft may be operated for a period not in excess of 90 days, during which time the PINK copy of this application must be carried in the aircraft.			

AC Form 8050-1 (12/90) (0052-00-628-9007) Supersedes Previous Edition

AC FORM 8050-1 IS A 3-PART FORM

THIS PAGE IS ONLY A SAMPLE



U.S. Department  
of Transportation  
Federal Aviation  
Administration

## ELIGIBILITY STATEMENT AMATEUR-BUILT AIRCRAFT

Instructions: Print or type all information except signature. Submit original to an authorized FAA representative. Applicant completes Section I thru III. Notary Public Completes Section IV.

### I. REGISTERED OWNER INFORMATION

Name(s) John Q. Amateur

Address(es) #1 Build-it Road Anytown KS 67601  
No. & Street City State Zip

Telephone No.(s) (913)888-8888 ( )  
Residence Business

### II. AIRCRAFT INFORMATION

Model RANS S-9 Engine(s) Make Rotax 503

Assigned Serial No. 1288054 Engine(s) Serial No.(s) 3572333

Registration No. N1234Y Prop./Rotor(s) Make Sterba

Aircraft Fabricated: Plan  Kit  Prop./Rotor(s) Serial No.(s) \_\_\_\_\_

### III. MAJOR PORTION ELIGIBILITY STATEMENT OF APPLICANT

I certify the aircraft identified in Section II above was fabricated and assembled by John Q. Amateur

Name of Person(s) (Please Print)

for my (their) education or recreation. I (we) have records to support this statement and will make them available to the FAA upon request.

#### — NOTICE —

Whoever in any matter within the jurisdiction of any department or agency of the United States knowingly and willfully falsifies, conceals or covers up by any trick, scheme, or device a material fact, or who makes any false, fictitious or fraudulent statements or representations, or makes or uses any false writing or document knowing the same to contain any false, fictitious or fraudulent statement or entry, shall be fined not more than \$10,000 or imprisoned not more than 5 years, or both (U.S. Code, Title 18, Sec. 1001.)

#### APPLICANT'S DECLARATION

I hereby certify that all statements and answers provided by me in this statement form are complete and true to the best of my knowledge, and I agree that they are to be considered part of the basis for issuance of any FAA certificate to me. I have also read and understand the Privacy Act statement that accompanies this form.

Signature of Applicant (In Ink)

John Q. Amateur

Date

3/16/88

### IV. NOTARIZATION STATEMENT

THIS MUST BE NOTARIZED!

**THIS PAGE IS ONLY A SAMPLE**





# APPLICATION FOR AIRWORTHINESS CERTIFICATE

**INSTRUCTIONS** — Print or type. Do not write in shaded areas, these are for FAA use only. Submit original only to an authorized FAA Representative. If additional space is required, use an attachment. For special flight permits complete Sections II and VI or VII as applicable.

I. AIRCRAFT DESCRIPTION

1. REGISTRATION MARK <b>N1234Y</b>	2. AIRCRAFT BUILDER'S NAME (Mark) <b>John Q. Amateur</b>	3. AIRCRAFT MODEL DESIGNATION <b>RANS S-9</b>	4. YR. MFR <b>88</b>	FAA CODING
5. AIRCRAFT SERIAL NO <b>1288054</b>	6. ENGINE BUILDER'S NAME (Mark) <b>Rotax</b>	7. ENGINE MODEL DESIGNATION <b>503</b>		
8. NUMBER OF ENGINES <b>1</b>	9. PROPELLER BUILDER'S NAME (Mark) <b>Sterba</b>	10. PROPELLER MODEL DESIGNATION <b>Wood 64 X 44</b>	11. AIRCRAFT IS (Check if applicable) <input type="checkbox"/> EXPORT <input type="checkbox"/> IMPORT	

II. CERTIFICATION REQUESTED

APPLICATION IS HEREBY MADE FOR: (Check applicable items)

A	1	STANDARD AIRWORTHINESS CERTIFICATE (Indicate category)	NORMAL	UTILITY	ACROBATIC	TRANSPORT	GLIDER	BALLOON	
B	X	SPECIAL AIRWORTHINESS CERTIFICATE (Check appropriate items)							
	2	LIMITED							
	5	PROVISIONAL (Indicate class)	1	CLASS I					
			2	CLASS II					
	3	RESTRICTED (Indicate operations to be conducted)	1	AGRICULTURE AND PEST CONTROL	2	AERIAL SURVEYING	3	AERIAL ADVERTISING	
			4	FOREST (Wildlife conservation)	5	PATROLLING	6	WEATHER CONTROL	
			7	CARRIAGE OF CARGO		0	OTHER (Specify)		
	4	EXPERIMENTAL (Indicate operations to be conducted)	1	RESEARCH AND DEVELOPMENT		2	X	AMATEUR BUILT	
			4	RACING		5	CREW TRAINING	3	EXHIBITION
			0	TO SHOW COMPLIANCE WITH FAR					
	8	SPECIAL FLIGHT PERMIT (Indicate operation to be conducted, then complete Section VI or VII as applicable on reverse side)	1	FERRY FLIGHT FOR REPAIRS, ALTERATIONS, MAINTENANCE OR STORAGE					
			2	EVACUATE FROM AREA OF IMPENDING DANGER					
			3	OPERATION IN EXCESS OF MAXIMUM CERTIFICATED TAKE-OFF WEIGHT					
			4	DELIVERING OR EXPORT	5	PRODUCTION FLIGHT TESTING			
			6	CUSTOMER DEMONSTRATION FLIGHTS					
C	6	MULTIPLE AIRWORTHINESS CERTIFICATE (Check ABOVE "Restricted Operation" and "Standard" or "Limited" as applicable)							

III. OWNER'S CERTIFICATION

A. REGISTERED OWNER (As shown on certificate of aircraft registration) IF DEALER, CHECK HERE →

NAME: **John Q. Amateur** ADDRESS: **#1 Build-it Road Anytown, KS 67601**

B. AIRCRAFT CERTIFICATION BASIS (Check applicable blocks and complete items as indicated)

AIRCRAFT SPECIFICATION OR TYPE CERTIFICATE DATA SHEET (Give No and Revision No.)	AIRWORTHINESS DIRECTIVES (Check if all applicable AD's compiled with and give latest AD No.)
AIRCRAFT LISTING (Give page number(s))	SUPPLEMENTAL TYPE CERTIFICATE (List number of each STC incorporated)

C. AIRCRAFT OPERATION AND MAINTENANCE RECORDS

CHECK IF RECORDS IN COMPLIANCE WITH FAR 91.173	TOTAL AIRFRAME HOURS	3 EXPERIMENTAL ONLY (Enter hours flown since last certificate issued or renewed) <b>0</b>
--	----------------------	---

D. CERTIFICATION — I hereby certify that I am the registered owner (or his agent) of the aircraft described above, that the aircraft is registered with the Federal Aviation Administration in accordance with Section 501 of the Federal Aviation Act of 1958, and applicable Federal Aviation Regulations, and that the aircraft has been inspected and is airworthy and eligible for the airworthiness certificate requested.

DATE OF APPLICATION: **3/16/88** NAME AND TITLE (Print or type): **John Q. Amateur** SIGNATURE: *John Q. Amateur*

IV. INSPECTION AGENCY VERIFICATION

A. THE AIRCRAFT DESCRIBED ABOVE HAS BEEN INSPECTED AND FOUND AIRWORTHY BY (Complete this section only if FAR 21.1B(3)d) applies:

2. FAR PART 121 OR 127 CERTIFICATE HOLDER (Give Certificate No.)	3. CERTIFICATED MECHANIC (Give Certificate No.)	6. CERTIFICATED REPAIR STATION (Give Certificate No.)
5. AIRCRAFT MANUFACTURER (Give name of firm)		
DATE	TITLE	SIGNATURE

V. ACTIVE REPLY CERTIFICATION

(Check ALL applicable blocks in items A and B)

A. I find that the aircraft described in Section I or VII meets requirements for:

4. THE CERTIFICATE REQUESTED	AMENDMENT OR MODIFICATION OF CURRENT AIRWORTHINESS CERTIFICATE
FAA INSPECTOR	FAA DESIGNEE
CERTIFICATE HOLDER UNDER	FAR 65 FAR 121 127 or 135 FAR 145

DATE: \_\_\_\_\_ DISTRICT OFFICE: \_\_\_\_\_ DESIGNEE'S SIGNATURE AND NO.: \_\_\_\_\_ FAA INSPECTOR'S SIGNATURE: \_\_\_\_\_

THIS PAGE IS ONLY A SAMPLE

# EAA Safety Check List

Spend some time with your plane and this check list before those first flights. Thirty minutes with a pencil here may be worth the rest of your life.

	Yes	No		Yes	No		Yes	No
<b>PROPELLER</b>			<b>ENGINE &amp; ENGINE COMPARTMENT</b>			<b>FUSELAGE-HULL</b>		
<b>1. Blades</b>			All stacks in good condition-no cracks or rusted-out areas?			All pulleys of proper diameter for bends, proper size for cable, and guarded?		
Laminations not separated?			Carb heat and cabin heat mufflers removed and manifold inspected?			All cable of proper size (1/8" min) and condition?		
Breaks, scratches, nicks tipping?			<b>5. Controls</b>			Any parts in system subject to rotation for any reason properly secured and safetied?		
Loose rivets in tipping?			All secured and safetied?			Return springs on rudder pedals?		
Drain holes in tip clear?			No excessive play in any linkages?			No interference between any control part (cable, tube or linkage) and any other part of the structure throughout full control movement?		
<b>2. Hub</b>			No interference between any control and the structure throughout the full operating range?			Adequate room for full control throw when aircraft is occupied?		
Any cracks or corrosion?			Carb heater gate open & close fully?			Controls arranged to minimize danger of blocking by foreign objects?		
Hub properly seated and safetied?			<b>6. Mount</b>			Grip properly secured to control stick or wheel?		
<b>3. Control Mechanism</b>			Secured and safetied?			<b>4. Electrical System</b>		
Oil leaks?			All joints inspected for cracks?			All grommets, particularly in firewall, snug fitting and in good condition?		
Worn bearings?			Any bends in mount tubes?			All wires of proper gauge, insulated, and secured?		
Secure?			Bushings in good condition?			Wires do not rest on abrasive surfaces?		
<b>4. Attachment</b>			<b>7. Cowlings</b>			Battery installation of sufficient strength?		
All bolt & nut threads undamaged?			Secured and/or safetied?			Battery properly ventilated and drained?		
All bolts & nuts secured & safetied?			All latches or fastenings working properly?			No corrosion at or around battery or its vents?		
<b>5. Spinner</b>			Any cracks properly checked or reinforced?			Fuses of adequate amperage?		
Cracks?			Cowlings clean?			<b>5. Fuel System-Tanks</b>		
Properly secured?			<b>8. Power Plant in General</b>			Drains properly located to discharge clear of aircraft?		
Is spinner chafing into prop?			All necessary safeties, palnuts, locknuts, etc. in place?			All outlets properly screened?		
<b>ENGINE &amp; ENGINE COMPARTMENT</b>			No fuel or oil leaks?			Breather inlets clear?		
<b>1. Fuel System</b>			All accessories secured & safetied?			Fuel shut-off valve installed?		
All lines of approved type?			<b>FUSELAGE-HULL</b>			Fuel shut-off valve easily reached by pilot?		
All strainers clean?			<b>1. Structure</b>			All fuel lines of proper approved type?		
All lines secured against vibration?			All welds sound?			All fuel lines secured against vibration?		
Gascolator bowl at low point in system when aircraft is in normal ground position?			All tubing straight and uncracked?			Is tank located so that sufficient head is available in maximum climb with minimum fuel? Placard if necessary?		
Fuel drains operative?			No rust or corrosion?			Has tank sufficient expansion area?		
All connections properly tightened?			All attach fittings sound, no cracks, elongation of holes or worn threads?			Any tank overflow discharge clear of hazardous areas on aircraft?		
<b>2. Oil System</b>			All rivets properly installed?			Is tank support sufficient to meet strength requirements?		
All lines secured against vibration?			Inspection openings for all vital areas?			Does tank clear surrounding structure?		
Oil tank has no cracks or leaks?			Fuselage properly drained, that is, no built-in moisture traps?			Do tank supports minimize strain and chafing?		
Tank properly secured & safetied?			Firewall of proper fireproof material?					
All plugs & strainers cleaned & safetied?			<b>2. Cover</b>					
<b>3. Ignition-Electrical System</b>			Properly attached?					
All wiring proper type and gauge?			No tears, distortions, or abrasions?					
All fastenings secured & safetied?			Any breaks or ruptures properly repaired?					
Magnetos properly grounded?			<b>3. Control System</b>					
Spark plugs cleaned & undamaged?			Properly secured and safetied?					
Spark plugs properly torqued?			Controls stops provided & adjusted?					
Engine grounded to airframe?			All fittings of proper thread & size?					
Starter/generator secured?								
<b>4. Exhaust Manifold</b>								
Secured and safetied?								
All gaskets in good condition?								

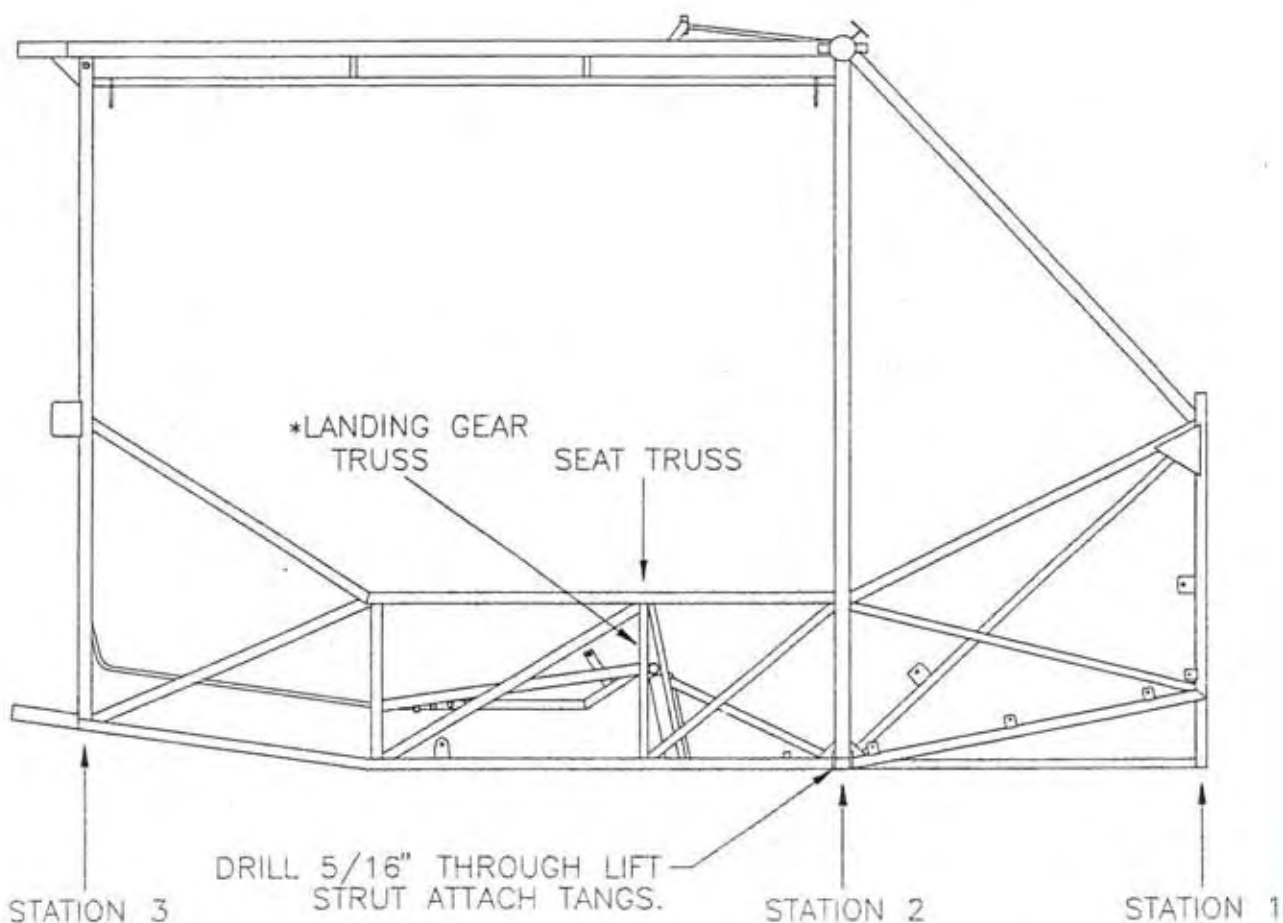
To insure its safe construction and operation, and to further emphasize the vital necessity for thorough consideration of every item which goes into your airplane, the following working check-list should be used, and it is suggested that it be made a part of the aircraft records.

	Yes	No		Yes	No		Yes	No
<b>EXITS</b>			<b>6. Heating-Ventilation</b>			Fuel overflow drains clear of aircraft - no tendency for overflow to soak into aircraft structure?		
1. Can aircraft be cleared rapidly in case of emergency?			Is cabin or cockpit in negative pressure area and liable to suck in exhaust fumes?			<b>LANDING GEAR</b>		
Are special precautions available during test period, such as jettisonable doors or canopy?			Is any provision made for ventilating cabin other than normal leakage?			Properly lubricated?		
If parachute is to worn, does it clear all controls?			<b>7. Windshield-Windows</b>			Proper oleo inflation?		
<b>Baggage Compartment</b>			Are windshield and windows of recognized aeronautical materials?			Shock cords or springs in good condition?		
1. Are walls and floors of sufficient strength to withstand flight loads?			Is windshield braced against positive or negative pressures in flight, either by design or extra bracing?			All attach fittings uncracked and sound?		
Can anything escape from baggage compartment by accident?			<b>WING-TAIL SURFACES</b>			All bolt holes not elongated?		
<b>Cabin-Cockpit</b>			<b>Fixed Surfaces</b>			All attach bolts secured and safetied?		
1. Instruments			Are all interior fastenings secured and/or safetied?			Brake lines in good condition?		
Are all instruments functioning and accurate?			Is interior properly weatherproofed?			Brakes operating properly?		
Are all instruments marked, max pressures, temperatures, speeds?			Have any mice been inside lately?			Correct hydraulic fluid in lines?		
Are all vital instruments easily visible to pilot?			<b>Movable Surfaces</b>			Wheels uncracked?		
2. Flight-Engine Controls			Are stops provided, either at wing or somewhere else in the control system?			Tires unworn & properly inflated?		
Are all engine controls marked or easily identifiable?			Are all hinges and brackets sound?			Excessive side play in wheel bearings?		
Are all engine controls smooth in operation without excessive resistance, and easily available to pilot?			Are all hinge pins secured and safetied?			<b>GENERAL</b>		
Are all flight controls arranged so that jamming by dropped gloves, etc. is impossible?			Is there any excessive play in hinges?			ALL BOLTS WHEREVER POSSIBLE, HEAD UP AND FORWARD.		
3. Fuel Systems			Is there any excessive play in control cables or tubes?			All exterior fastenings visible from cockpit or cabin should have safetied end toward pilot, wherever possible.		
Are all gas valves easily reached by pilot?			<b>External Bracing</b>			A complete walkaround inspection of the aircraft should be accomplished to check that every bolt visible on the exterior is secured and safetied. That there is no visible structural damage. That all inspection panels and covers are in place and attached. That all parts of the aircraft are in proper alignment.		
Are all gas valves marked ON, OFF, LEFT, RIGHT?			Is the interior of all struts weather protected?			DON'T FORGET TO PUT IN ENOUGH GAS PRIOR TO THAT FIRST FLIGHT - GROUND RUNNING AND TAXI TESTS CAN USE UP A LOT MORE THAN YOU THINK!		
Are all gas valves in such a position that accidental operation is impossible or guarded in such a way that accidental operation is impossible?			Are all adjustable fittings locked, secured, and safetied?			OK - Kick the tires, add another coat of paint and AWAY WE GO!		
4. Seats			Are struts undamaged by bends or dents?					
Are seats of sufficient strength for maximum flight loads contemplated?			Are all wires serviceable with proper end fittings?					
Does seat "flex" enough at any time to interfere with flight controls?			<b>Attach Fittings</b>					
5. Safety Belts and Shoulder Harness			Are bolts of proper size installed?					
Is installation and attachments of sufficient strength to meet 9G forward load minimum?			Are all bolts secured and safetied?					
Does attachment connect directly to primary structure?			Have all bolts been examined for wear?					
Are belts and harness in top condition?			<b>Flight Control Mechanism</b>					
Is belt of correct size, that is, no long over-tongue?			All cables and tubes unbroken or unbent & with proper end fittings?					
Is a separate belt and shoulder harness supplied for each occupant?			All control attachments secured and safetied?					
			All pulleys free from interference and guarded?					
			All torque tubes and bell cranks in good condition?					
			No interference with fuselage or wing structure throughout full control travel?					
			<b>Fuel Tanks</b>					
			(See Fuselage Section Also)					
			Are drains supplied at low point in tank when aircraft is in normal ground position?					

## S-6ES & S-6XL COYOTE II FUSELAGE ASSEMBLY

1. The fuselage comes pre-welded, painted and ready for assembly. Attaching nut plates to the various tabs is the only assembly required. The exact location of these nut plates will be called out where applicable.
2. Inspect the forward strut attach tangs at the lower S-2 location. See **Figure 01-02**. These should be drilled  $5/16"$ .
3. Before proceeding to the next section inspect the fuselage cage for damage.
4. The fuselage tailcone assembly will be completed after sub-assembly of the following sections.

**FIGURE 01-02**



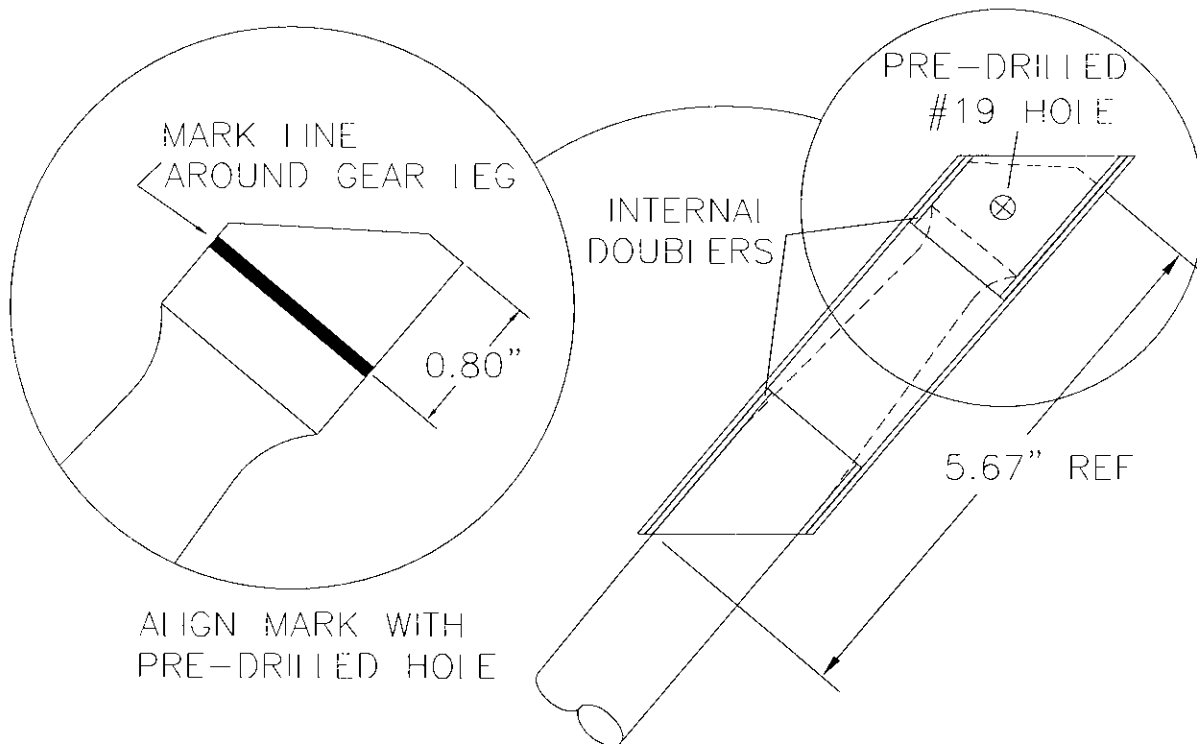
\* LANDING GEAR TRUSS LOCATION DEPENDS ON THE MODEL (TAILDRAGGER OR TRIKE)

**S-6ES COYOTE II****TRIKE - MAIN GEAR ASSEMBLY**

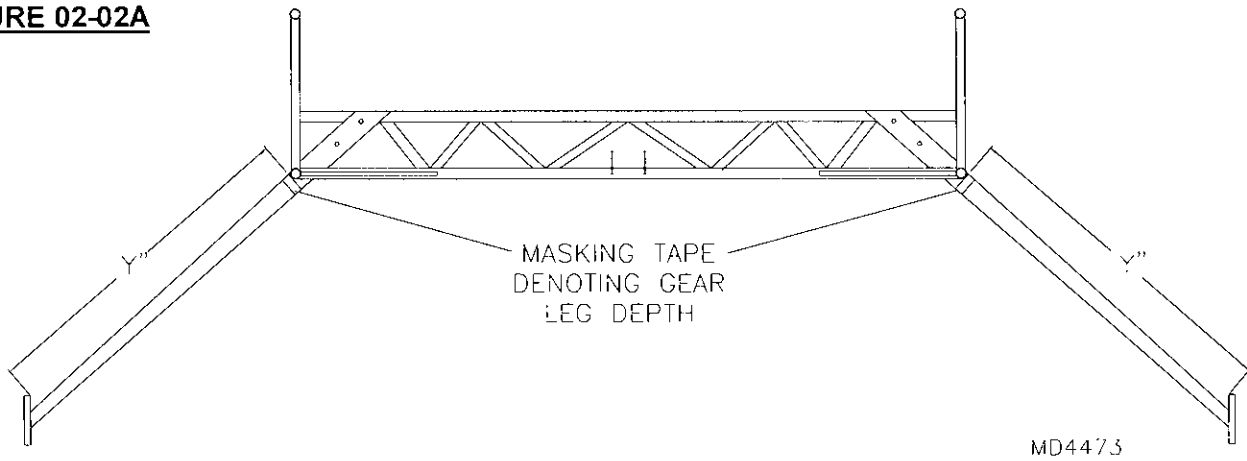
**NOTE:** Setting the toe-in on the main gear requires the nose wheel to be installed.

1. From the parts drawing and list collect the required components for the main gear assembly. It is easier to fit and drill the gear legs before the fuselage fabric covering is applied.
2. Place the fuselage on a set of sawhorses, or other suitable work surface. Mark a ring on the top of the gear leg per **FIGURE 02-02**. Install the gear legs with the fuselage in its upright position. Slide each gear leg into the sockets on the fuselage until the marked ring centers in the upper pre-drilled hole in the gear leg socket. See **FIGURE 02-02**. **IMPORTANT:** The gear legs must be centered on the marked hole in their socket. It may be necessary to slightly ream the inside of the socket to allow the gear leg to fully insert. It's also acceptable to lightly sand the upper portion of the gear leg (spinning the end of the gear leg over a disk sander works well). Both gear legs should measure equal length from a common point on the fuselage. See **FIGURE 02-02A**.

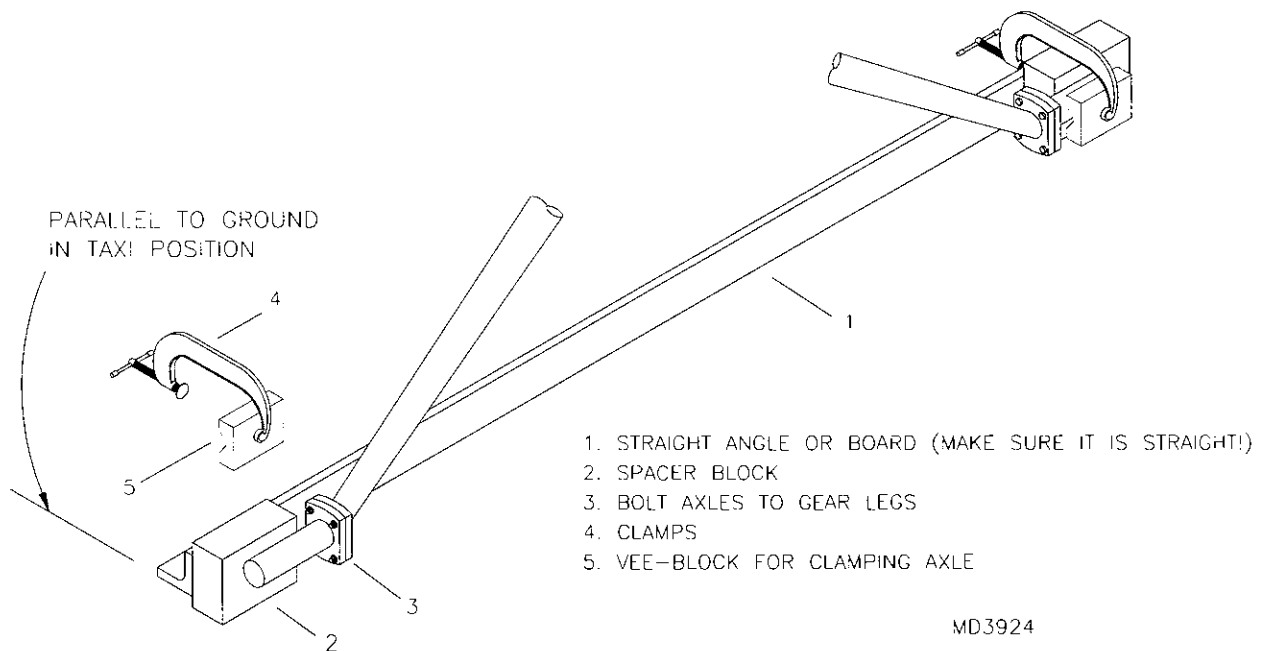
**FIGURE 02-02**



MD4914

**FIGURE 02-02A**

3. Assemble the axles to the gear leg assembly. With gear legs properly inserted, set axles straight by fabricating the alignment jig shown in **FIGURE 02-03**. **NOTE:** Aligning the gear legs requires the fuselage to be in the taxi position. **HINT:** Temporarily install the wheels and block the fuselage to the same height, then remove the wheels for setting the gear.

**FIGURE 02-05**

4. With the gear legs properly set, use the upper pre-drilled hole in the fuselage socket as a drill guide. Drill #19 from the front side to mark each gear leg. **IMPORTANT:** Do **NOT** drill through. A 90° drill attachment may be helpful.
5. Remove the gear leg, drill #19 in a drill press with a V-Block. **NOTE:** Use a slow speed and plenty of cutting fluid to keep the metal cool. Drill #11 in the drill press.
6. Re-insert the gear leg into the fuselage socket and align the holes. **HINT:** Re-lock in place with the alignment jig. Transfer drill #11 completely through the gear leg socket and gear leg.
7. Transfer drill with the supplied 6.2 mm drill bit.
8. Ream with the supplied 0.249" ream. **IMPORTANT:** Run the ream from front to back. It is recommended to run the ream completely through. Do **NOT** pull the ream back forward.
9. The gear legs are final installed after the fuselage is covered and clear-coated.
10. Install the gear legs using the hardware called out in the parts drawing. The wheel axles should be 90° to the aircraft centerline. If not it is possible to shim between axle and gear leg plate to correct alignment.
11. Camber (the leaning of the top of the tire) can also be adjusted by inserting a couple washers between the top of the axle and gear leg plate.
12. Bolt caliper mount, fairing mount bracket and axle to the gear leg assembly as per parts drawing. Assemble the wheel and brake kit as per parts manual and manufacturer's instructions. With the aircraft in a level attitude the brake assembly will be orientated to the aft and slightly downward. **CAUTION:** Be sure to safety wire the bolts holding the brake disk. The tire pressure should be approximate 25 psi. To install the wheel assembly, the outer brake pad removes via the 1/4" retainer bolts. Loctite and safety wire these bolts in final assembly.
13. Clean and pack the tapered wheel bearings. The tapered roller bearings are oiled from the factory for rust prevention, but not greased. The roller bearings should be cleaned, dried and then packed with suitable grease. Packing grease without first removing the oil will dilute the wheel grease, causing it to run out past the seal and not lubricate properly.
14. Slip the bearings and wheel / tire assembly back onto the axle. Install the castle nut and washer. Tighten the castle nut to manufactures specifications or bearing failure may result. Secure with the large cotter pin. Wrap Teflon tape on the threads of the brake fitting and install the fitting into the caliper. The fitting should face forward. At this point it is suggested to test fit the gear leg fairings so that they are ready for paint.

**IMPORTANT INFORMATION:** MATCO mfg wheels using tapered roller bearings are equipped with Timken bearings utilizing integrated grease seals on the bearing cone to ensure the longest possible life. The torquing procedure for bearings with these type seals is different than for tapered roller bearings without them. A common torquing technique for bearings *without integrated seals* is to tighten the axle nut until the wheel stops spinning freely and then back off to the nearest locking feature. **THIS TECHNIQUE WILL NOT WORK ON A BEARING WITH AN INTEGRATED SEAL.** The reason for a different torquing technique is that the grease seal produces some drag and makes the wheel feel somewhat stiff when rotated. Reducing the axle nut torque until the wheel spins freely will allow the grease seal and the bearing cone to improperly rotate with the wheel (the cone must not rotate relative to the axle). The higher rolling drag is completely normal for this bearing and allows for longer bearing life since the seal will keep most contaminants out. Timken specification state, for example, that the two 1.25 inch tapered roller bearing used on the WE51 will produce 18-26 inch pounds of torque (drag) when properly installed. A light coating of grease on the seal will help reduce the drag on initial installation. The drag will also reduce after the bearings have been installed and the seal relaxes in the bore. It

is important that the axle nut torque be sufficient to keep the seal from rotating with the wheel. With the bearings cleaned, dried, greased, and inserted in the wheel, the axle nut should be tightened until all play is out of the assembly. Rotate the wheel back and forth while tightening the nut to help seat the bearings. When all play is out of the assembly, and the wheel rotates freely, tighten to the next castle slot and insert the cotter pin. The rubber seal on the tapered roller bearing will remain stationary while the wheel rotates around it. If the seal is spinning on the axle, the nut should be tightened further until the seal stops spinning with the wheel.



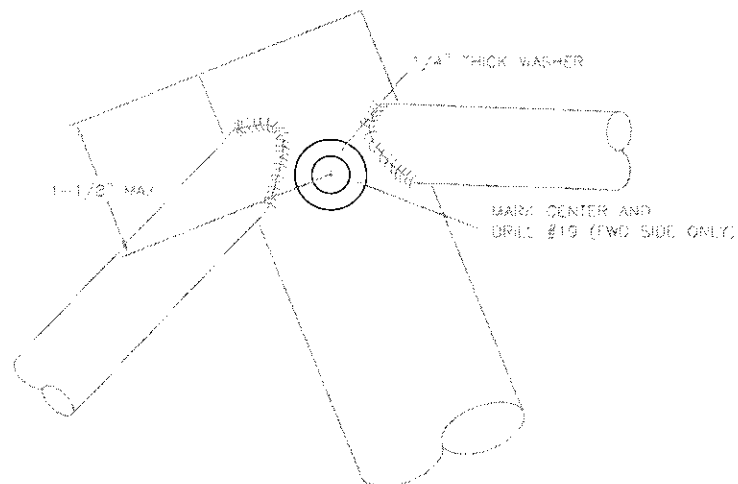
## S-6ES COYOTE II

### TAILDRAGGER - MAIN GEAR ASSEMBLY

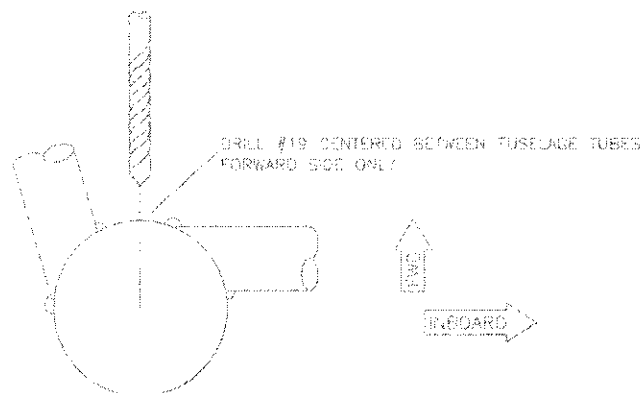
**NOTE:** Setting the toe-in on the main gear requires the tail wheel to be installed. Set the gear after the tail cone and tail wheel have been assembled.

1. From the parts drawing and list collect the required components for the main gear assembly. It is easier to fit and drill the gear legs before the fuselage fabric covering is applied.
2. Place the fuselage on a set of sawhorses, or other suitable work surface. Measure down on the forward side of each gear leg socket per **FIGURE 02A-02**. Mark and drill #19 through the forward side only. **IMPORTANT:** Make sure the bolt head and washer clears the welds. **HINT:** Lay a 1/4" Thick Washer between the welds and mark the center. Deburr inside of the socket.

**FIGURE 02A-02**



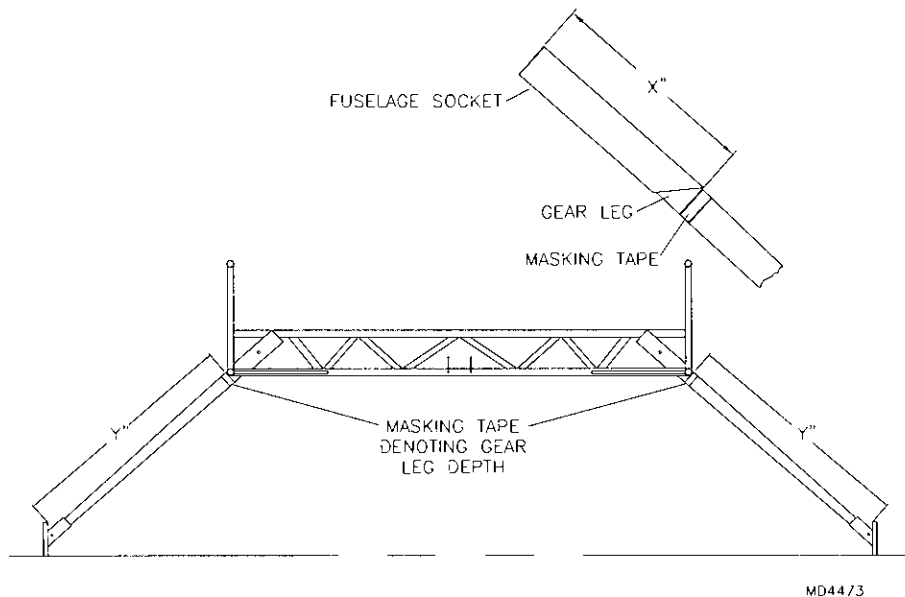
FWD SIDE OF GEAR SOCKET



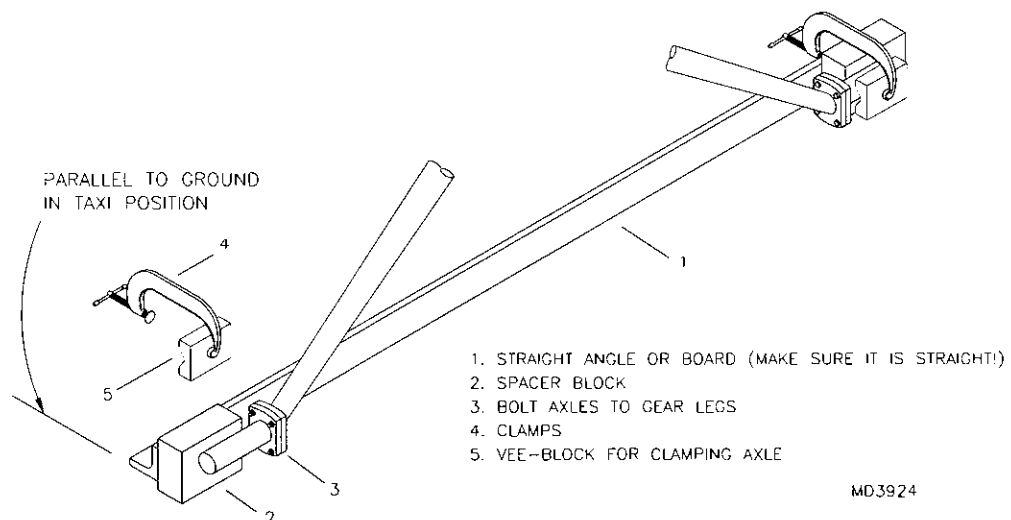
TOP VIEW OF GEAR LEG SOCKET

MD5215

3. Measure the depth of each gear leg socket in the fuselage. Transfer this measurement to the top of each gear leg and mark with a piece of masking tape. Install the gear legs with the fuselage in its upright position. Slide each gear leg into the sockets on the fuselage until the tape on the gear leg is flush with the socket. **IMPORTANT:** *The gear legs must be completely bottomed in their socket.* It may be necessary to slightly ream the inside of the socket to allow the gear leg to fully insert. It's also acceptable to lightly sand the upper portion of the gear leg (spinning the end of the gear leg over a disk sander works well). Both gear legs should measure equal length from a common point on the fuselage. See **FIGURE 02A-03**. If adjustments need to be made to gear leg length, remove material from the top of the longer gear leg.

**FIGURE 02A-03**

4. Assemble the axles to the gear leg assembly. With gear legs properly inserted, set axles straight by fabricating the alignment jig shown in **FIGURE 02A-04**. **NOTE:** *Aligning the gear legs requires the fuselage to be in the taxi position.* **HINT:** *Temporarily install the wheels and block the fuselage to the same height, then remove the wheels for setting the gear.*

**FIGURE 02A-04**

5. With the gear legs properly set, use the pre-drilled hole in the fuselage socket as a drill guide. Drill #11 from each side to mark each gear leg (Do **NOT** drill through). A 90° drill attachment will be required.
6. Remove the gear leg, drill #19 in a drill press with a V-Block. **NOTE:** Use a slow speed and plenty of cutting fluid to keep the metal cool. Drill #11 in the drill press.
7. Re-insert the gear leg into the fuselage socket and align the holes. **HINT:** Re-lock in place with the alignment jig. Transfer drill #11 completely through the gear leg socket and gear leg.
8. Transfer drill with the supplied 6.2 mm drill bit.
9. Ream with the supplied 0.249" ream. **IMPORTANT:** Run the ream from front to back. It is recommended to run the ream completely through. Do **NOT** pull the ream back forward.
10. The gear legs are final installed after the fuselage is covered and clear-coated.
11. Install the gear legs using the hardware called out in the parts drawing. The wheel axles should be 90° to the aircraft centerline. If not it is possible to shim between axle and gear leg plate to correct alignment.
12. Camber (the leaning of the top of the tire) can also be adjusted by inserting a couple washers between the top of the axle and gear leg plate.
13. Bolt caliper mount, fairing mount bracket and axle to the gear leg assembly as per parts drawing. Assemble the wheel and brake kit as per parts manual and manufacturer's instructions. With the aircraft in a level attitude the brake assembly will be orientated to the aft and slightly downward. **CAUTION:** Be sure to safety wire the bolts holding the brake disk. The tire pressure should be approximate 25 psi. To install wheel assembly, the outer brake pad removes via the 1/4" retainer bolts. Loctite and safety wire these bolts in final assembly.
14. Clean and pack the tapered wheel bearings. The tapered roller bearings are oiled from the factory for rust prevention, but not greased. The roller bearings should be cleaned, dried, and then packed with suitable grease. Packing grease without first removing the oil will dilute the wheel grease, causing it to run out past the seal and not lubricate properly.
15. Slip the bearings and wheel / tire assembly back onto the axle. Install the castle nut and washer. Tighten the castle nut to manufactures specifications or bearing failure may result. Secure with the large cotter pin. Wrap Teflon tape on the threads of the brake fitting and install the fitting into the caliper. The fitting should face forward. At this point it is suggested to test fit the gear leg fairings so that they are ready for paint.

**IMPORTANT INFORMATION:** MATCO mfg wheels using tapered roller bearings are equipped with Timken bearings utilizing integrated grease seals on the bearing cone to ensure the longest possible life. The torquing procedure for bearings with these type seals is different than for tapered roller bearings without them. A common torquing technique for bearings *without integrated seals* is to tighten the axle nut until the wheel stops spinning freely and then back off to the nearest locking feature. **THIS TECHNIQUE WILL NOT WORK ON A BEARING WITH AN INTEGRATED SEAL.** The reason for a different torquing technique is that the grease seal produces some drag and makes the wheel feel somewhat stiff when rotated. Reducing the axle nut torque until the wheel spins freely will allow the grease seal and the bearing cone to improperly rotate with the wheel (the cone must not rotate relative to the axle). The higher rolling drag is completely normal for this bearing and allows for longer bearing life since the seal will keep most contaminants out. Timken specification state, for example, that the two 1.25 inch tapered roller bearing used on the WE51 will produce 18-26 inch pounds of torque (drag) when properly installed. A light coating of grease on the seal will help reduce the drag on initial installation. The drag will also reduce after the bearings have been installed and the seal relaxes in the bore. It

is important that the axle nut torque be sufficient to keep the seal from rotating with the wheel. With the bearings cleaned, dried, greased, and inserted in the wheel, the axle nut should be tightened until all play is out of the assembly. Rotate the wheel back and forth while tightening the nut to help seat the bearings. When all play is out of the assembly, and the wheel rotates freely, tighten to the next castle slot and insert the cotter pin. The rubber seal on the tapered roller bearing will remain stationary while the wheel rotates around it. If the seal is spinning on the axle, the nut should be tightened further until the seal stops spinning with the wheel.

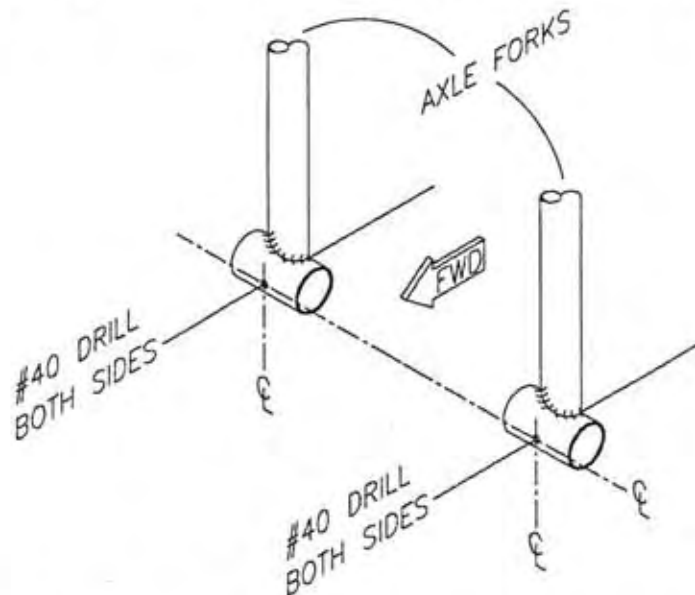
## S-6ES COYOTE II NOSE GEAR ASSEMBLY

**NOTE:** Keep the fuselage upside down for the nose gear assembly. If you have purchased the optional nose gear shimmy dampener, refer to that section during the installation of the nose gear.

1. Select all the parts for the nose gear except for the steering linkage. This will be assembled during the rudder pedal installation.
2. Apply a thin film of grease to the nose gear strut.
3. Lightly grease the thrust bearing and washer assembly and install on the nose gear strut. Slip the nose gear strut into the lower swivel bushing on the fuselage and install the stop ring and steering horn. Push the strut until it inserts into the top swivel bushing and bottoms out on the bearing assembly. Do not bolt the steer horn in place at this time. **NOTE:** Some filing or reaming of the fuselage bushings may be required to allow insertion and free rotation of the nose gear. However, it is important to not ream any more than necessary. Nose gear shimmy may result.
4. Locate the center of each axle bushing on the nose gear fork. Drill a #40 hole through the bushings on center line. See **FIGURE 03-04**.

Refer to the brake section and mount the tire onto the nose wheel. Install the wheel/tire assembly into the nose fork by first checking axle insertion into the hub bearings. If the axle will not slide into the wheel, spin sand it on a belt or disc sander. Install the axle with the aluminum bushings on each side. Note that the bushings may need to be filed to fit. Using a #40 drill bit, transfer drill through the pre drilled holes in the axle bushings on the fork through the axle and install the cotter pins to retain the axle.

**FIGURE 03-04**



MD2958

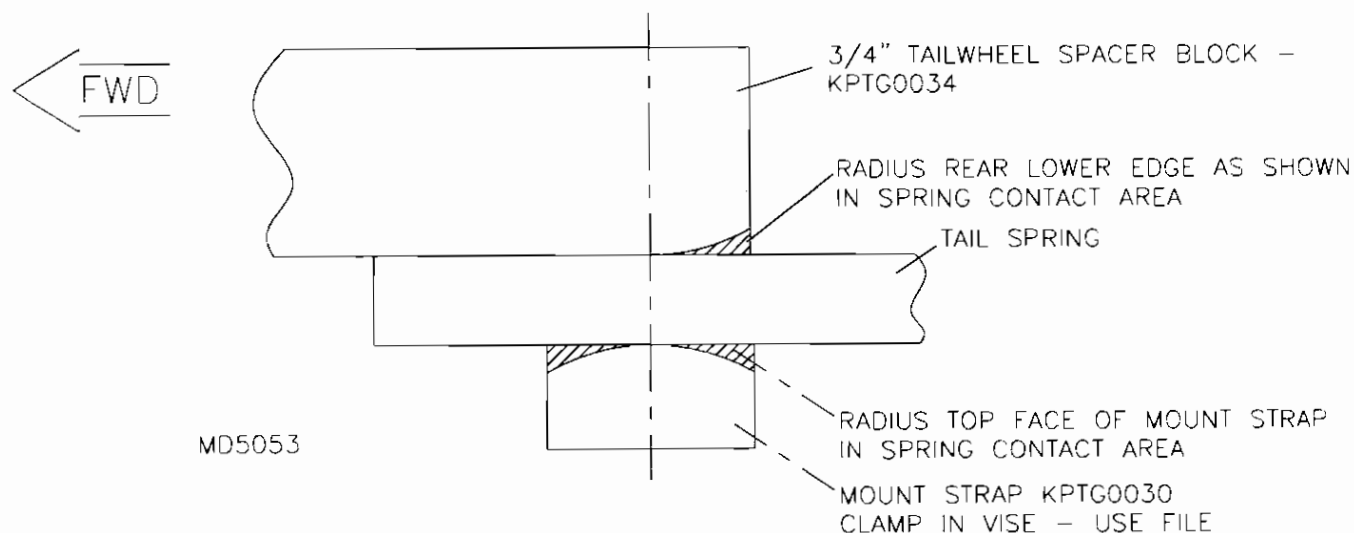
5. Turn the fuselage right side up. Push the strut so that the thrust bearing and washers are tight against the lower swivel bushing. Push down the stop ring and steer horn. View the top of the fork and steer horn from above. Line the tabs on the horn parallel with the fork and drill through from each side of the steer horn with a #11 drill bit and bolt in place.
6. While rotating the nose column, lube the swivel bushings with a quality grease. This will be required at least every 12 months under normal operations. Disassemble, clean and re-lube the spring every 12 months or as required. To service, weight tail and tie with the nose wheel off the ground. Remove, clean and re-assemble. Use weight of aircraft to depress spring for bolt insertion. Inspect bolt every pre-flight for wear. Replace if the bolt shows signs of "grooving".

## S-6ES COYOTE II TAILWHEEL ASSEMBLY

**NOTE:** Tailwheel and Tail Spring assembly can only be done after Tailcone Assembly is completed.

1. Select the parts depicted in the parts drawing.
2. Modify the 3/4" Tailwheel Spacer Block and Tailwheel Mount Strap per **FIGURE 03A-02**. Bolt the Tail Spring to the Tail Spring Mount Plate with the 3/4" Spacer Block between.

**FIGURE 03A-02**

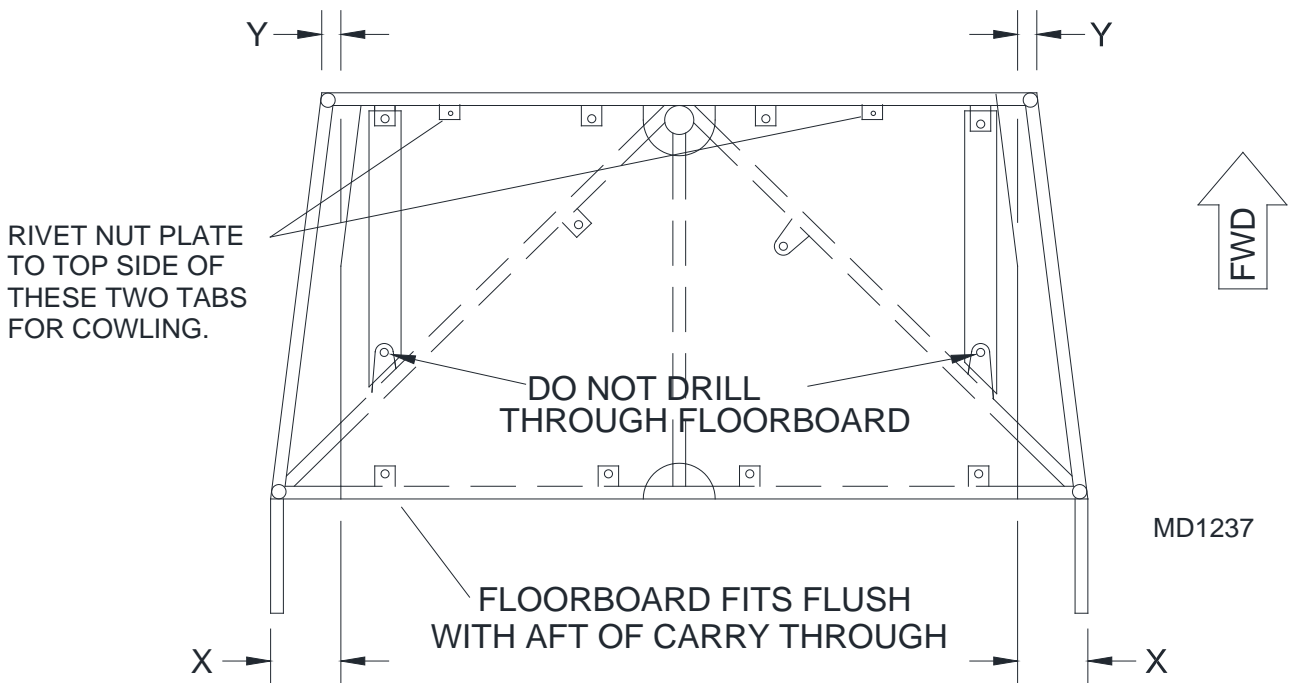


3. Bolt the Tail Spring Assembly to the tailcone. File or sand the Tailwheel Bushings to fit tight against the Tailwheel Spring. The Tail Cable Attach Hummertangs must also be tight. **CAUTION:** Do **NOT** remove too much material. The Tailspring must be tight and centered between the Bushings.
4. Bolt the Tailwheel to the Tail Spring assembly.
5. The S-6 tailwheel is full swivel. This allows pivot turns using brakes. A cam mechanism allows it to engage for steering. If the tailwheel mount leans to one side the full swivel feature will not work to that side. Shim the tailwheel to run vertical. Close study of the tailwheel cam will reveal its operation. If your tailwheel does not full swivel with side load or brake inputs try filing a radius on the corners of the cam parts.
6. Steering is provided through the two chains and springs. Spring tension should be tight with the springs compressed about half of the full amount. Loose steer springs will cause very soft, indefinite steering. The spring is retained to the horn using two of the "S" hooks. Squeeze shut the "S" hooks, but do not crush, this will allow full steering movement. For assembly details on the tailwheel rudder steer horn, see **Rudder Assembly**.
7. After the Tailwheel is assembled to the aircraft, check it for proper steerage and alignment. The steering springs should be connected with enough tension (about half compressed) to move the tailwheel after the rudder has moved 10 degrees side to side.

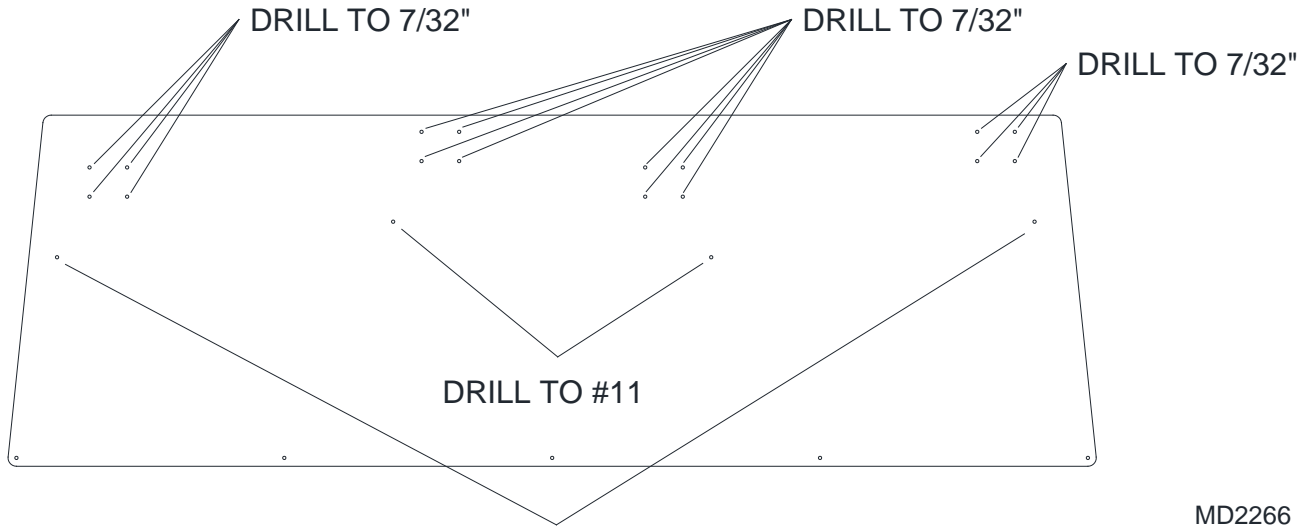
## **S-6ES COYOTE II - FLOORBOARD & RUDDER PEDAL INSTALLATION**

1. The floorboard comes pre-cut, finished and ready to position in place. Clamp the floorboard in position as shown in **Figure 04-01**. **HINT:** *Pull the nose gear out enough to slip the floorboard in from the front.* With the floorboard clamped in position, drill up from the bottom with a #11 drill bit using the four tabs on the S-1, four tabs on the S-2 and the two **FWD** tabs on the diagonal tubes as drill guides. **HINT:** *Use a wood block placed over the top to prevent splinters.*

**FIGURE 04-01**

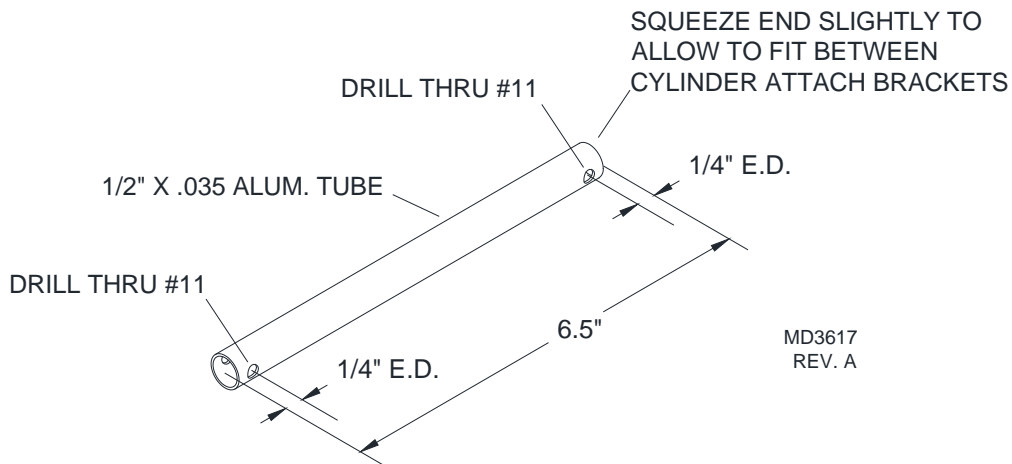


2. Remove the floorboard and position the floorboard support channels over the outboard tabs on the S-1 and AFT tabs on the diagonals. Trim the AFT edge of the channel to match the angle of the diagonals. Using the tabs as a drill guide, drill the channels #11. Drill #40 the forward end of the channels through the nut plate mount holes on the S-1 tabs. Remove and debur channels. Rivet the channels in place. Install nut plates on the perimeter tabs of the fuselage cage. Also install nut plates on the forward two diagonal tabs. Notice that the FWD tab on the right diagonal needs to be a single ear nut plate. Temporarily re-install the floorboard using the hardware shown.
3. Drill the wear plate as shown in **Figure 04-03**. Temporarily bolt the wear plate in place using the two center rudder pedal holes. Position rudder pedal tube assemblies parallel to each other and drill #11 the floorboard and support channel thru outer pivot. Using the sixteen holes for the brake mount brackets as guides, drill the floorboard 7/32".

**FIGURE 04-03****TRANSFER DRILL #11 FROM RUDDER PEDALS**

MD2266

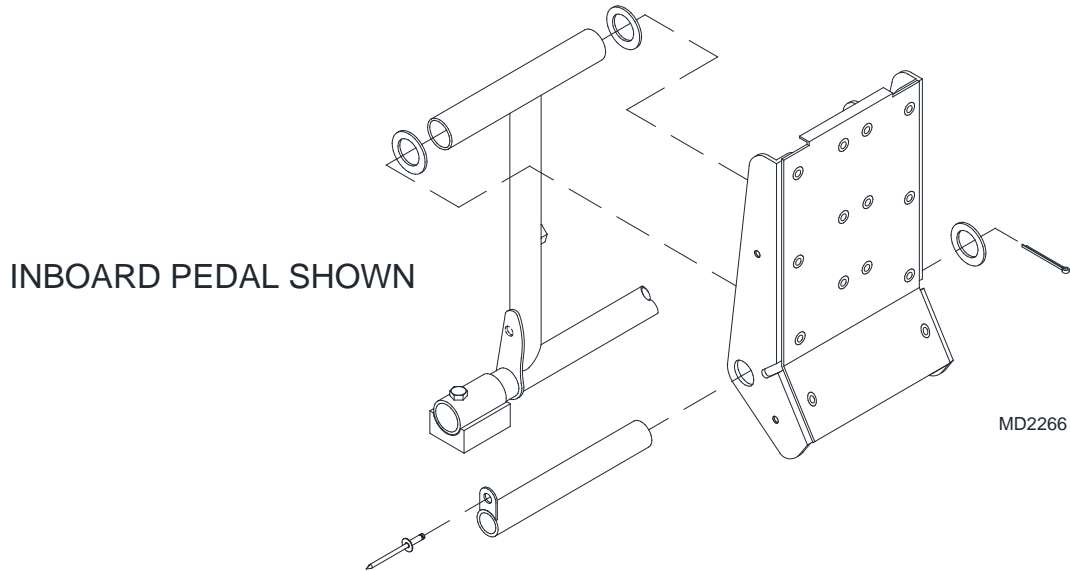
4. Remove the rudder pedals and floorboard. Install the tee nuts from the bottom of the floorboard. Install nut plates to the floorboard support channels. Re-install floorboard, wear plate, and rudder pedals. Install the brake mount brackets using the hardware shown. Be sure to orient the brackets correctly. The brake mount brackets face with the angled side forward. See the parts manual for exploded views.
5. Rivet together the upper toe pedal assembly as shown in the parts manual. Size drill #30 as required. Be sure to debur all holes before final assembly of the upper toe pedal. Install the lower end of the Hydraulic Cylinder into the brake mount brackets using the hardware shown. Attach the "U" bracket to the rudder pedal-cylinder attach brackets using the hardware shown.
6. **FOR SINGLE HYDRAULICS ONLY:** Fabricate and install the rudder pedal link rods on the passenger side. Refer to **Figure 04-06**. The link rods should match the length of the cylinders.

**FIGURE 04-06**MD3617  
REV. A

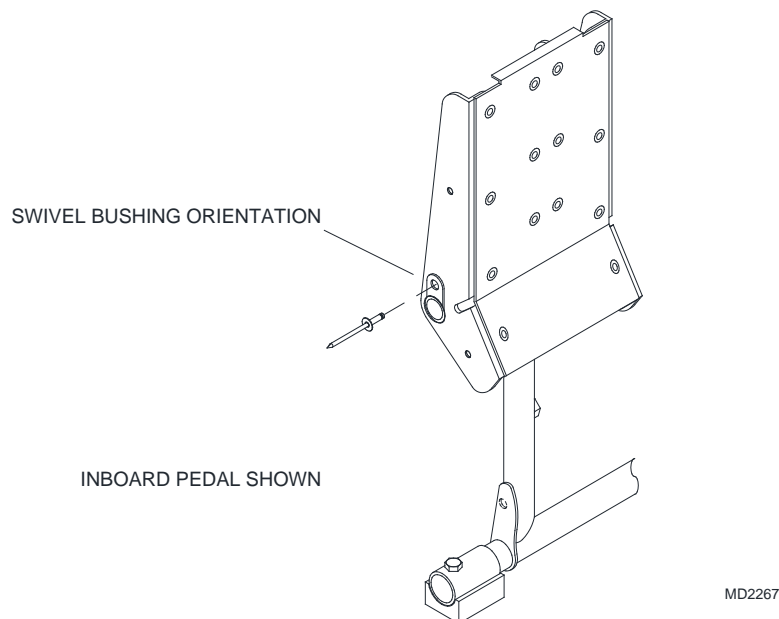


7. Install the toe pedal assembly to the rudder pedals by sliding the swivel bushings in place. See **Figure 04-07**. Be sure to include the 1/2" plastic washers between the rudder pedals and the toe pedal assembly. **NOTE:** *The outboard swivel bushings have an insert nut welded in. Drill the insert nut to #11. This is the location of the rudder cable attachment. Make sure these swivel bushings face the outside of the airframe on the outermost pedals.* **HINT:** *Install the 3/16" bolt into the outboard swivel bushings before assembly.* Line up the tangs on the end of each swivel bushing with the toe pedal assembly and drill the edge of the toe pedal to 3/16" using the swivel bushings as a guide. See **Figure 04-07A** and parts manual for orientation of the swivel bushings.

**FIGURE 04-07**



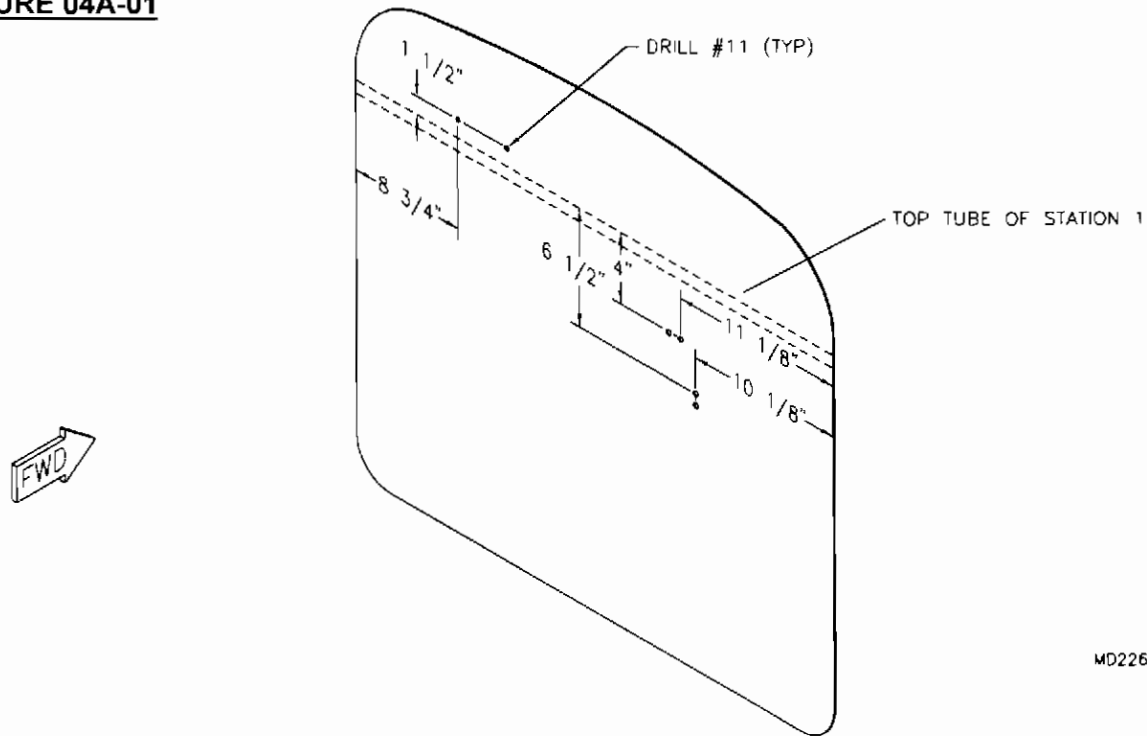
**FIGURE 04-07A**



## S-6ES COYOTE II - INSTALLATION OF HYDRAULIC ACCESSORIES

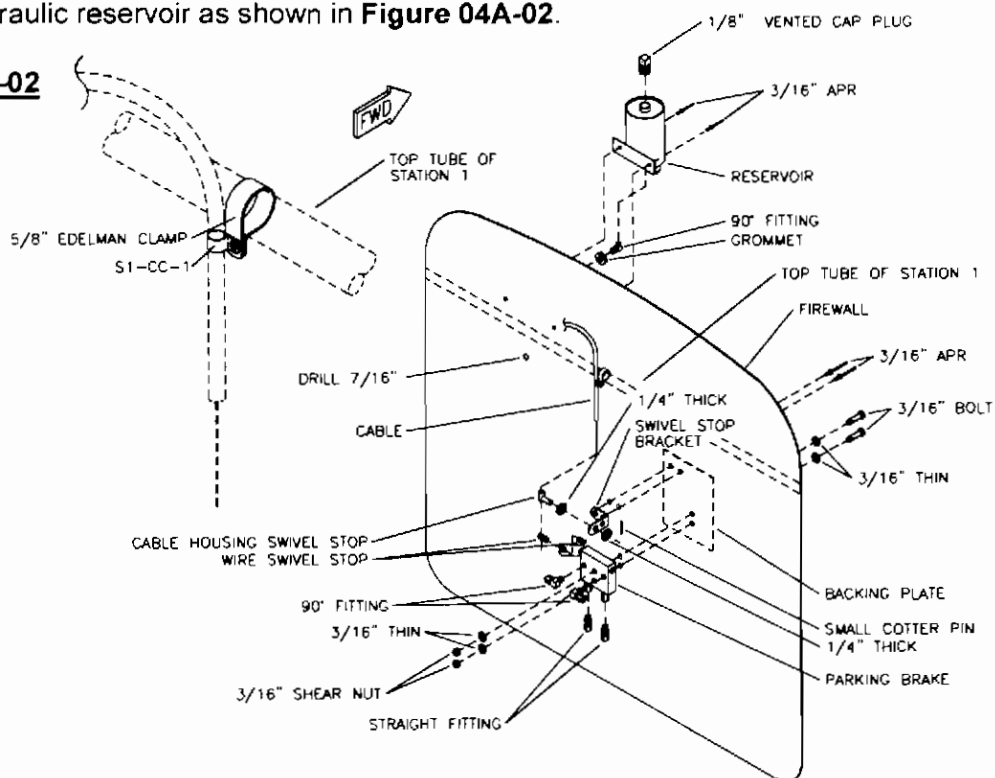
1. Installation of the firewall accessories should be performed when the firewall is test fit in **Section 6 - Firewall Assembly** of the manual. The locations of the accessory mounting holes are shown in **Figure 04A-01**. One hole location is given, use the parking brake, swivel stop bracket and reservoir to locate the second hole. Use the firewall as a guide to locate the required holes in the park brake backing plate. Rotate reservoir so the 90° fitting is aft. Locate a 7/16" hole for the brake line to pass thru the firewall. Insert the grommet to protect the line. Drill the hole in Parking Brake Valve arm to 1/4".

**FIGURE 04A-01**



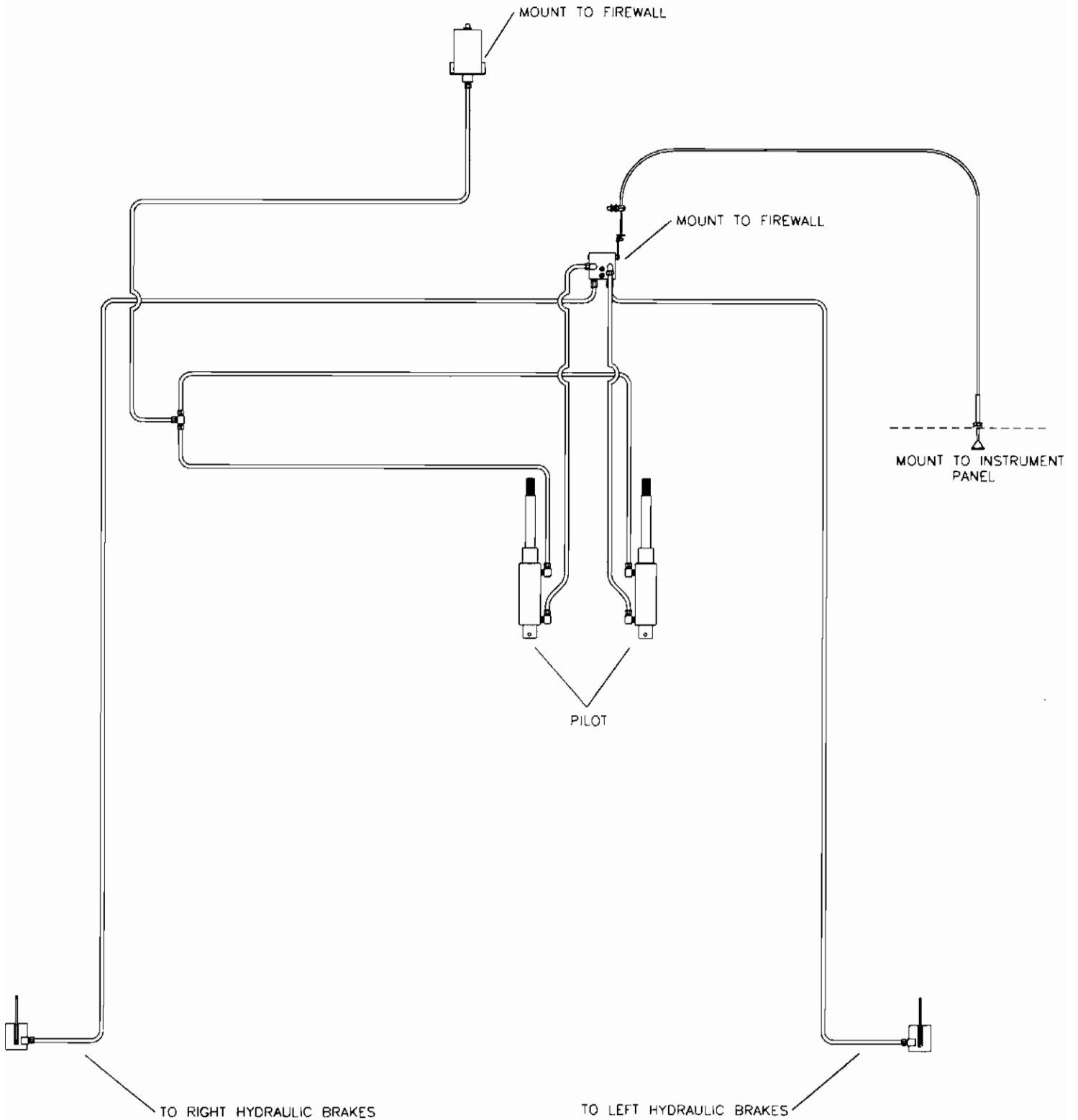
2. During final assembly install the parking brake, park brake backing plate, park brake control cable, and the hydraulic reservoir as shown in **Figure 04A-02**.

**FIGURE 04A-02**



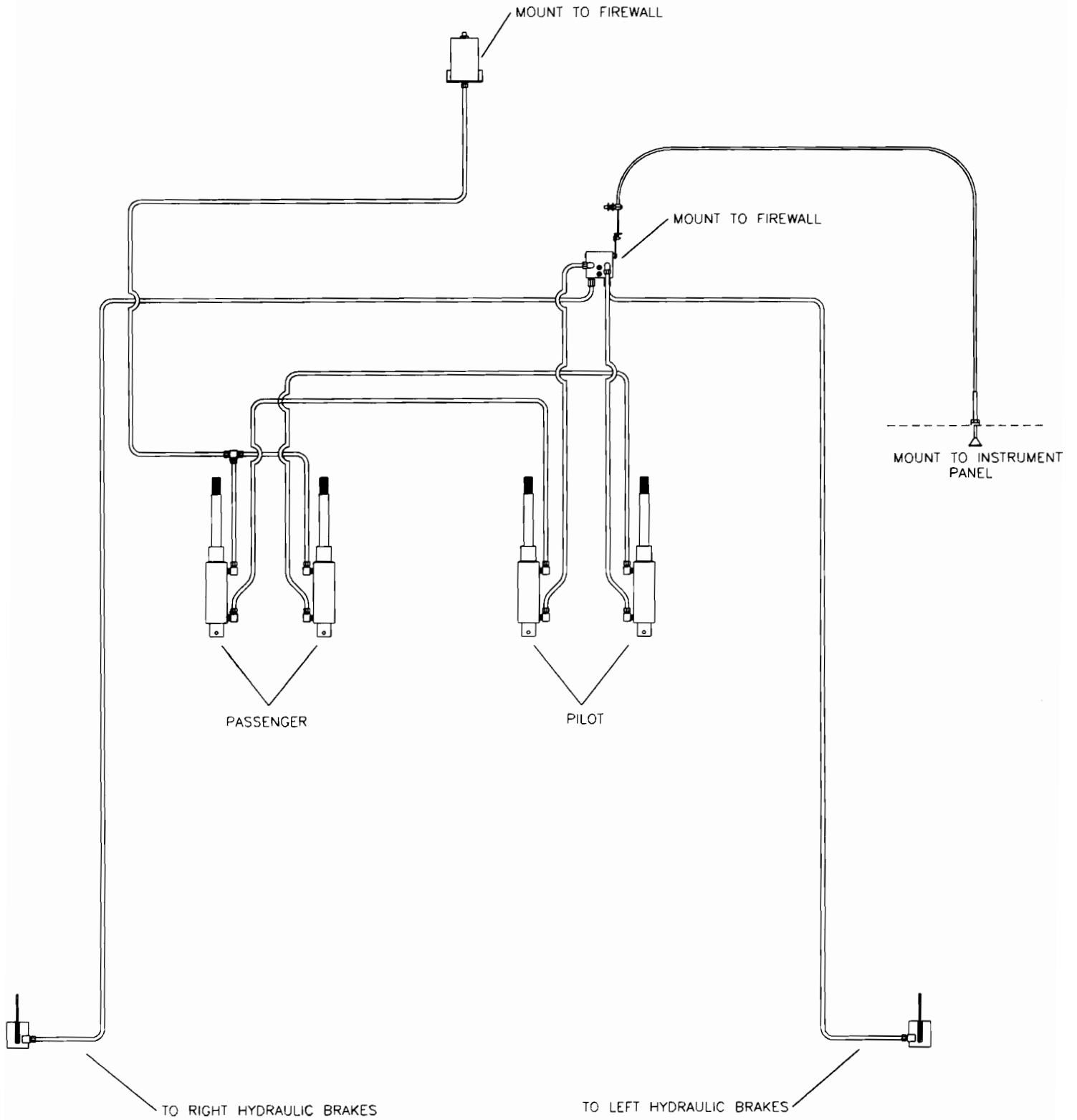
- 3. See **FIGURE 04A-03** for single hydraulic brake line routing. See **FIGURE 04A-03A** for dual hydraulic brake line routing.

**FIGURE 04A-03**



MD4474

**FIGURE 04A-03A**



## FILLING OF THE HYDRAULIC BRAKE SYSTEM

**NOTE:** These steps should be done during final assembly after floorboards, firewall, and instrument panel are installed. It may be necessary to move one of the bleed valves to the opposite side of the caliper assembly. Both bleed valves should be on the bottom side of the caliper. Wrap Teflon tape on the bleeder screw to minimize leakage during bleeding. **IMPORTANT:** Use only standard aircraft **MIL-H-5606 Red Hydraulic Fluid**. Improper brake fluid will ruin the brake system seals. **Never use Automotive Brake Fluid!**

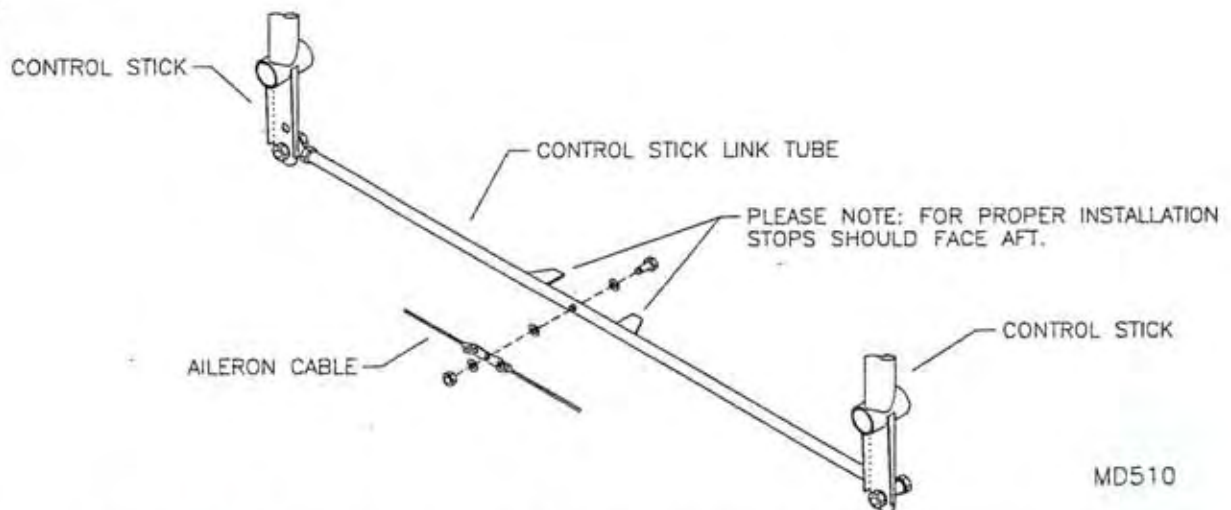
1. Open the lower left bleed valve. With the reservoir cap removed, start filling the system from the bottom. **NOTE:** A small hand held oil pumping can with a short piece of 1/8" ID clear hose (blue primer line works well) attached works well to fill the system. Fill the system until reaching just above the "T". Close the left bleed valve. Open the right bleed valve and fill the system until the air is removed from the right line. Close the right bleed valve.
2. Check your work by insuring that the reservoir has fluid and that you have a "hard pedal". If you have a "soft pedal", pump the brakes several times. Many times that will fix the problem. Bleed any accumulated air from the system. Tighten the bleeder valves and replace the rubber cap.
3. When satisfied fill the reservoir to approximately 3/4 full by pouring directly into the reservoir.
4. Test the brakes **THOROUGHLY** before flying. All air bubbles should be removed from the lines. Any size air bubble could cause insufficient braking. Please taxi test completely before flying.
5. The non-asbestos organic composition brake pads require a thin layer of glazed material at the lining friction surface in order to provide maximum braking performance. This glazed layer is produced by the heat generated during normal braking operations, and is maintained during the life of the lining. Since new brake pads do not have this layer, it must be created by the following process:
  - Heat the pads by performing a full stop from 30 mph. **CAUTION:** Only perform once comfortable with the aircraft.
  - Allow brakes to cool for 5-10 minutes.
  - Test the brakes at a high static rpm run-up. If the brakes hold, break-in is complete. If they fail to hold, repeat above steps until they do.

## S-6ES & S-6XL COYOTE II CONTROL STICK ASSEMBLY

The S-6ES and S-6XL features a cable and push pull tube operated aileron control system. To help with quick knock down of the wings telescoping sleeves are used to connect the aileron push pull tubes. These are retained by quick pins and require close inspection before each flight. Please be sure to inspect for correct insertion of these pins before each flight.

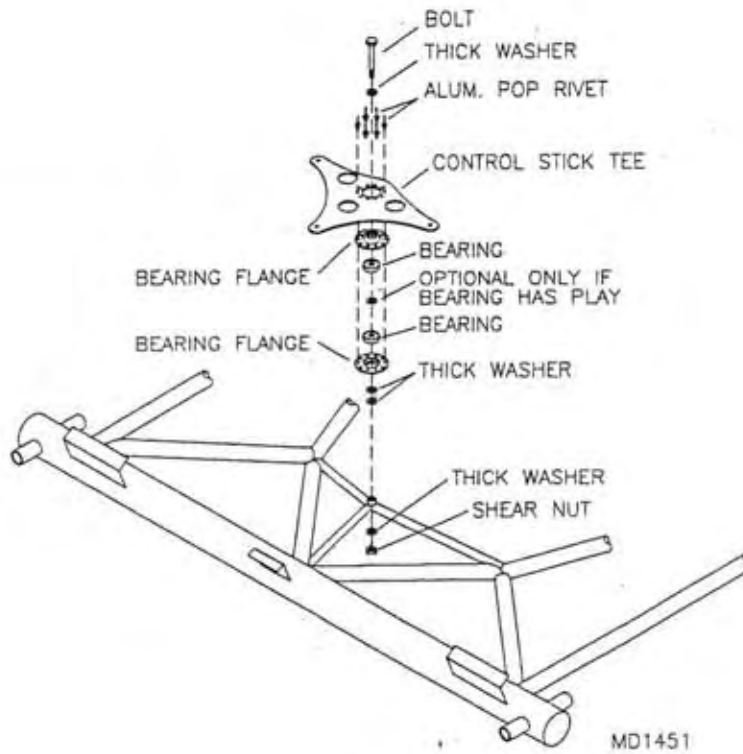
1. Refer to the parts catalog and select the required components for assembly.
2. Drill out ONE of the control stick's lower holes to 1/4" diameter. The other control stick has a 3/16" bolt inserted and does not need to be drilled.
3. Grease the inside of the connect tube pivot bushing, the bearings and the outside of the control stick torque tube's pivot stubs. Slip the control sticks onto the torque tube with the washers and bearings in the order shown in the parts drawing. Run on the 3/4" nut until it takes out all the play in the stick but is not too tight to cause binding.
4. Assemble the control stick link tube as per **Figure 05-04**. Assemble the unit to the control stick connector tubes. Adjust the sticks parallel using the rod end. The fixed end of the link tube uses a 1/4" diameter bushing slightly taller than the link tubes bushing to allow the bolt to be tightened and not bind the bushing. Fabricate the bushing using the 1/4" aluminum tube provided. For easy fabrication drill out the inside diameter to 3/16" before cutting to length. Measure the link tube bushing and add 1/32" for the inner bushing cut length. It should measure approximately 21/32". Apply grease to this bushing prior to assembly. The 3/16" bolt must be tight to hold the alignment to obtain proper cable clearance and the link tube must swivel freely.

**FIGURE 05-04**



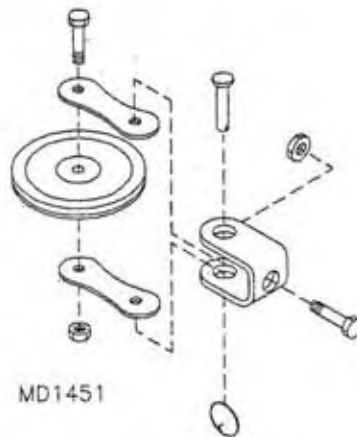
5. Bolt the control stick torque tube to the square tubes welded into the belly of the cockpit cage. Use the pillow block's second hole as a guide to locate and drill through the 1/2" square tube for the second bolt.
6. On the top of the cockpit cage on center near the forward spar carry through is the control tee swivel bushing. Assemble the flange bearing to the control tee by inserting on-half of the flange in the tee's center hole. Transfer drill six #30 holes into the tee. Test the fit of the flange bearing by clecoing the unit to the tee. Insert a 1/4" bolt, if it feels tight with no play rivet bearing to tee with (6) 1/8" aluminum pop rivets. If play is present, insert thin 1/4" washer between the bearings. The tee should spin freely once bolted in place on the top side of the bushing. See **Figure 05-06**.

**FIGURE 05-06**



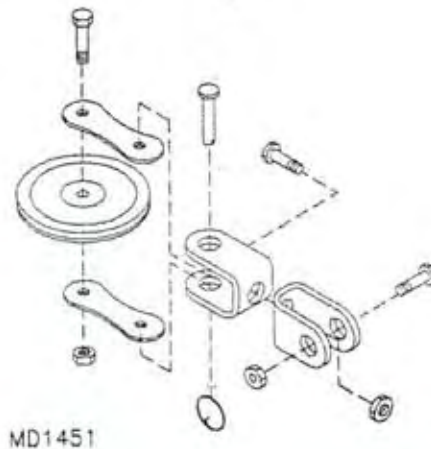
7. Bolt together four pulley assemblies as per **Figure 05-07**. **PLEASE NOTE:** The small shackles go on the outside of the tangs coming off the pulleys. Install a nut finger tight on the bolt through the pulley so the aileron cables can be inserted later. On the remaining four pulleys assemble them with the second shackle omitted. Please see **Figure 05-07A**.

**FIGURE 05-07**



**PLEASE NOTE:** REFER TO PARTS PAGE FOR PARTS.

**FIGURE 05-07A**



**PLEASE NOTE:** REFER TO PARTS PAGE FOR PARTS.

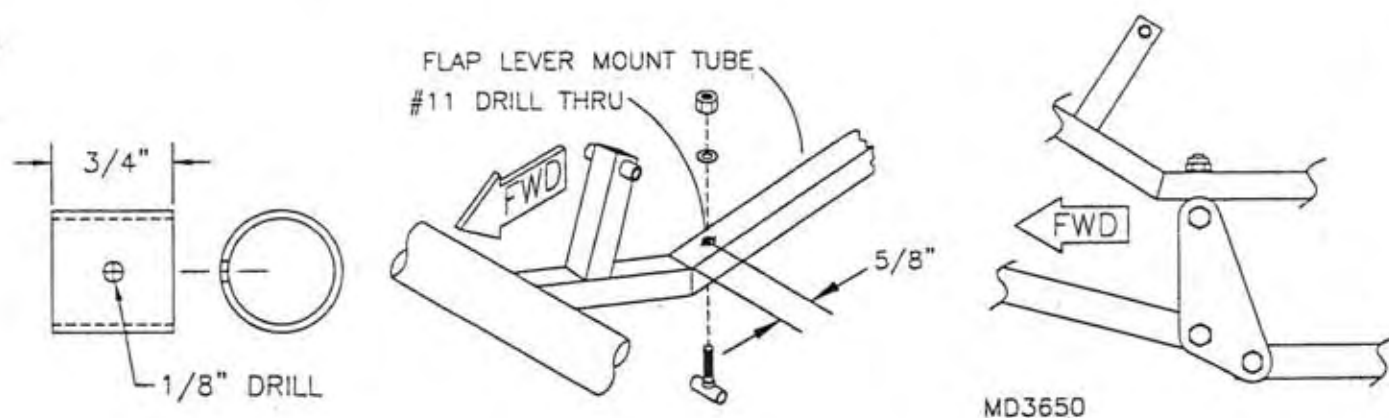
8. Install pulleys to locations in Fig. 05-08. Four locations are small bushings welded to cage. Note: pulleys which bolt to S-3 crossing tubes have nuts which are placed inside shackles. Insert bolt and finger tighten as much as possible. Use pliers to squeeze shackle tight against nut to tighten completely.

9. Route aileron cables per Fig. 05-08. Tighten turnbuckles slightly and test-run system. Check for smooth, free movement. If everything is lined up it will operate with very little friction. If it binds or catches, inspect system for dragging pulley or gross misalignment. Once satisfied the system runs properly, tension cable so it produces low note when strummed. Excessive tension causes high system friction; too little tension allows play in system. Adjust turnbuckles as necessary.

10. Inspect all connections before flying. *Check controls before flight! Moving stick right should raise right aileron and drop left aileron; moving stick left should raise left aileron and drop right aileron.*

11. Assemble elevator push-pull tubes, side plates and associated hardware per parts drawing. Fabricate elevator stop sleeves from raw stock per Fig. 05-11. Slip one sleeve onto 32" push-pull tube before inserting tube through centerline bushing on S-3 truss; slip other sleeve onto tube aft of bushing. (Sleeves will be riveted in place during tail assembly.) Drill #11 hole 5/8" aft of bend in flap lever mount tube (between seat rails); install push-pull assembly to flap lever mount tube per Fig. 05-11 and to control stick torque tube per parts drawing.

**FIGURE 05-11**



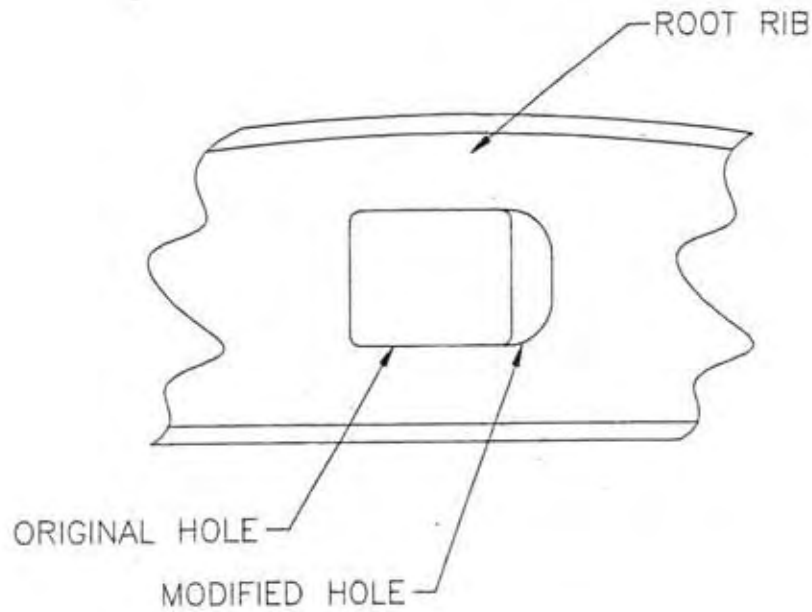
12. Check elevator push-pull tube assembly for smooth operation. Oil all pivot bushings and pillow blocks with a light machine oil. Keep these areas clean and well lubricated.

13. Insert push-pull tube end fittings into their respective 3/4" diameter aileron push-pull tubes. Drill through #40 pilot holes with #30 bit and rivet with 1/8" stainless steel rivets.

14. Aileron control system can be completed only after installing wings. We recommend attaching wings before covering, because it is much easier to set washout and rig flaps and ailerons.

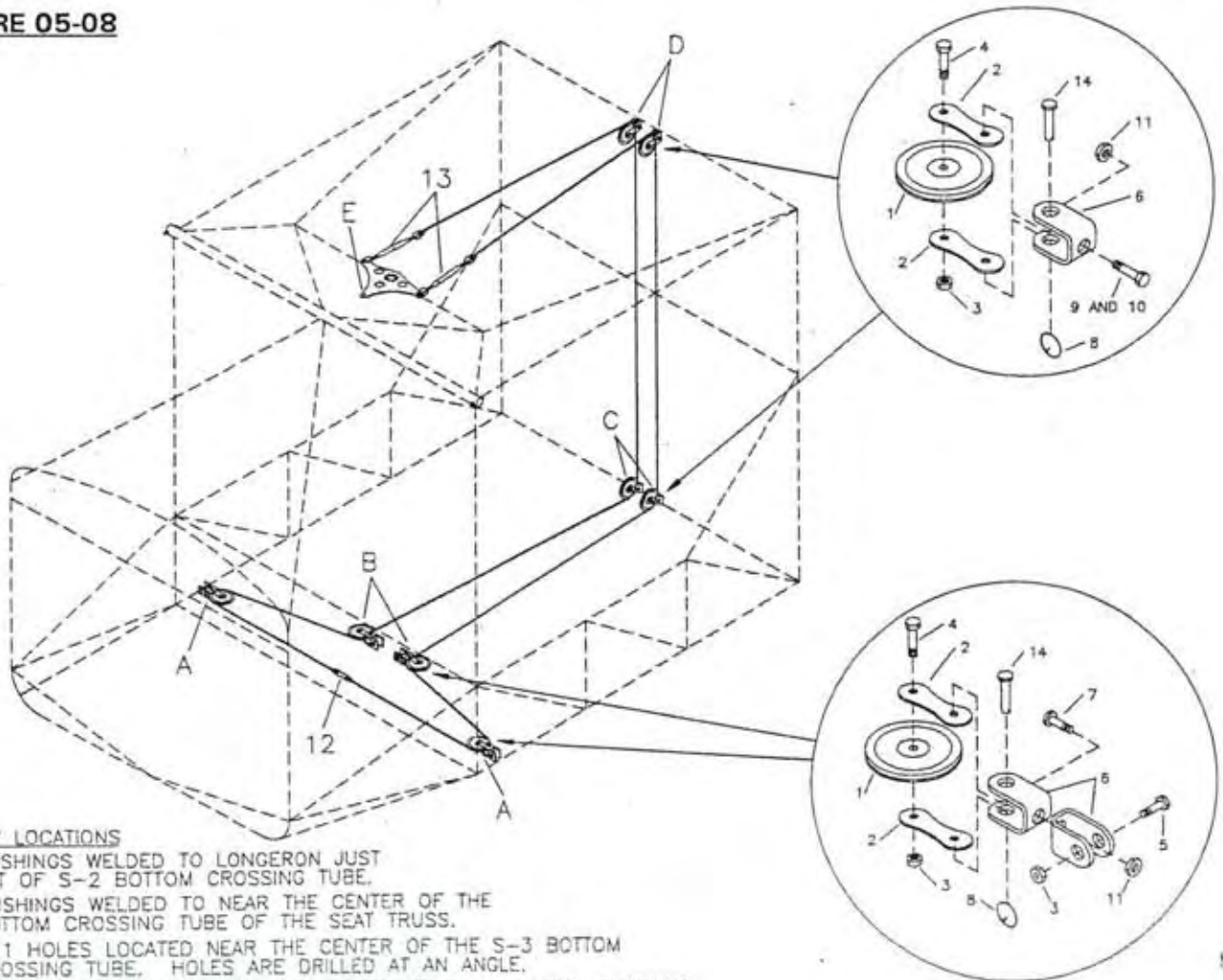
Note: It may be necessary to modify root rib cutouts as shown in Fig. 05-08; this allows aileron push-pull tubes to move without restriction.





MD1409

**FIGURE 05-08**



MD1409

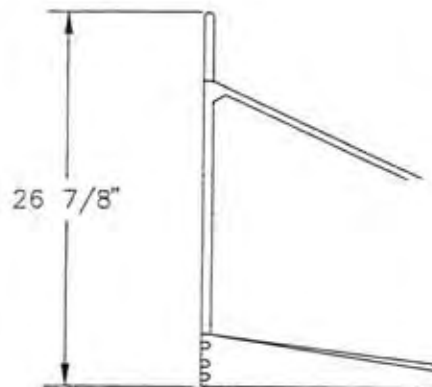
**PULLEY LOCATIONS**

- A. BUSHINGS WELDED TO LONGERON JUST AFT OF S-2 BOTTOM CROSSING TUBE.
- B. BUSHINGS WELDED TO NEAR THE CENTER OF THE BOTTOM CROSSING TUBE OF THE SEAT TRUSS.
- C. #11 HOLES LOCATED NEAR THE CENTER OF THE S-3 BOTTOM CROSSING TUBE. HOLES ARE DRILLED AT AN ANGLE.
- D. #11 HOLES LOCATED NEAR THE CENTER OF THE S-3 TOP CROSSING TUBE. HOLES ARE DRILLED AT AN ANGLE.
- E. CONTROL TEE. SEE PUSH PULL TUBES.

## S-6ES & S-6XL COYOTE II FIREWALL ASSEMBLY

1. Select the required parts for the firewall assembly shown on the parts page.
2. Fabricate (2) 3/4" x .058 x 1" reducers and (1) 3/4" x .058 x 4" splice tube. **HINT:** Oval the splice tube slightly (use a mallet) to assure it stays in position. The firewall rivets will hold the tube in place.
3. Set the reducers over the stubs on top of the S-1. Insert the splice tube halfway into a S-1 top former, then assemble with the other former. Set the assembly onto the stubs and reducers. Measure from the very bottom S-1 crossing tube to the very top of the S-1 former. It should measure 26 7/8", adjust accordingly. See **Figure 06-03**.

**FIGURE 06-03**



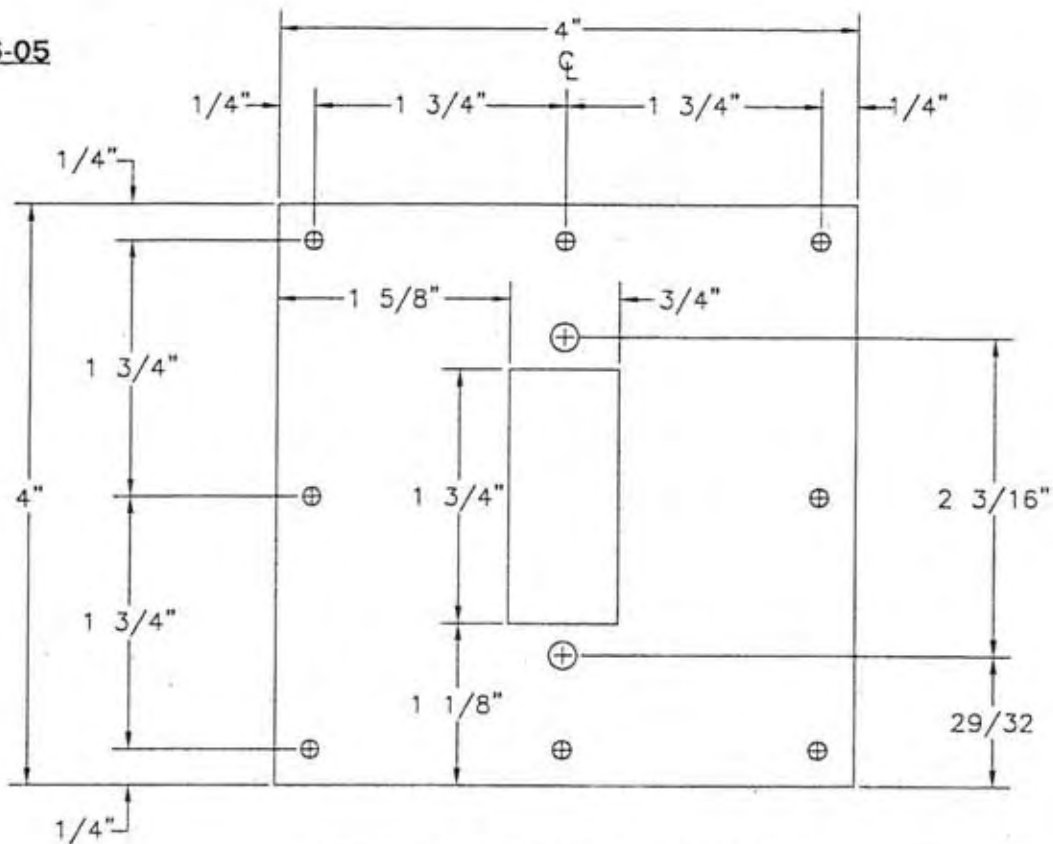
MD527

4. Clamp the firewall to the front of the S-1. Position so it is on the tubes with equal overhangs. Lay out, center punch, drill and cleco (do not rivet). Do not **DRILL** the top until step #9.

### **912 INSTALLATION SKIP THIS STEP**

5. Locate and drill the holes as shown in **Figure 06-04**. Make the slots by drilling 1/4" diameter holes in each corner then jig saw or tin snip between. **HINT:** An alternate method is to drill a series of 3/32" holes as close to each other in a row outlining the slot. Then force the drill sideways hole to hole. File to fit the starter pulley. Cleco the plate to the firewall with the pulley on the **FRONT** side with the rope feed end down. See **Figure 06-05**.
6. Drill through the firewall with a 1/4" drill at the two top engine mount bushings. **HINT:** Use a wood block pressed against the front side of the firewall to gain support and prevent burring. Bolt the engine mount to the top two locations. Clamp the lower mount attach points firmly against the frame. Drill through the lower attach points with a 1/4" bit using the engine mount as a guide. Remove mount for future installation.
7. Uncleco the firewall, remove it to clean out shavings and debur holes. Position the firewall soundproofing with the dark fabric facing inside against the S-1. Re-cleco the firewall in place. Poke through with an ice pick and rivet the firewall in place. Rivet the pulley plastic face plate on the inside over the soundproofing. Trim off excess soundproofing and heat seal with a soldering iron. **HINT:** Use soldering iron or hot knife to melt open the holes for the grommets. **PLEASE NOTE:** Use the longer 1/8" aluminum pop rivets to attach the windshield and cowling hold down strips.

FIGURE 06-05

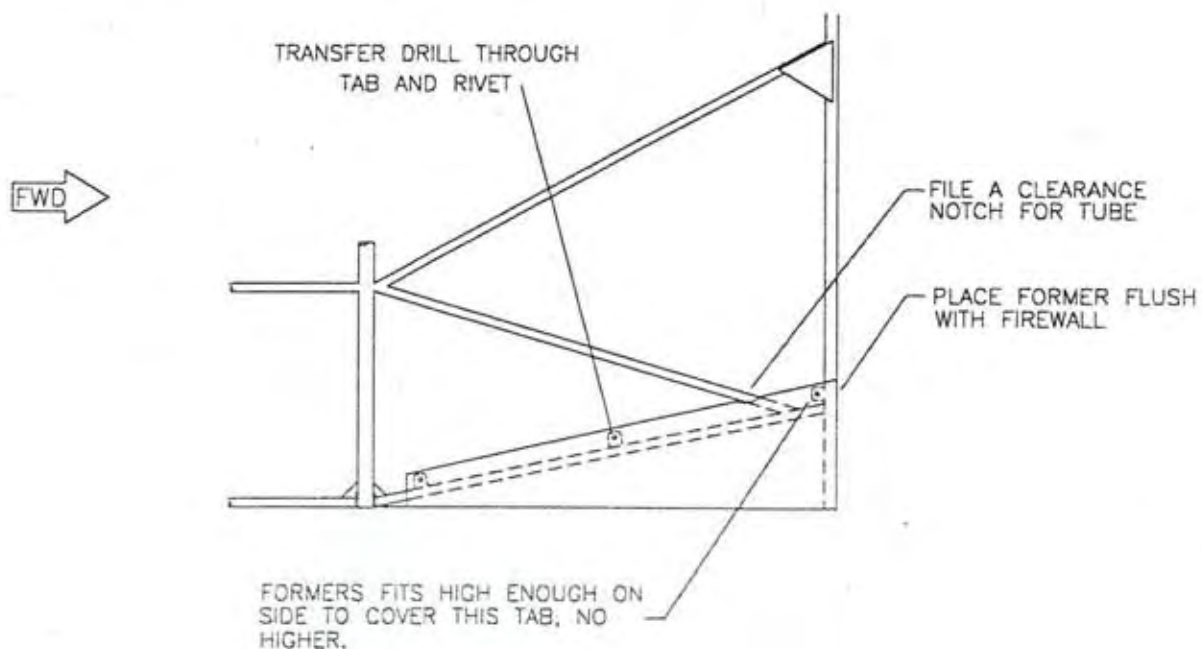


DRILL ALL PERIMETER HOLES 1/8"  
 DRILL PULLEY RIVET HOLES #11

MD528

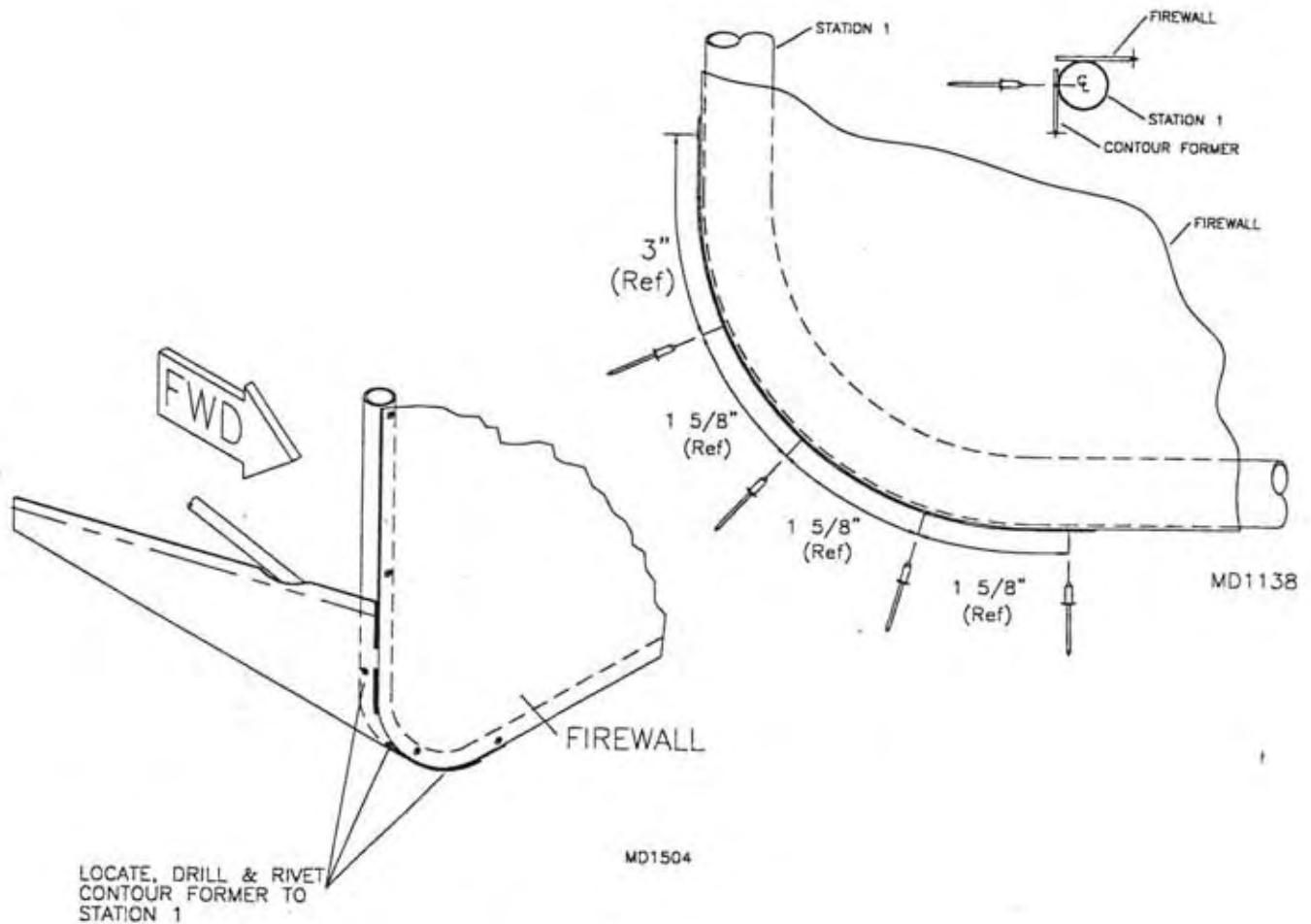
8. Bend the forward contour formers over a 2" tube to shape. Place the formers in position as shown in Figure 06-08. Drill #30 from the inside through the tabs located on tubes. Drill (4) #30 holes around curve of the S-1. See Figure 06-08A and rivet.

FIGURE 06-08



MD1515

FIGURE 06-08A

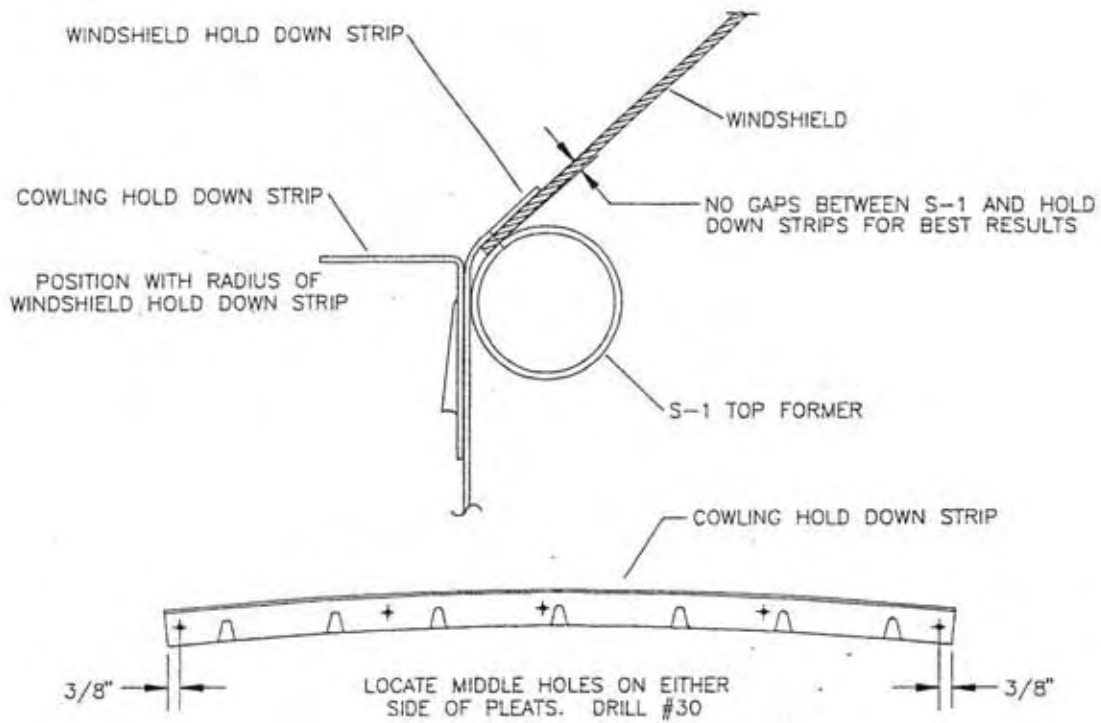


9. Bolt the S1-LUT to the #11 holes drilled through the top of the S-1.
10. Snap in place the rubber grommets in their respective holes working in the soundproofing.
11. Lay out the windshield and cowling hold down strips as per **Figure 06-011**. Set these against the firewall's top with the proper space (as in **Figure 06-011**) and rivet to complete the firewall installation. **HINT:** Temporarily set the windshield in place to set up proper thickness spacing off of S-1. Cowling fit is critical to this step. Please take care not to **INCREASE** firewall height or the top cowl will not fit. Overall height should be 26 7/8". See **Figure 06-03**.
12. To retain the cowling sides, install 3/16" nut plates to the **INSIDE** of the tabs on the sides of the S-1.

### HEAT SHIELD INSTALLATION

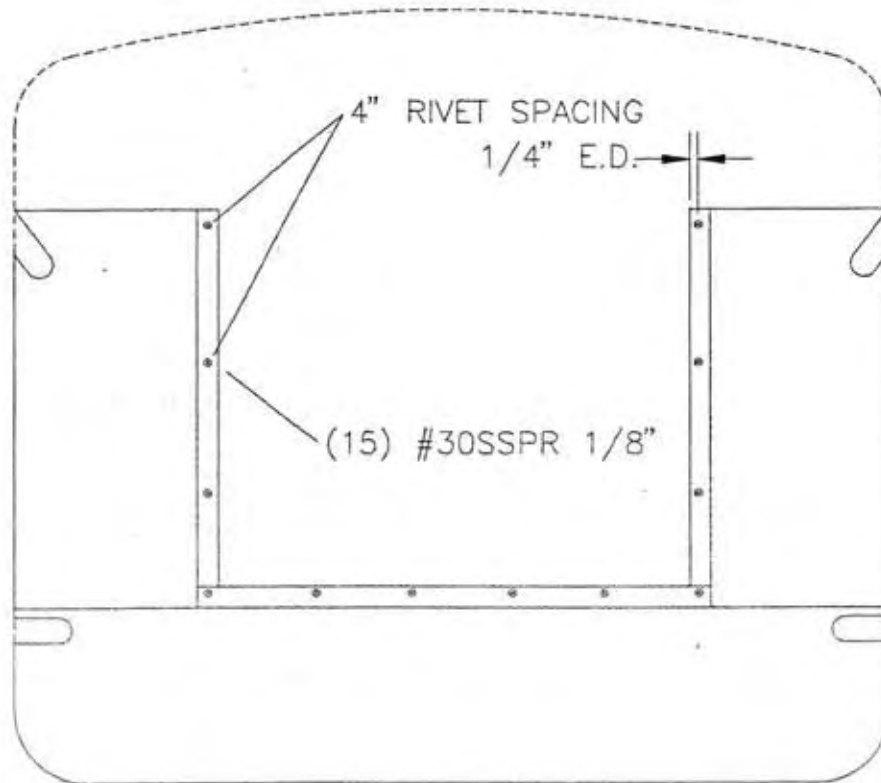
13. Slip the heat shields under the engine mount. The heat shields are flush with the outside of the firewall. Layout and drill #30 holes as shown in **Figure 06-13**. Cleco the heat shields on. The bottom heat shield may need to be trimmed to fit. Remove the heat shields for covering, after covering, rivet shields with 1/8" aluminum pop rivet.

**FIGURE 06-011**

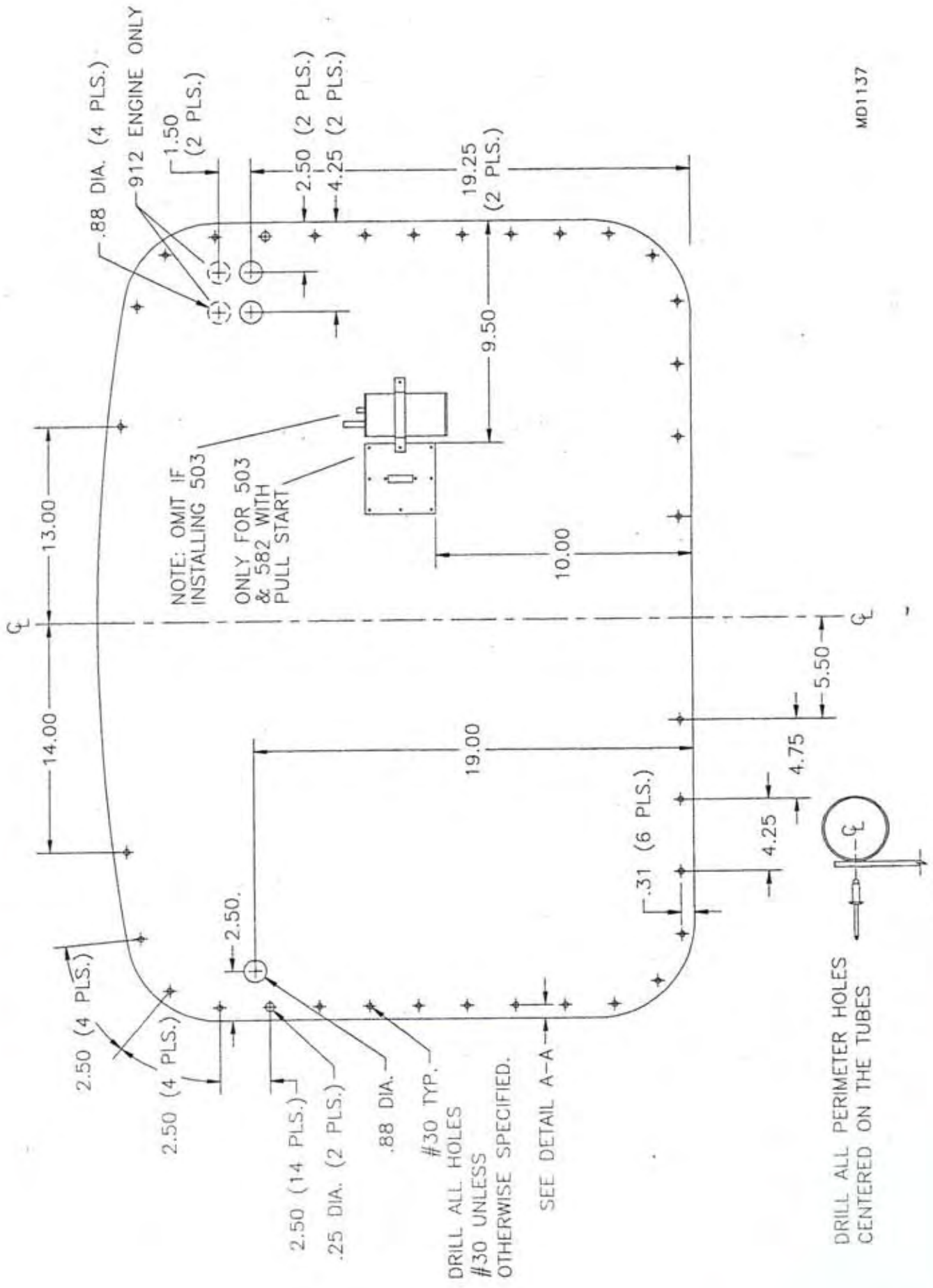


MD1320

**FIGURE 06-013**



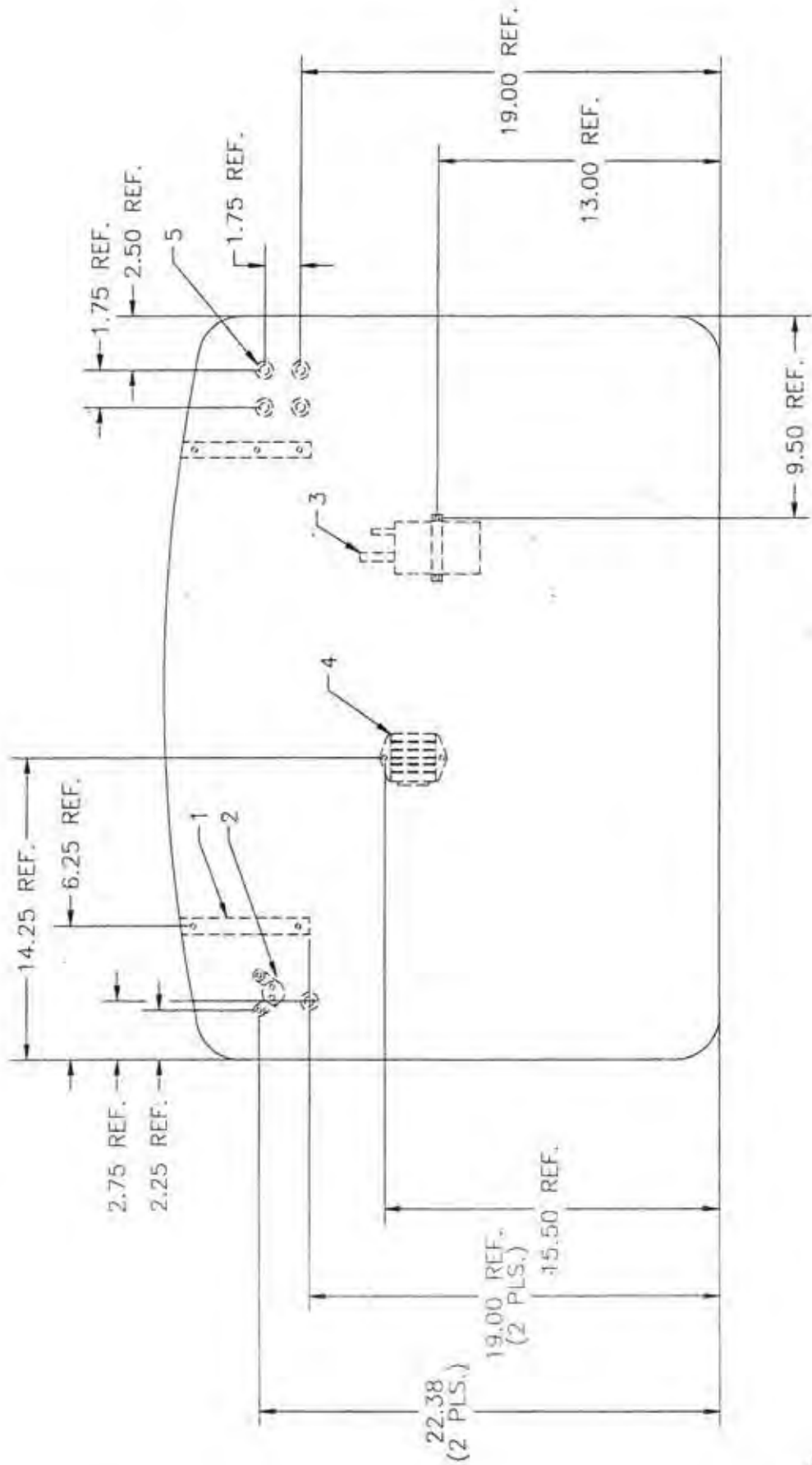
MD1320



MD1137

DETAIL A-A

- 1. RADIATOR MOUNT (QTY. 2)
- 2. SOLENOID
- 3. COOLANT RECOVERY BOTTLE
- 4. REGULATOR/RECTIFIER
- 5. RUBBER GROMMET (QTY. 5)



MD546

S-6ES COYOTE II AILERON AND FLAP ASSEMBLYFLAP SYSTEM ASSEMBLY

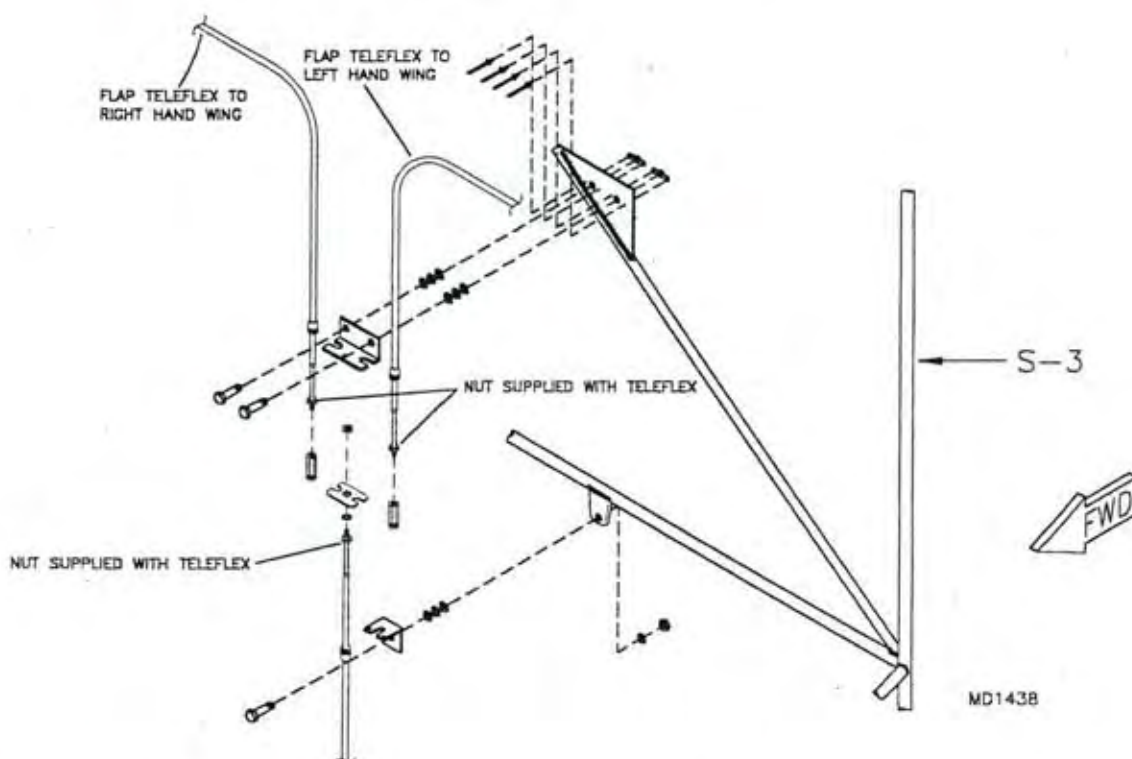
1. Fabricate the following bushings to the appropriate lengths:

<u>Qty.</u>	<u>Length</u>	<u>Tube Size</u>
1	7/8"	1/4" X .028
2	3/8"	3/8" X .058
2	9/16"	1/4" X .028

2. Press the plastic caps into each end of the 3/4" flap trip release tube.
3. Screw the rod end onto one end of the 8ft. teleflex cable. Using the plastic shim, teleflex retainer and 9/16" long bushings, bolt this end of the teleflex to the flap lever side plates inside right hand side as per the parts drawing. Note that the S2-SAB bolts to the lower hole. Bolt the 7/8" bushing into the side plates top hole.
4. Bolt the flap lever between the two side plates with the welded tab facing down. Tighten the flap lever pivot bolt so it is snug, but still allows the lever to pivot freely. Slip the spring into the flap lever tube and install the flap trip release tube.
5. Depress and rotate the flap trip release tube until the 1/4" hole is lined up with the slot. Install the bolt and 3/8" diameter bushings into the flap lever and trip release tube. The bushings act as rollers and will ride against the flap lever sides. Tighten the bolt to the point the bushings still roll. Apply a light grease to the rollers for the best action. Test operate the lever by pulling up on the lever, then depressing the flap release tube return.
6. Bolt the teleflex rod end to the right hand side of the welded tab on the flap lever. The exact adjustment of the rod end on the teleflex will be determined when adjusting the flaps.
7. Install the flap lever assembly into the cockpit by slipping the forward part of the assembly over the attach fitting located between the seats on the airframe. Refer to the parts drawing. Using the hole in the S2-SAB as a guide, mark the hole location onto the steel mount tube. Pivot the flap lever assembly up and drill the #11 hole. Pivot the flap lever assembly down and bolt the S2-SAB to the mount tube.
8. Bolt the lower teleflex retainer to the tab located on the left hand side of the station 3 mid cross tube. Refer to the parts drawing and to **FIGURE 07-08**. Route the teleflex from the flap lever to the lower retainer. It must loop under the baggage compartment and rest on the bottom cross tubes and diagonals aft of station 3 in the tailcone and should not interfere with any other control systems such as the rudder and aileron cables. Install the teleflex into the lower retainer. Safety wire or make a brass wire clip to hold the teleflex in the retainer.
9. Slip the flap cover over the handle to cover up the roller ratchet section of the lever. Use the conveniently located pockets to store items such as an intercom box or a flashlight. **NOTE:** Pocket on left hand side will need to be removed if using bungee elevator trim wheel.



FIGURE 07-08



10. Install the aft dual teleflex retainer onto the flap teleflex and secure with the **TENSILE** nut. The jam nut is supplied on the teleflex. It is important that this jam nut be in place prior to installing the dual teleflex retainer. Final adjustments will be made to the retainer during flap rigging.

11. Position the forward dual teleflex retainer vertically in line above the aft dual teleflex retainer and clamp to the mount tab located on the station 3 upper diagonal. See **FIGURE 07-08**. The positioning of the retainer must also allow the installation of the nut plates. Using the retainer as a guide, mark the mount hole locations onto the tab. Remove the retainer and drill the mount holes in the tab to #11. Install the nut plates and bolt the retainer in place. Note that the retainer will have to be removed prior to skinning the fuselage.

12. **PLEASE NOTE:** The flap teleflexes should exit the wing as far **AFT** as possible. This allows the cables to stay attached when folding the wings. After the wings are installed, slip each flap teleflex into the forward retainer. Install the flap nuts and insert them into the aft retainer. Secure the teleflexes into the retainers with nylon ties or safety wire.

13. Rig the flaps by adjusting the rod ends and tensile nuts. Both flaps should be even when viewed from the front or aft center. To properly rig the flaps, all three teleflex cables may require adjustment. It may also be required to trim off the ends of the teleflex cables where they attach to the horns.

During flight testing, if the aircraft tends to roll to the right or left, flap adjustment may be required. Refer to the rigging section for further instructions.

## STD. AND 116 AILERON & FLAP FRAME ASSEMBLY

### PRE-COVERING ASSEMBLY

1. All hinge, control horn and tensioning hole locations are predrilled in the leading edge spar and the tensioning compression tube of each flap and aileron frame. Prior to covering the ailerons and flaps, drill all holes to a #11. **NOTE:** Drill the flap root hinge hole to 1/4". Install the nut plates to the interior side of the leading edge spar as shown in the parts drawing. Retain the trailing edge spar into the compression tubes with masking tape wrapped around the trailing edge spar and onto the compression tube. The flaps and ailerons are now ready to cover. Refer to the covering section. After covering, refer to this section for final assembly and installation of the flaps and ailerons.

### AILERON & FLAP FINAL ASSEMBLY AND INSTALLATION

2. Using a hot knife cut the gap seal at each hinge point as shown in **FIGURE 07A-02**. Do not cut into the stitching. Melt through the hinge holes and control horn attach angle bolt holes.

Assemble the control horn attach angles to the ailerons and flaps. The vertical flange of each angle should be toward the tip end. Fabricate the aluminum bushings to the dimensions described on the parts page. Position the aileron clip and bushing on the trailing edge spar 90 degrees to the leading edge spar and in line with the vertical forward attach hole. See **FIGURE 07A-02A**. **NOTE:** For 116 flaps and ailerons position the attach angles parallel to the slipstream.

**FIGURE 07A-02**

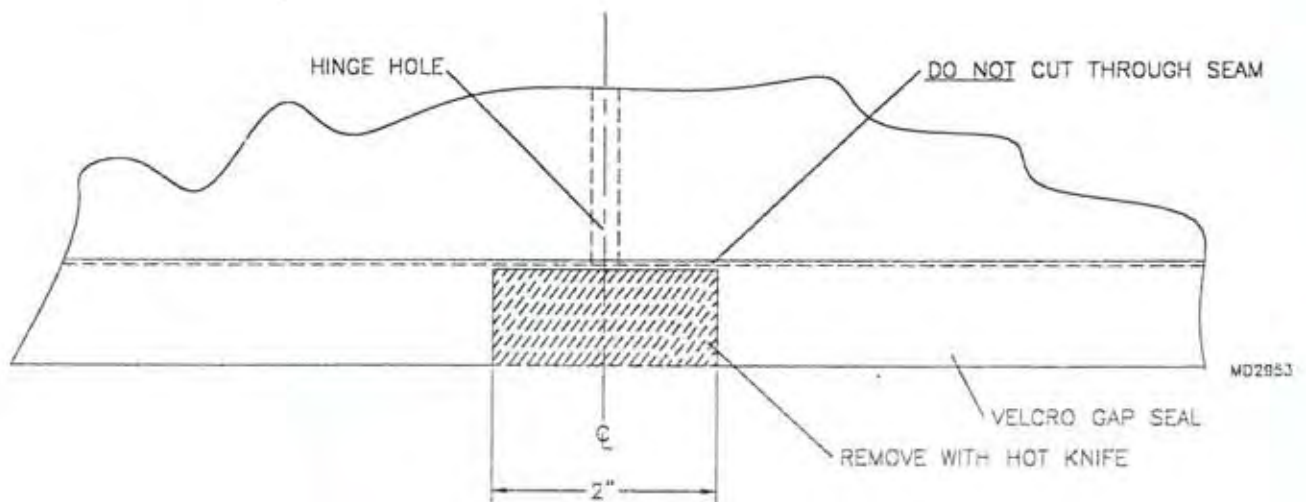
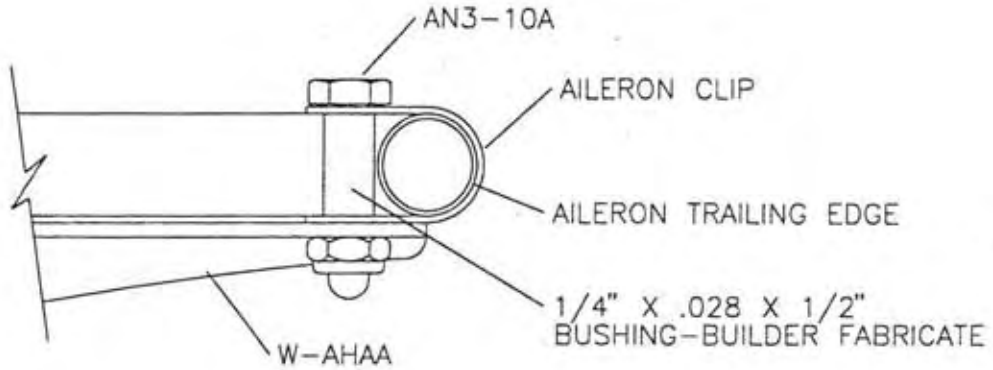


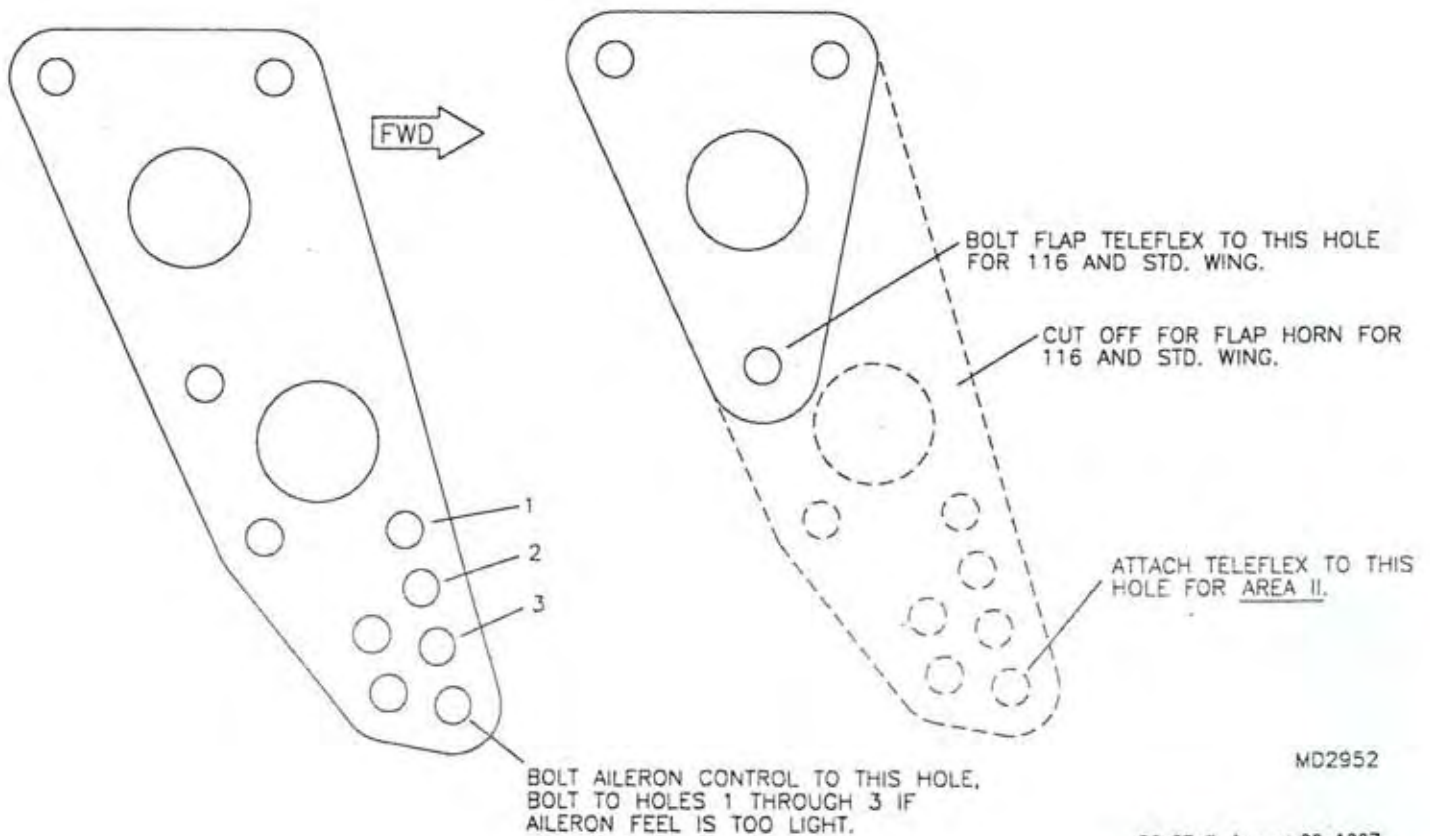
FIGURE 07A-02A



MD1482

3. Modify the **FLAP** unihorn as shown in **FIGURE 07A-03**. Assemble the uniorns to the flap horn attach angle. Assemble the unmodified uniorns to the aileron attach angles. Note the correct orientation and positioning of the uniorns. Refer to the parts drawing.

FIGURE 07A-03



MD2952

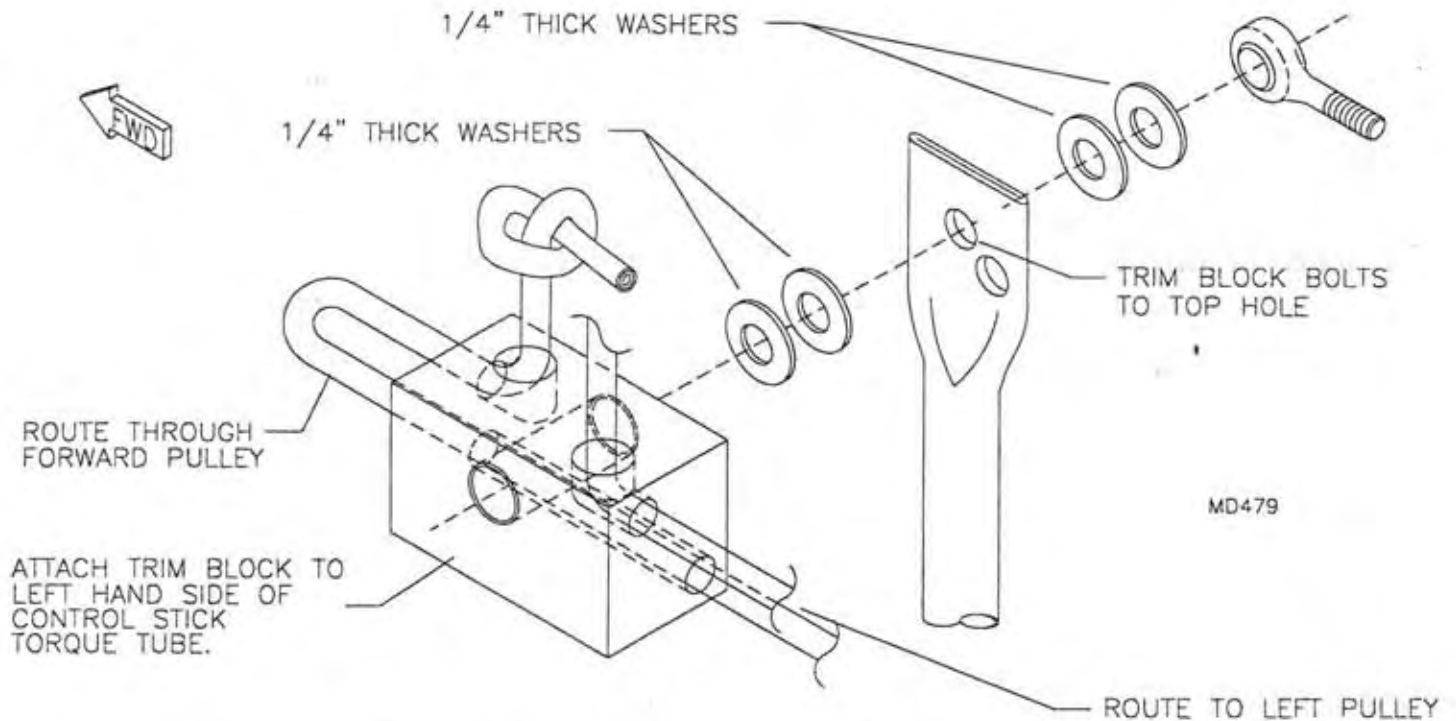
4. Install the plastic end caps into the tip end of the aileron and root end of the flap leading edge spar as shown in the parts drawing. The end caps can be secured with a single #40 rivet.
5. Install the hinges onto the wings, flaps and ailerons and attach the flaps and ailerons to the wings using the hardware called out in the parts drawing. **NOTE:** Drill the hinge mounting holes to #11. Drill the **flap** root hinge mounting hole to 1/4". The flaps and ailerons may be shifted to either side of the hinges to achieve the best spacing. Some of the hinges may not line up. In this case shimming with washers is required. Place a small drop of light oil on each hinge. Ailerons and flaps must hinge freely, do not over tighten the hinge bolts. Prior to connecting controls, test the aileron and flap by holding the surface up by the trailing edge and letting go. The aileron and flap should swing freely.
6. Refer to the covering section for the aileron and flap control exit dimensions. Refer to the wing section for connecting the push pull tube and teleflex. Refer to the wing section for rigging instructions.

## S-6ES COYOTE II STANDARD TRIM SYSTEM

**NOTE:** The instrument panel, control stick torque tube and flap lever must be installed prior to installing the trim system. Refer to the instrument panel, control stick and flap lever sections for details.

1. Bolt the trim block to the left side of the center arm on the control stick torque tube. Note that when installing the standard bungee trim system the top hole in the torque tube is used. Refer to **FIGURE 07B-01**. Note the orientation of the trim block. It is important the aluminum bushing be installed in the trim block. The bushing enables the tightening of the mounting bolt while allowing the block to rotate.

**FIGURE 07B-01**



2. Fabricate and install the aluminum bushing into the trim wheel as shown in the parts drawing. The bushing must be slightly shorter than the trim wheel and hub. Melt through the left side of the flap lever cover at the proper bolt location. **NOTE:** The pocket on the left hand side of the flap lever cover must be removed prior to attaching the trim wheel. Bolt the trim wheel to the left side of the flap lever assembly. Do not pinch the cover between the trim wheel hub and flap lever side plate. Note that this bolt also retains the flap lever. This bolt should be tight enough to retain the bungee at any setting and still allow free movement of the flap lever.

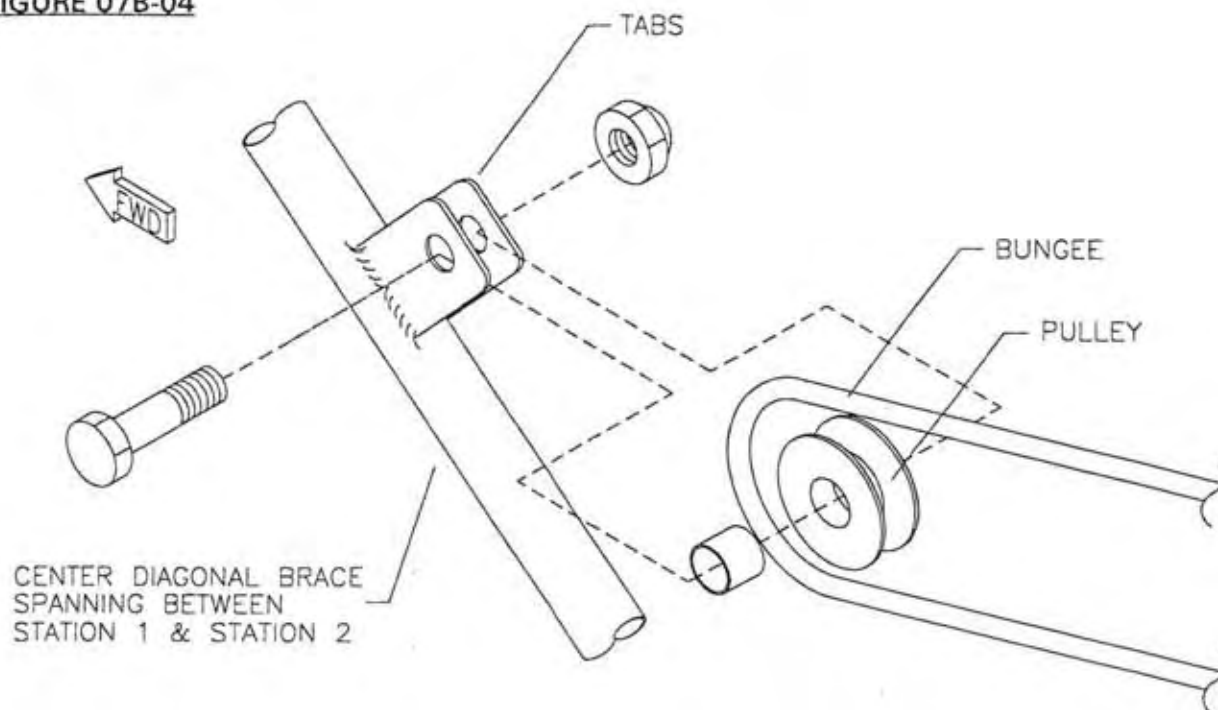
3. Bolt the brake mount bracket to the upperside of the square tube with the flap pivot bushing, just below the flap lever. Refer to the parts drawing. Align the second hole in the bracket on centerline of the tube. Transfer drill and bolt in place.

Bolt the aluminum bushings, plastic pulleys and washers to the bracket. The pulleys should rotate without binding.

4. Bolt the forward pulley and bushing between the two tabs welded to the center diagonal located

between station 1 and station 2. See FIGURE 07B-04.

**FIGURE 07B-04**



MD479

5. Insert one end of the bungee through the hole in the AFT end of the trim block, pull it up through the larger hole in the top and tie off with a single knot. Route the bungee aft under the left pulley and up to the forward side of the hub on the trim wheel. (This will tighten the bungee when the trim wheel is rolled back resulting in up trim.) Wrap the bungee three to four times around the hub and down to the right hand plastic pulley. Route the bungee forward, completely through the trim block to the forward pulley. Note that both legs of the bungee pass under the seat truss. Pass the bungee through the pulley from the bottom side, over the top and back to the trim block. Insert the bungee into the hole in the forward side of the trim block and up through the larger hole. Tie a single knot to retain.

6. The trim system operates by exerting tension on either side of the elevator horn on the control stick torque tube. The bungee must be tight for the trim system to function properly. Tension the bungee to the point that it will not slip on the trim wheel hub. The bolt that holds the trim wheel to the flap lever mechanism must be tight enough to hold against the bungee at any setting. Trim off any excess bungee at the trim block with a hot knife.

7. Other factors effect trim such as C.G. and horizontal incidence. Refer to the tail section for setting incidence and the C.G. operation for C.G.

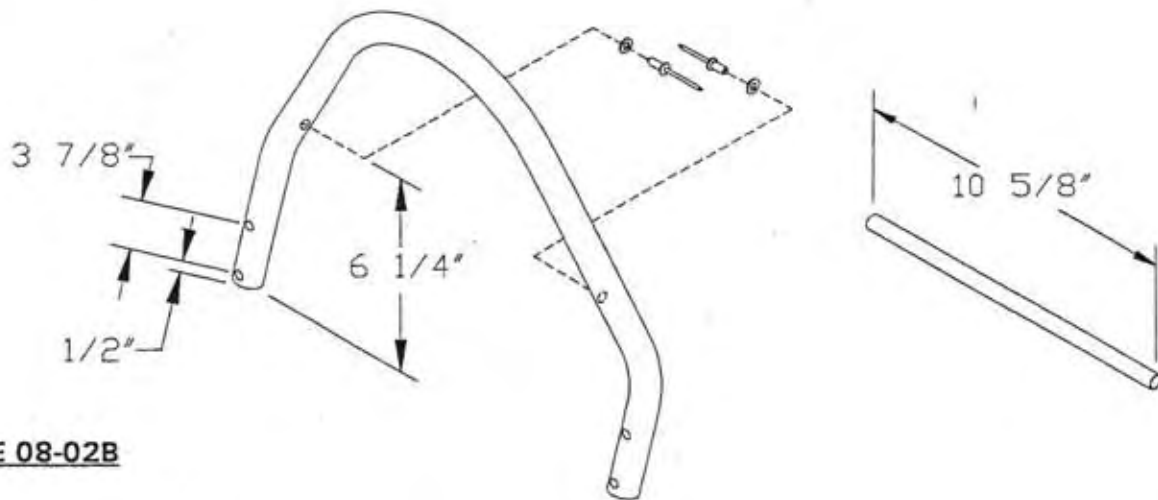
## S-6ES COYOTE II SEAT ASSEMBLY

There are two types of seats used. The flip up style is standard, with the fixed bottom optional. The fixed bottom style is used when extra head room is required. The seats can also be set up with one of each style. If you find you require a fixed bottom seat, please call our parts department for pricing and availability. Assembly of the seat back is the same either style. Please read the whole seat assembly section for instructions on both types.

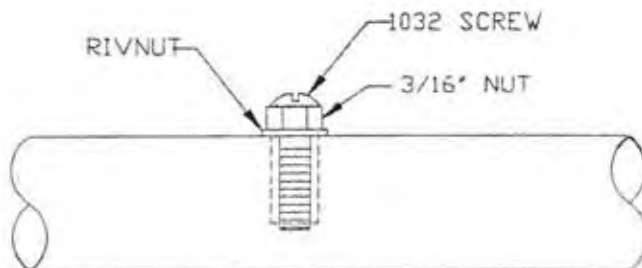
### FLIP UP SEAT ASSEMBLY

1. Select the parts as shown in the S-6ES parts drawing.
2. If you are installing the optional headrest mark and drill the headrest frame as shown in **Figure 08-02**. Install the buttons to the inside of the headrest frame as shown. Measure and mark up from the lower ends  $17\frac{1}{4}"$  on the seat frames' **BACK SIDE**. Drill a #11 hole through only the tubes' one side, on each side. See **Figure 08-02A**. Pin the headrest frame in place. Drill the second set of holes. Remove the headrest frame and drill the seat frame out to  $\frac{1}{4}"$  and install the rivnuts. See **Figure 08-02B**.

**FIGURE 08-02**



**FIGURE 08-02B**



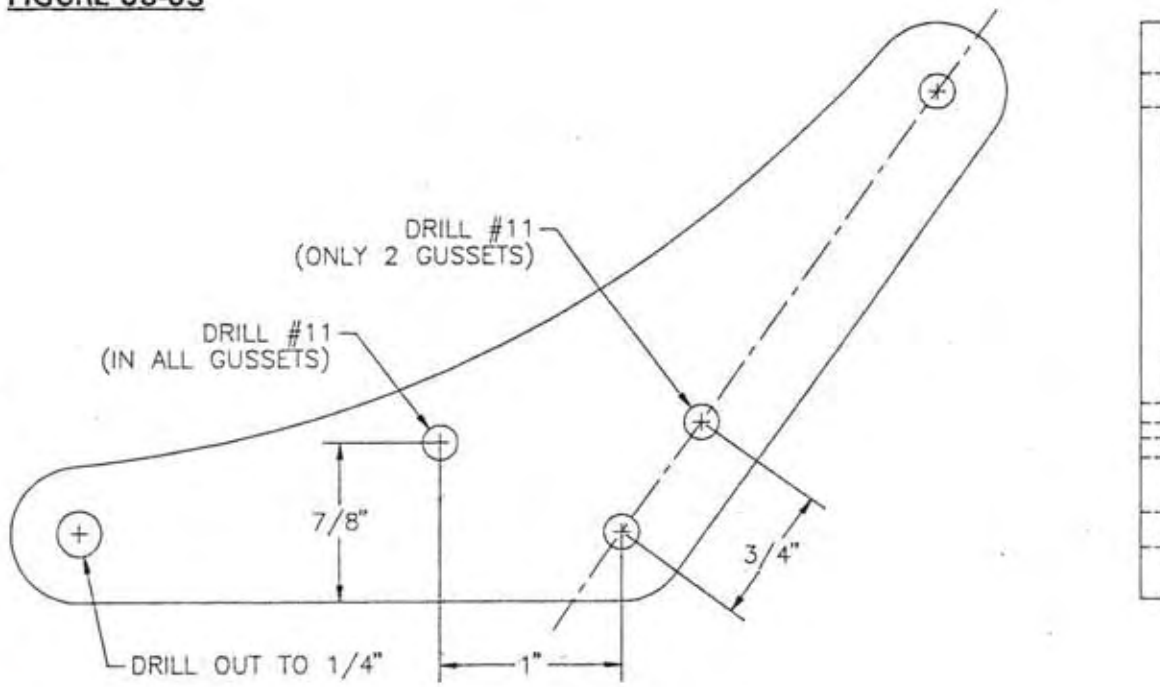
#### PROCEDURE:

1. FINGER TIGHTEN NUT AND RIVNUT ONTO SCREW.
2. INSERT RIVNUT INTO  $\frac{1}{4}"$  HOLE.
3. TURN NUT THREE TURNS CLOCKWISE WHILE HOLDING SCREW STATIONARY.
4. BACK NUT OFF HALF A TURN AND REMOVE SCREW.

3. Refer to **Figure 08-03** for hole size and locations. Drill the seat gussets and deburr.

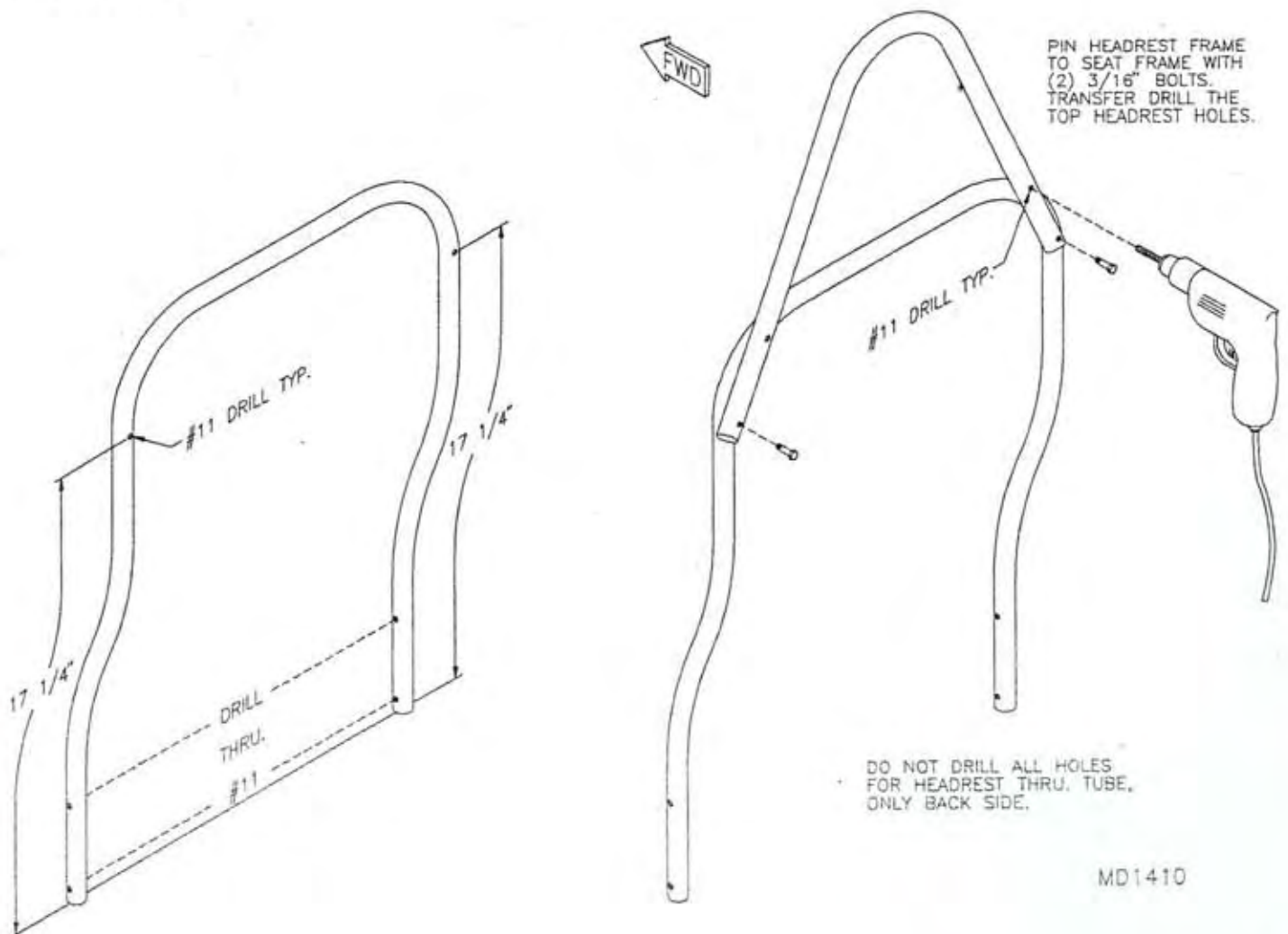
MD343

**FIGURE 08-03**



MD1410

**FIGURE 08-02A**



MD1410

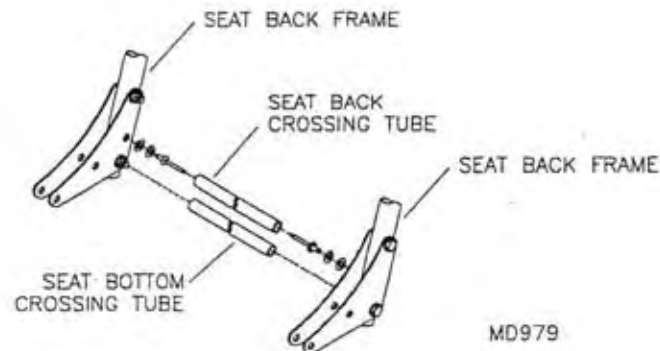


4. The doublers have been installed in the seat prior to the lumbar bend, but they need to be drilled. Drill through with a #11 bit using the frame as a guide. Bolt a set of seat back gussets to each seat back frame. Please orientate bolts so the nuts are facing inward towards each other.

5. Rivet a "button" to the inside of each seat gusset as shown in Figure 08-05. This button will serve to retain the crossing tube that supports the seat back bottom edge. The second crossing tube is retained by the bolts at the lower end of the gusset also shown in Figure 08-05. The second crossing tube is used to retain the seat bottom aft edge. Cut (4) crossing tubes 14" for the flip up style seat and (2) for the fixed type.

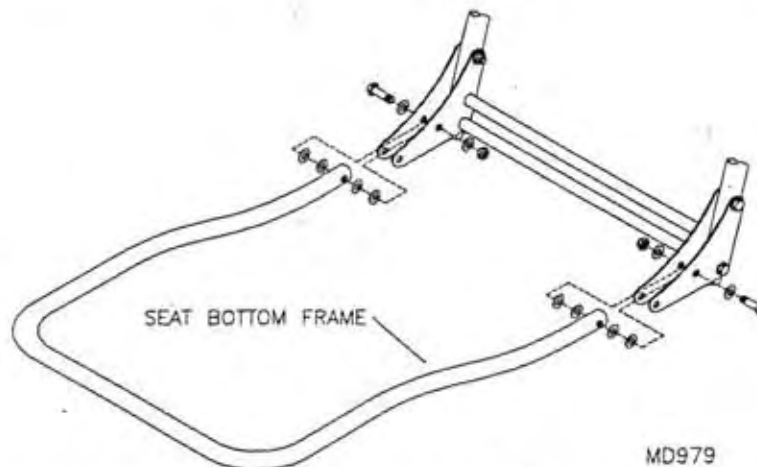
Assemble the crossing tubes by spreading the frame apart just enough to slip the tube over the nuts and buttons. If the tube does not bottom out against the gusset lay the assembly on its side and tap it gently with a mallet.

**FIGURE 08-05**



6. Assemble the bottom seat frame between the seat gussets. See Figure 08-06.

**FIGURE 08-06**



7. Slip the seat bottom onto the frame with the flaps facing down. Study Figure 08-07 for wire and zip tie placement. Use a hot knife or scissors to cut the notches. The seat bottom aft flap goes around the tube that is retained by the bolts. Do not pull the tie around the flap all the way tight. They must be a little loose to allow the seat bottom to fold down flat.

8. Slip the seat back onto the the frame with the pocket side to the aft. Study Figure 08-08 for notch locations. The seat back flap wraps around the remaining tube. Cut to length and bend the ends of the wires the same way as done for the bottom. Pull the zip ties tight once the fabric is in place.

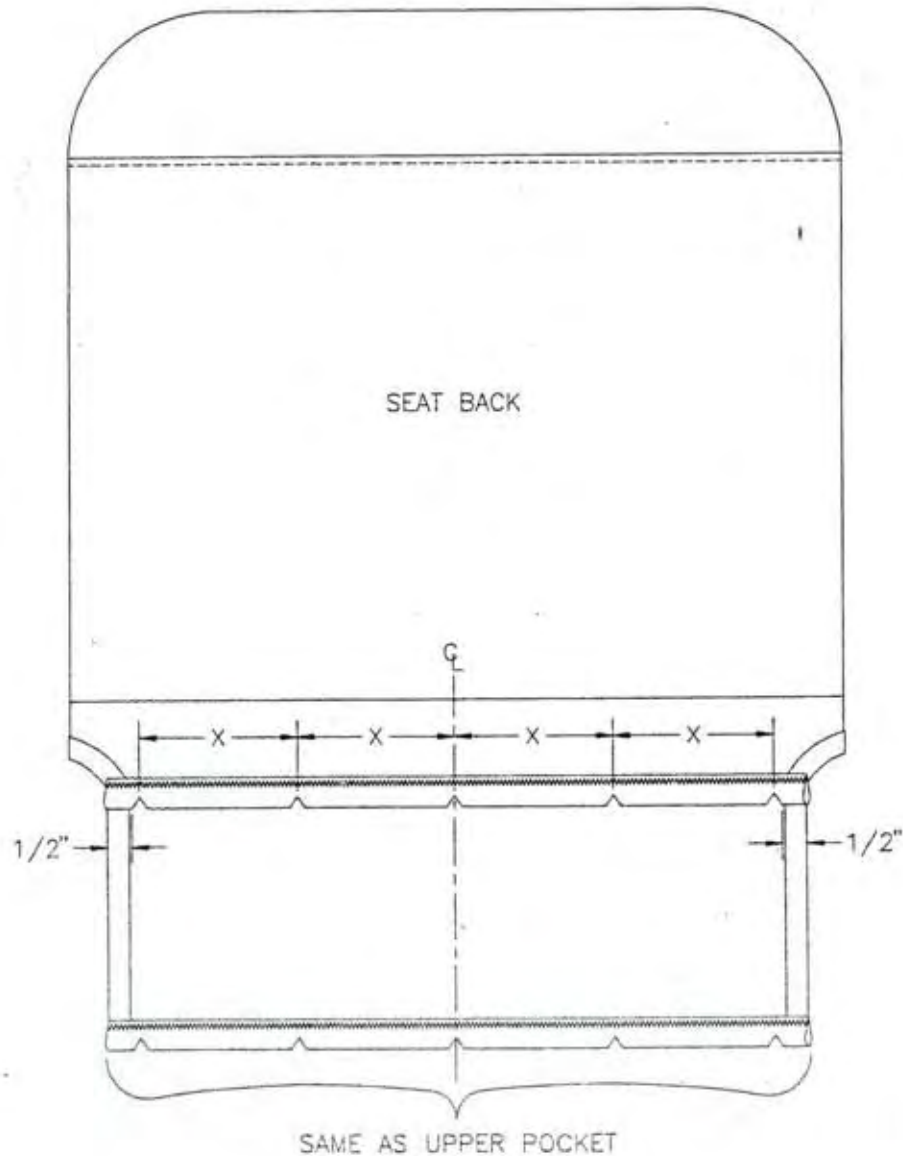
9. File the ends of the 1/2" tube to match the angle of the headrest frame for best fit. Snap the tube onto the buttons. Find the locations of the four rivnuts on the seat back frame and melt through with the tip of a soldering iron. Bolt on the headrest frame with the 1/2" tube in place. Slip the headrest cover over the frame and close the velcro.

10. Place the seat assembly in the fuselage. Position the seat so the gusset's lower open hole is lined up with the bushings welded to the bottom of the seat rails. Take a 1/4" clevis pin and test fit through the newly drilled hole. If it is tight, drill out the welded in place bushings with a 1/4" bit.

### FOR FIXED SEAT BOTTOMS

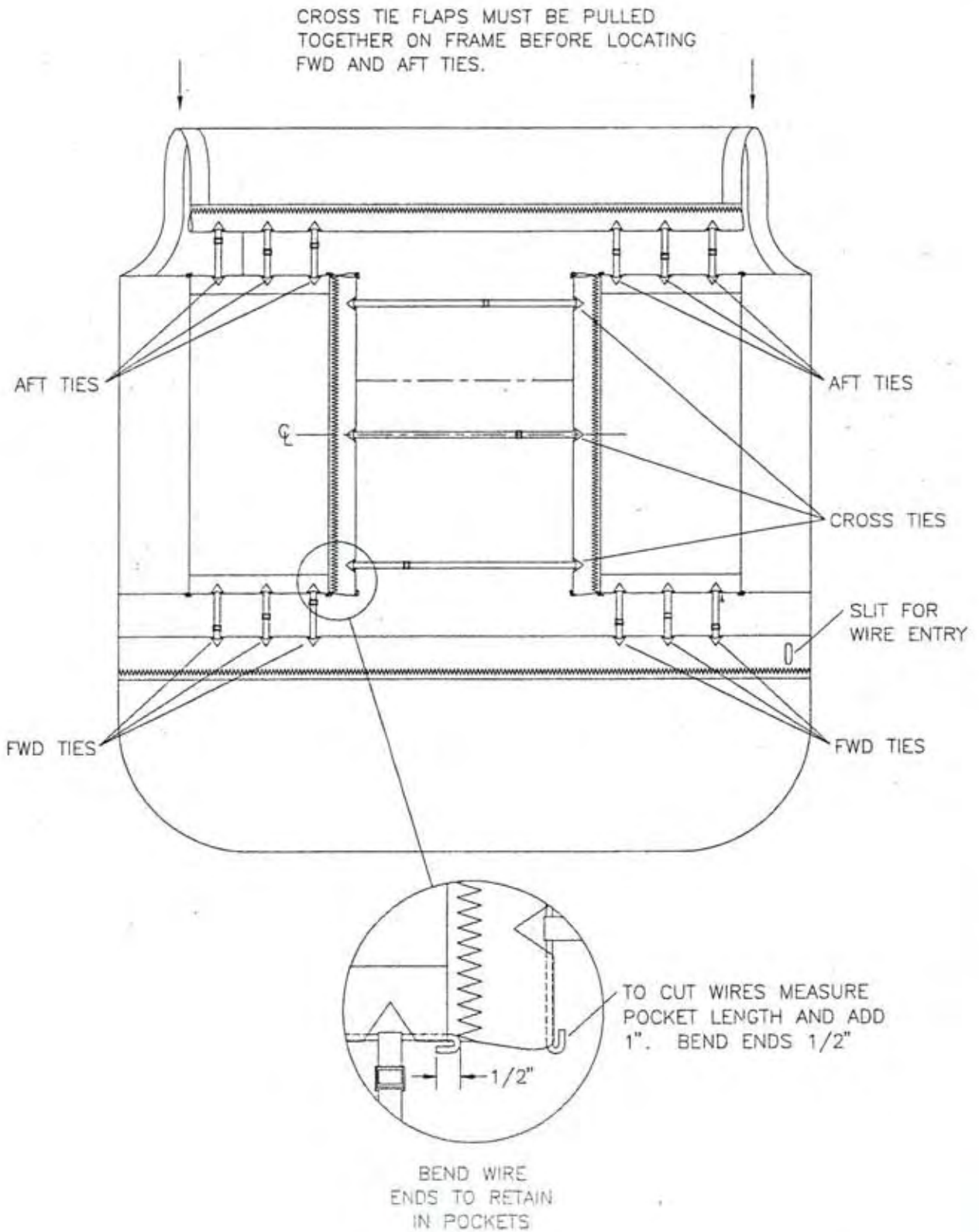
11. Take the seat bottom and position it on the fuselage frame. Lace the crossing straps first, followed by the front to back straps. Pull these straps as tight as possible without tearing them. **NOTE:** You may need to tighten these straps after a few hours of flying. Loop the extra strap back into the buckle and trim off the excess so only 2" to 3" remain.

FIGURE 08-07



MD807

FIGURE 08-08

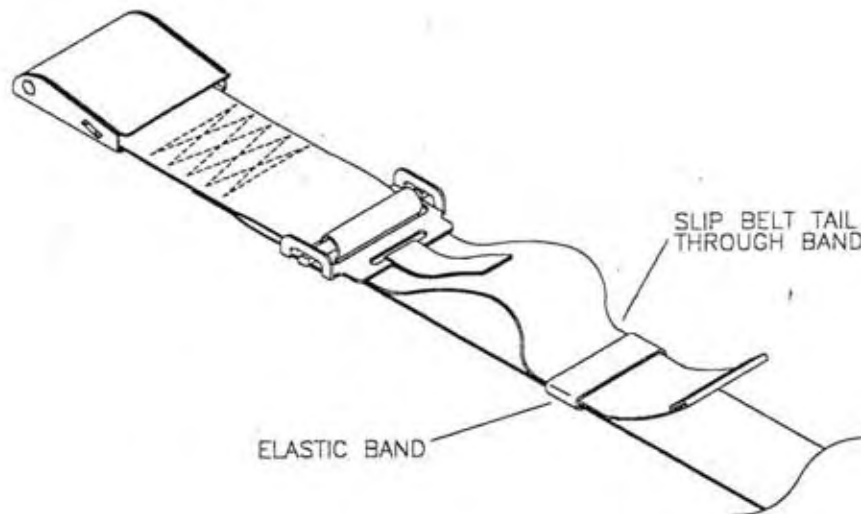


MD808

## S-6ES COYOTE II SEAT BELT ASSEMBLY

1. Prior to covering the fuselage, drill out to 1/4" the seat belt mount tabs welded to the fuselage. Refer to the parts drawing for the mount tab locations. Note that if you are installing the optional interior kit that the interior will need to be installed prior to installing the seat belts for the final time. Also note that if you are installing an interior, extension tabs will need to be bolted to the welded mount tabs on the station three top cross tube. Refer to the interior installation instructions in the options section of the manual.
2. After covering the fuselage bolt each belt to there respective mount as shown in the parts drawing. Use the elastic band on the lap belt to hold the tail of the belts after adjustment has been made. Refer to **FIGURE 08A-02**.

**FIGURE 08A-02**



3. This seat belt design allows for quick exit out of both lap and shoulder belt simply by opening the buckle. To use, simply pull belts over lap and shoulder and adjust. **NOTE:** To exit, un-clip lap belt. **IMPORTANT:** The shoulder belt must pass over your **OUTSIDE** shoulder (in either seat) then diagonally across your chest to the lap belt attach point. Always make sure that seat belts are properly positioned and snug prior to and during entire flight.

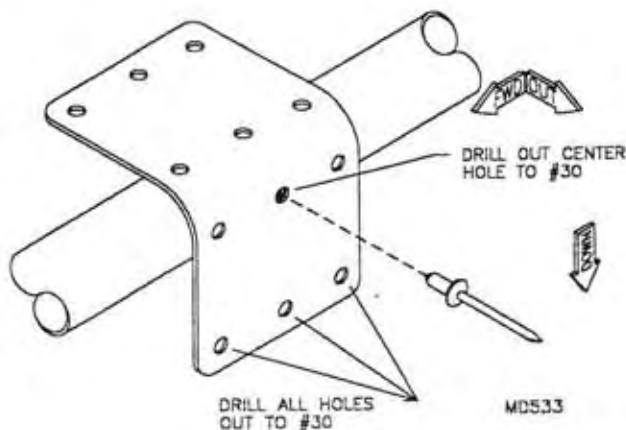
## S-6ES COYOTE II TAIL CONE ASSEMBLY

The tail cone is built of aluminum tubes and unique, stamped gussets that allow tubes in two planes to join, resulting in a light, strong structure. While building, you will pull many stainless steel rivets, so use a high quality pop riveter; air-powered riveters are *very* nice! When setting rivets, be certain holes are clean and rivets set flat against tubes. Pop rivets will not draw the gusset and tube together when pulled! Be certain everything is properly set before pulling; stainless steel rivets are not easy to drill out. **NOTE: Support tail cone with a saw horse between stations 4 and 6 to prevent sagging.**

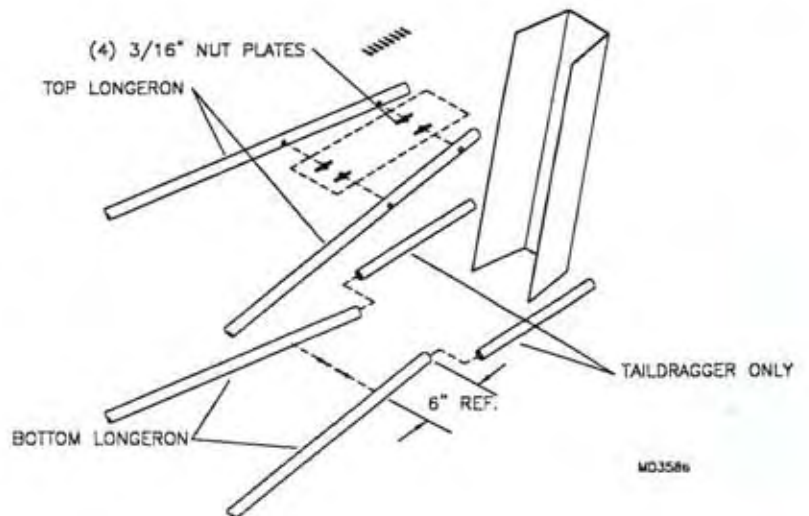
The tailcone can be built for either tricycle or conventional gear; references are made to steps required for completion as a taildragger.

1. Collect all the parts shown on the parts page. Collect the additional parts needed if you are assembling a taildragger model. The fuselage cage should be upright on its gear. Forward end of longerons are marked "F" and have 4 holes at 90 degrees to each other. For your reference, the top longerons are 116 3/4" long and the bottom longerons are 113 3/4". If you are building a taildragger slip the 7/8" doubler tubes into the aft end of each lower longeron. To keep the doublers from sliding out locate a #40 rivet 6" in from the end of the longeron on the top side. Insert the front end of the top and bottom longerons onto the stubs welded to top of the cage. **NOTE: Apply clear silicone liberally to stubs to create a corrosion barrier between fuselage steel and tail cone aluminum.** Turn the longerons so the small pre-drilled holes are in a horizontal position and on the **OUTSIDE**. Insert the longerons on as far as possible and use clamps to hold the top longerons in place. Drill the center hole of the outside gussets to #30 and rivet to the hole in the longeron. See **FIGURE 09-01**. On the top longerons between the S-6 and S-7 are two horizontal holes through the tubes. Drill to #11. This is where the brackets that attach the horizontal stabilizer are bolted. Locate 3/16" nut plates to the inside of each of these holes. See **FIGURE 09-01A**.

**FIGURE 09-01**



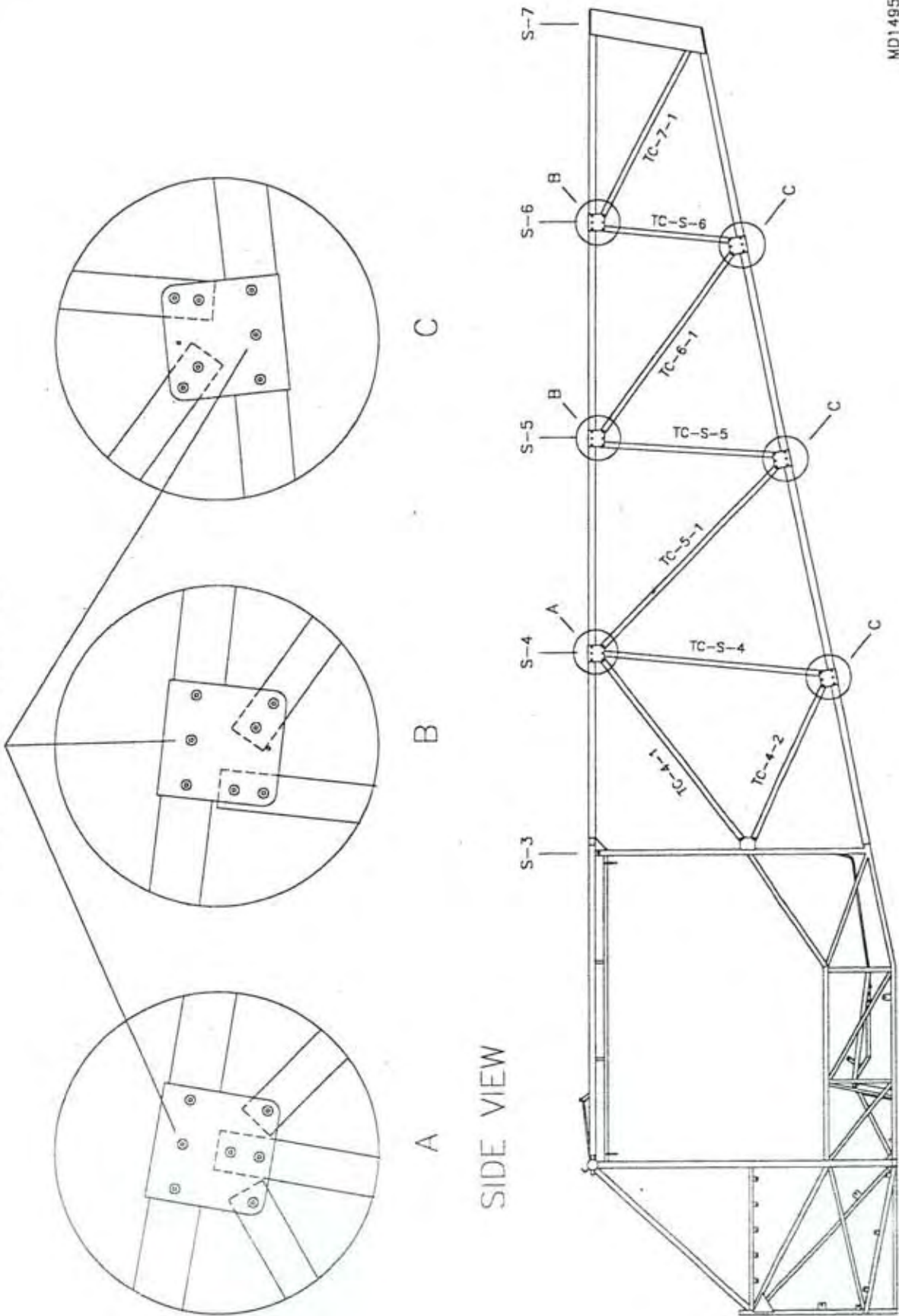
**FIGURE 09-01A**



2. Refer to **FIGURE 09-02** for the side tube location. Drill out the gusset holes to number #30 as shown in **FIGURE 09-01** and cleco the tubes in place to make up the side of the tailcone. Do **NOT** drill and rivet the two forward side diagonals until later (Station 4 upper and lower diagonals). Also, do not rivet, only cleco the Station 6 Side Diagonals in place until the bulkhead is installed. Slip them between the welded tabs midway up on the S-3. After getting one side of the tailcone structure clecoed together and checked out, go ahead and rivet it together. Repeat this step for the other side. The inside cluster gusset will be installed later. Do not install the inside gussets at this time, they will be installed after all the tubes are in place on all four sides of the tailcone.

**FIGURE 09-02**

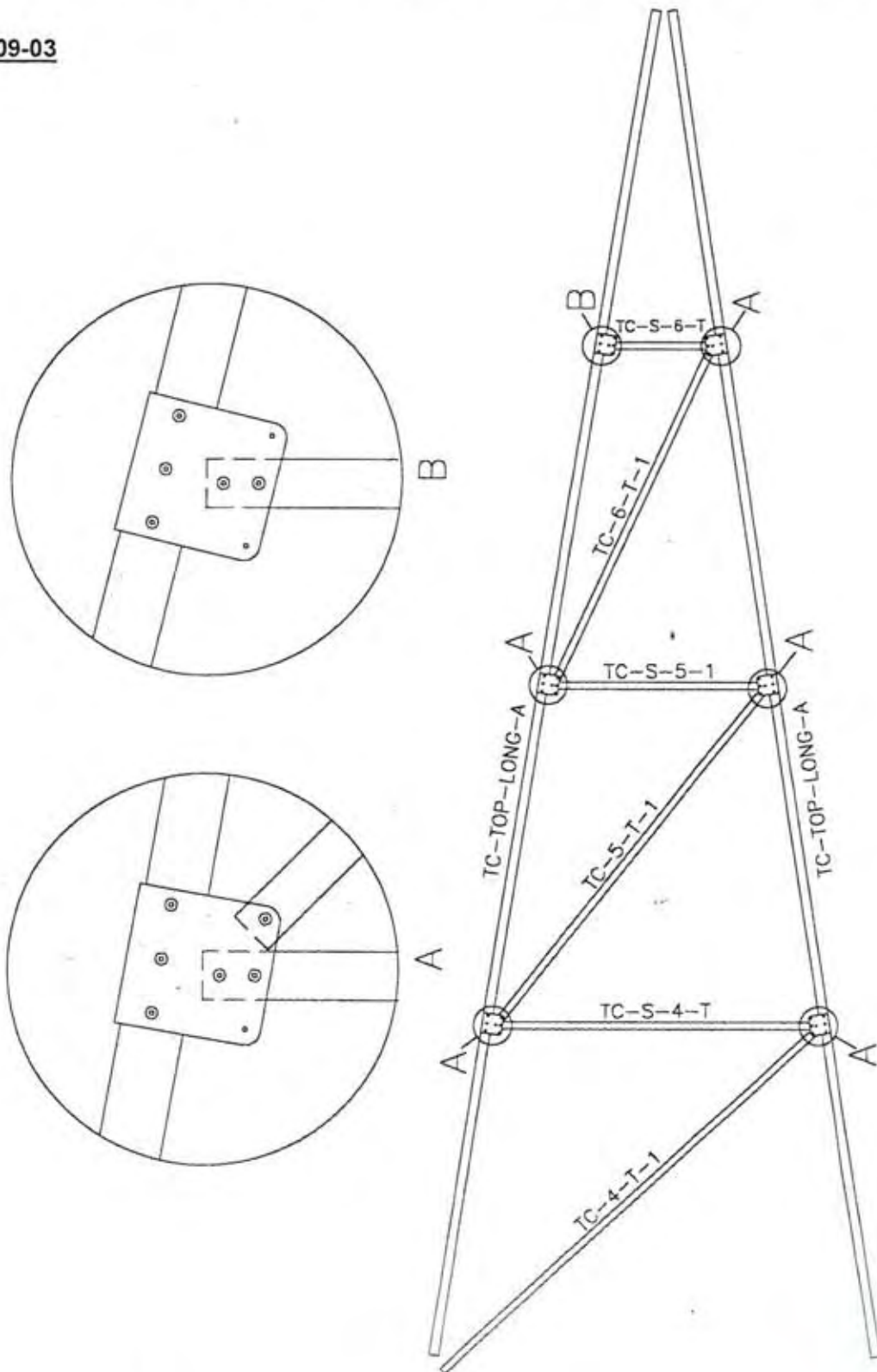
NOTE: ALL GUSSETS LOCATE ON LONGERONS THROUGH CENTER HOLE



MD1495

3. Cleco all the top tubes in place and check for fit before riveting. See **FIGURE 09-03**. Install the Station 4 top diagonal with the holed end into the gusset. Do **NOT** rivet the Station 4 top diagonal at this time. Riveting will be done after the tailcone is squared and riveted to the cockpit cage. Rivet the top tubes once the fit checks out.

**FIGURE 09-03**

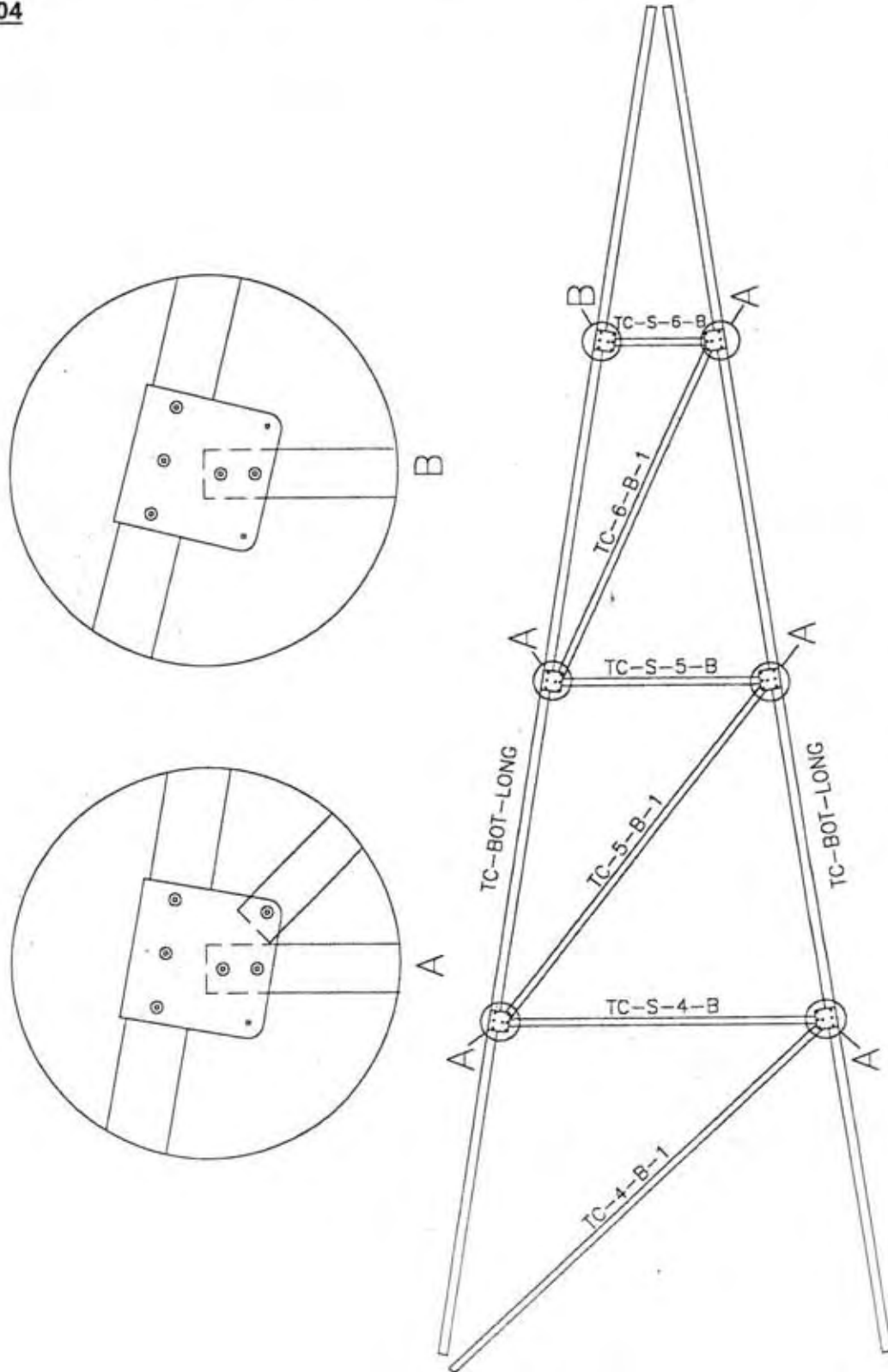


MD3934

TOP LONGERON-TOP VIEW

4. Cleco all the bottom tubes in place and check for fit before riveting. See **FIGURE 09-04**. Install the drilled end of the Station 4 Bottom Diagonal to the gusset and the slotted end over the welded in place web. Do **NOT** rivet this tube until after the tailcone is riveted to the cage. Do **NOT** drill the slotted end at this time. Drill this end after squaring the tailcone. Rivet the bottom tubes once the fit checks out.

**FIGURE 09-04**



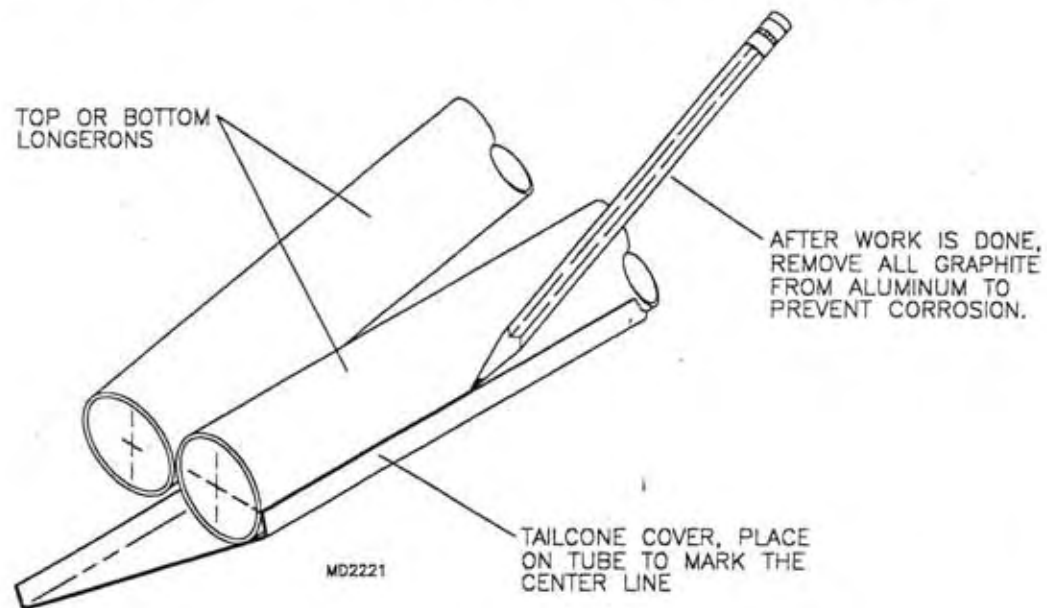
MD3935

BOTTOM LONGERON-TOP VIEW

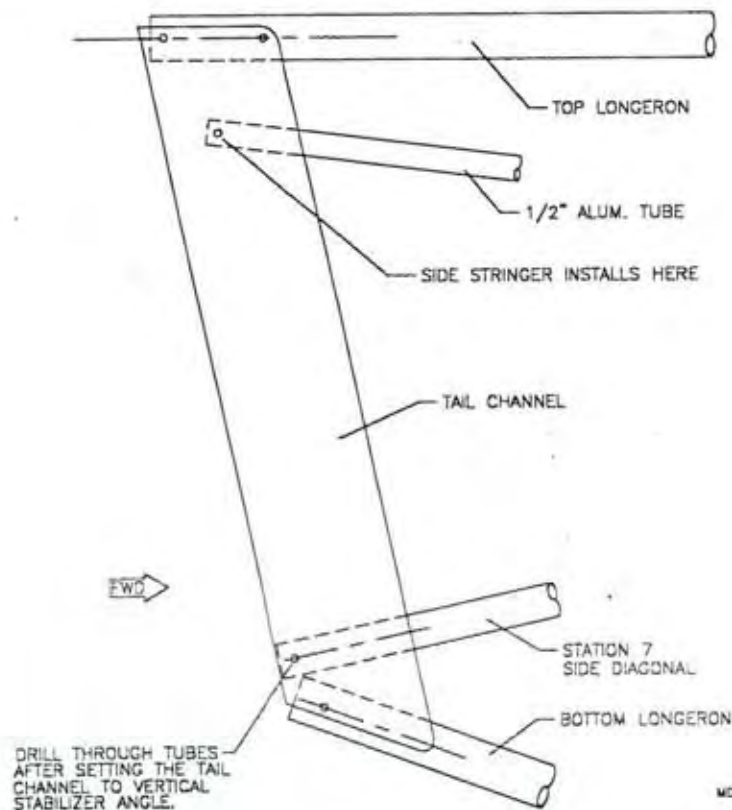


5. Before going any further turn to the TAIL section and assemble the vertical stabilizer frame. The vertical stabilizer frame will be used as an angle gauge to accurately set the tail channel angle. Mark the very tail end of the top and bottom longerons with a pencil line at the tubes halfway point. See **FIGURE 09-05**. This line will serve as a guide to properly locate the holes on the longerons. Slip the tail channel over the ends of the longerons. The top longerons should touch the back of the tail channel and line up on the marks. The tail channel comes pilot drilled. Drill through (#30 drill size) the aft hole on the top of the tail channel and cleco the channel in place. The bottom will be drilled after setting the tail channel to the proper angle. Place the vertical stabilizer assembly in position. The vertical stabilizer spar should rest flat against the tail channel. The front of the stabilizer should touch the Station 6 top crossing tube without forcing. Pivot the channel off the top channel to the longerons at the lower aft locations. Do not rivet on the tail channel, later we will remove the tail channel to install 1/4" nut plates onto the top side of the bottom longerons. See **FIGURE 09-05A**.

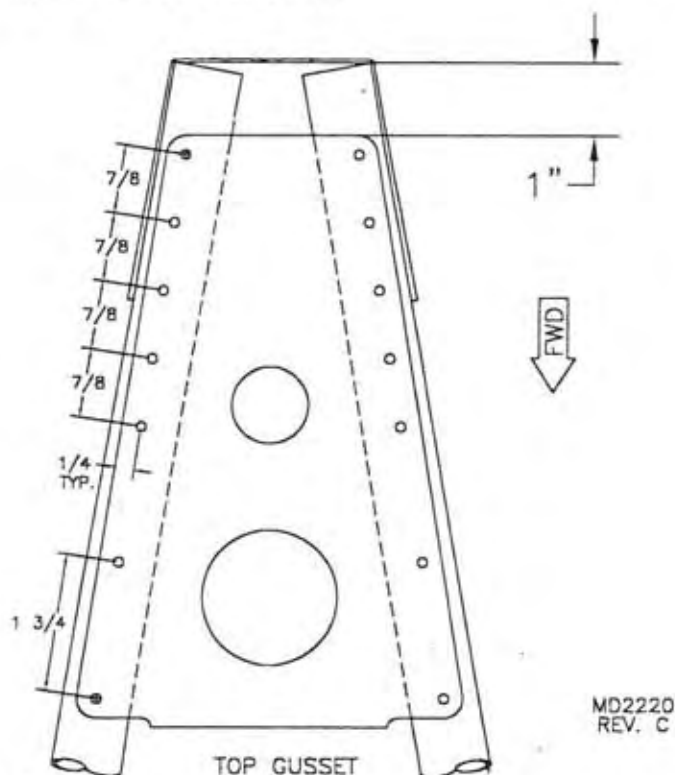
**FIGURE 09-05**



**FIGURE 09-05A**



6. Layout and drill the Tail Cone Upper Gusset as in **FIGURE 09-06**. Locate the upper gusset 1" forward of the ends of the top longerons. **NOTE:** The gusset must clear the Vertical Stabilizer Spar. Drill #30 on the longeron centerline, Cleco, deburr and rivet.

**FIGURE 09-06**

7. **FOR TRIKE MODELS ONLY** – Drill the tail cone bottom gusset as in **FIGURE 07-07**. Locate the 1/4" holes of the lower cable tang 1 1/8" from the ends of the bottom longerons. Center the 1/4" holes on the longerons. Drill the bottom longerons 1/4". Keep the holes squared to the tubes by using a block of wood drilled 1/4" in a drill press as a guide. See **FIGURE 07-07A**. Locate the bottom gusset against the aft side of the tail channel. Bend the gusset as needed to match the tail channel and longeron angle. Drill #30 and cleco. Remove the tail channel, transfer drill 1/4" the bottom gusset. Rivet 1/4" nut plates to the top of the bottom longerons. Install the tail channel and rivet the longerons, gussets, and side diagonals.

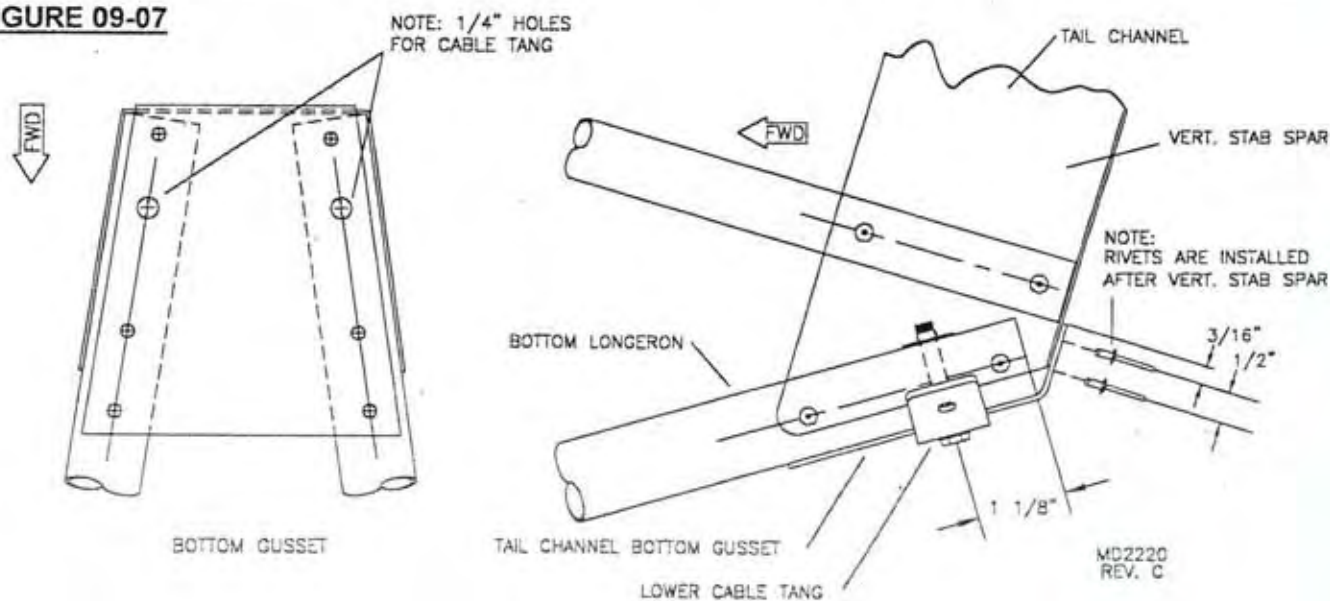
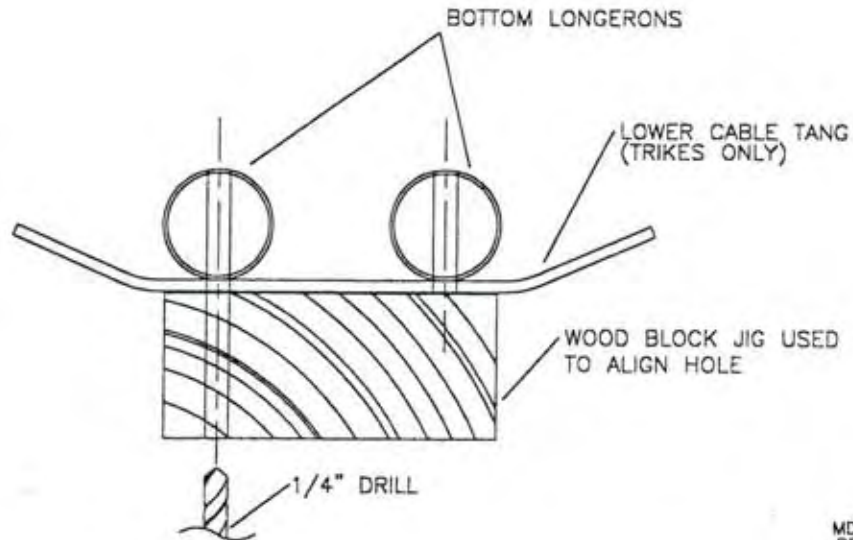
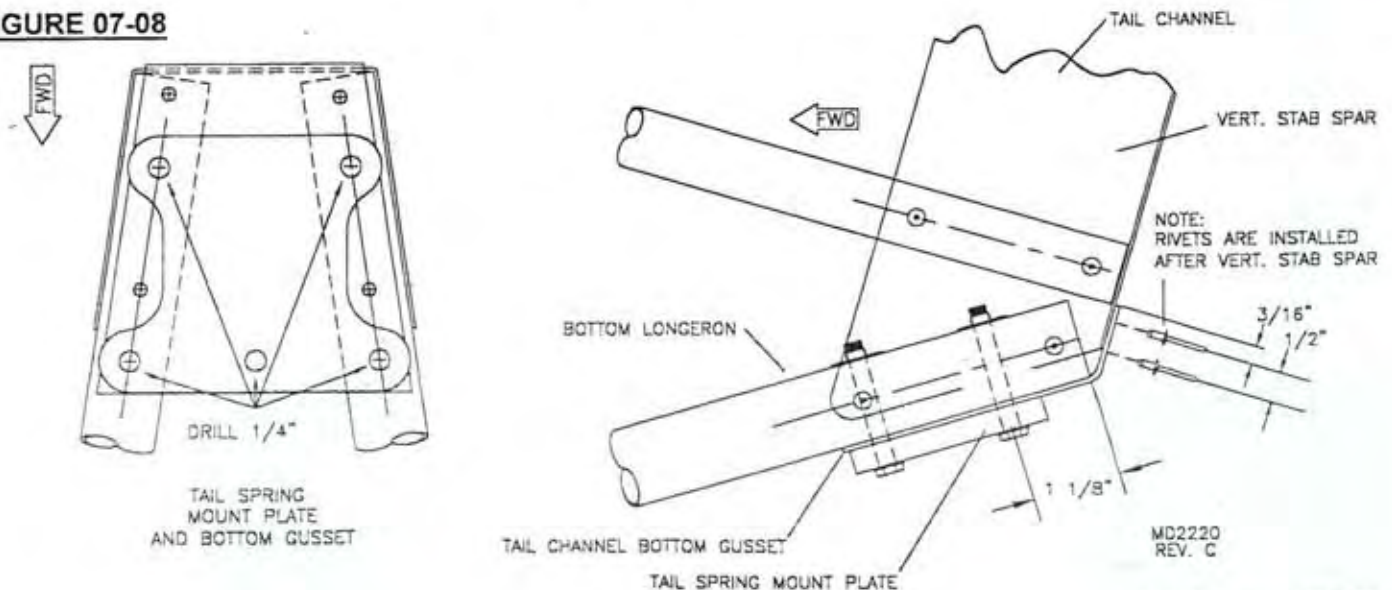
**FIGURE 09-07**

FIGURE 07-07A

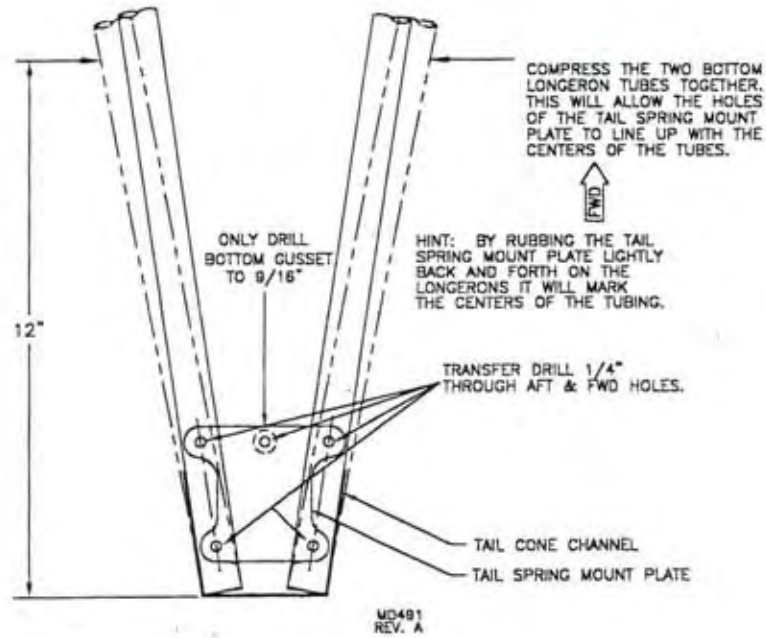
MD2220  
REV. C

8. **FOR TAILDRAGGER MODELS ONLY** – Drill the tail cone bottom gusset as in **FIGURE 07-08**. Locate the aft  $1/4$ " holes of the tail spring mount plate  $1\ 1/8$ " from the ends of the bottom longerons. Center the  $1/4$ " holes on the longeron. Drill the bottom longerons  $1/4$ ". Keep the holes squared to the tubes by using a block of wood drilled  $1/4$ " in a drill press as a guide. Refer back to **FIGURE 07-07A**. Pinch bottom longerons together if plate's holes do not fall on longeron centerlines. See **FIGURE 07-08A**. **NOTE: Transfer drill and cleco bottom gusset between mount plate and longerons.** Retain bottom gusset to longerons with four (4) rivets. Bend the gusset as needed to match the tail channel and longeron angle. Transfer drill  $1/4$ " though Tail Spring Mount Plate fwd center hole. Remove Mount Plate and drill this hole to  $9/16$ " to clear tail spring tensile nut. Remove tail channel and rivet  $1/4$ " nut plates to top of bottom longerons. Fabricate four (4)  $3/8$ " x  $3/4$ " bushings to fit vertically inside doublers for reinforcement. Safety wire wrapped around bushings aids insertion; apply JB Weld epoxy to bushing edges to fix in place. Retain with bolts until set (wax or lightly grease bolts to keep them from binding). After glue sets and gussets are installed, remove bolts and install them through plate, gusset and longerons. Cleco tail channel back onto longerons and bolt tail spring mount plate to longerons. Slip Side Gusset Plates under tail channel so it laps under  $3/4$ ". **HINT: The aft lower end of the Side Gusset Plates will be flush with the bottom of the tail channel.** Drill through remaining holes in channel and locate the others as shown in **FIGURE 07-08B**. After tailcone is aligned, rivet gusset in place on **OUTSIDE** of tail channel. **FIGURE 07-08B** also shows the assembly with tail spring mount plate.

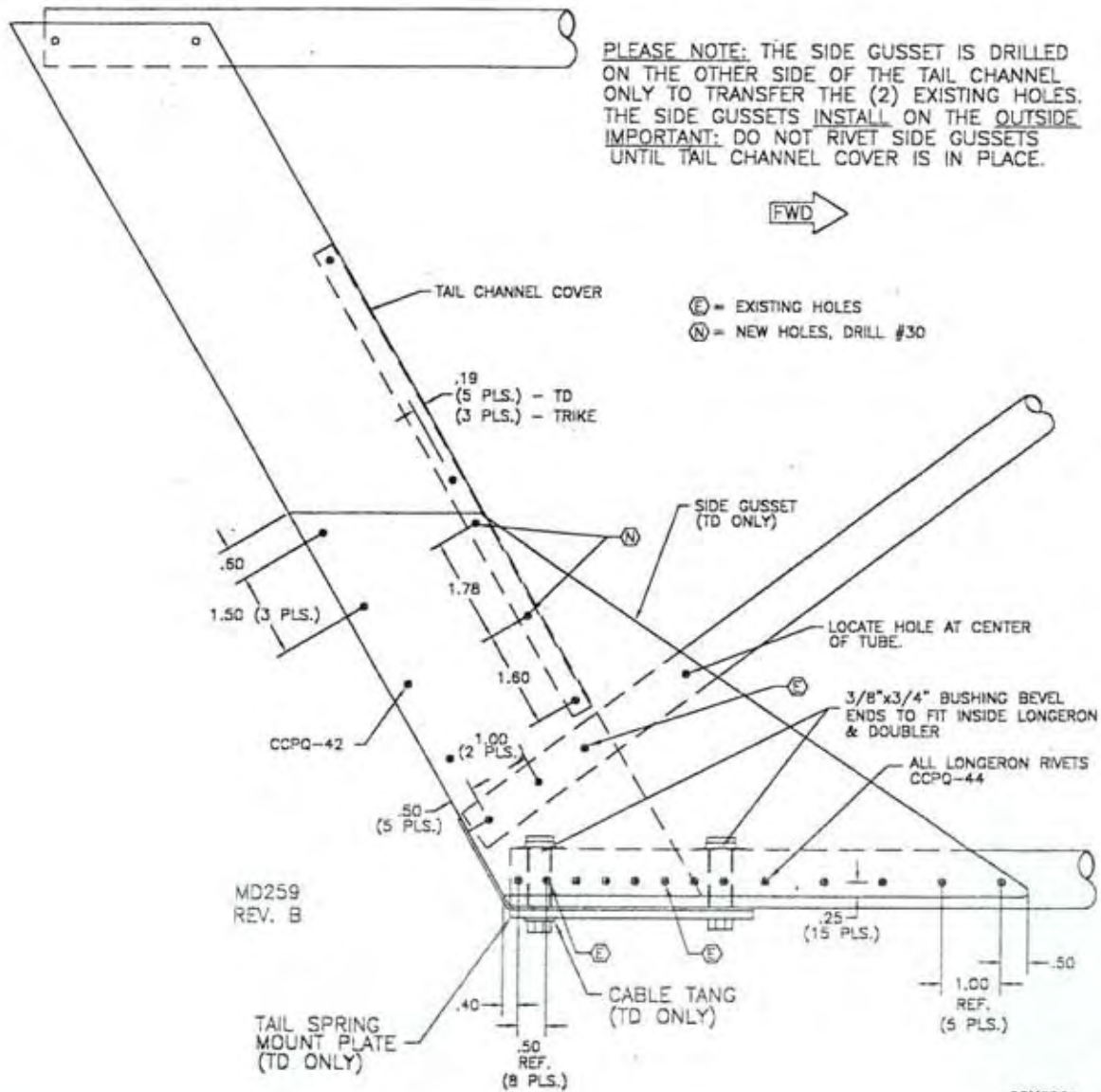
FIGURE 07-08

MD2220  
REV. C

**FIGURE 07-08A**

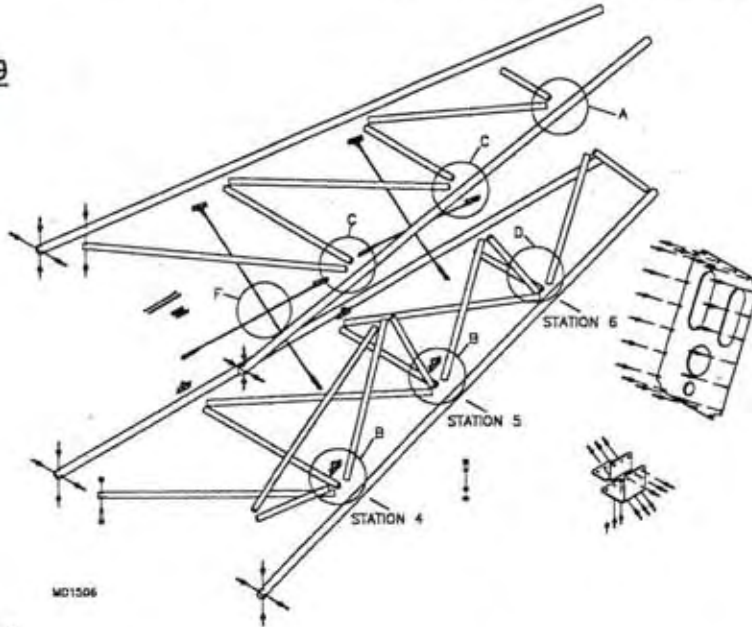


**FIGURE 07-08B**

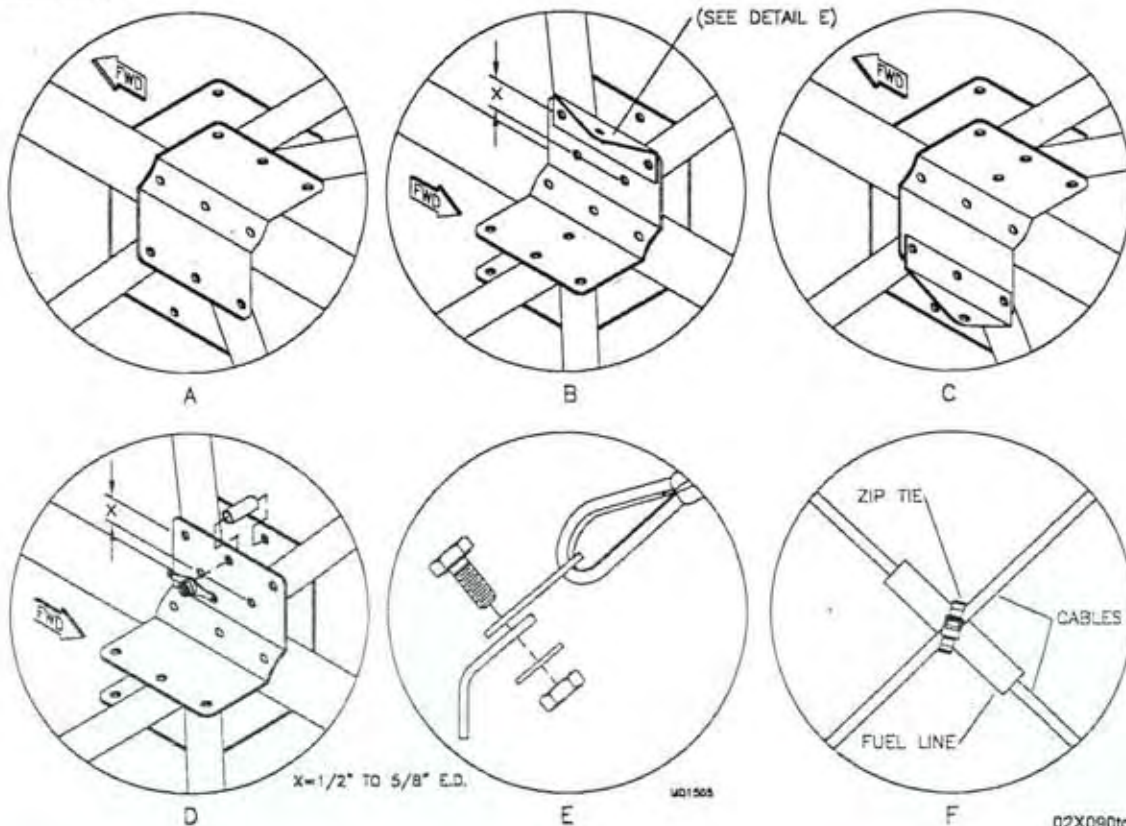


9. Install inside cluster gussets. Be sure the gusset holes line up on tube centerlines. When riveting side tubes, you will install Station 4 and 5 diagonal cables and cable attachment pieces. **IMPORTANT:** *Cleco cable attachments at this time. Rivet only after installing second rivets in tailcone tubes as instructed later.* Drill the inboard hole of the lower cable attachments to #11. Use the longer 1/4" (CCPQ-44) grip where these rivet into tubes and the 1/8" (CCPQ-42) grip rivet where they attach to gussets only. Do not connect cables yet; wait until tailcone is aligned. Square the tailcone, measuring diagonally inside the tailcone. Use ratchet straps to temporarily hold the tailcone square. Install the Station 6 bulkhead. Refer to **FIGURE 07-09** and **FIGURE 07-09A** detail drawings for which holes to leave open. Detail "D" shows a 3/16" nut plate and bushing installed to middle hole of lower cluster at Station 6; this is the forward lower cable attach point. JB Weld epoxy bushing in place; hold with a waxed bolt while epoxy sets. **HINT:** *Drill each middle hole #11 and use a 3/16" bolt to align the inside gusset for riveting.* Drill #30 and cleco the tail channel cover to the tail channel. Refer to **FIGURE 07-08B**.

**FIGURE 07-09**

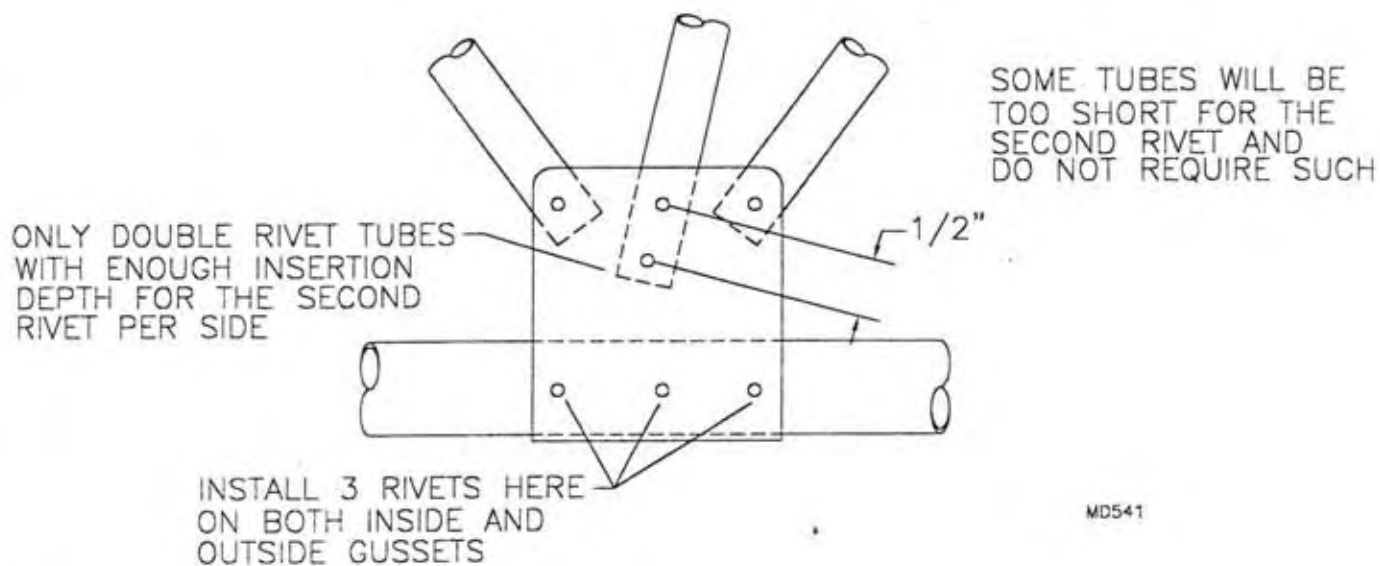


**FIGURE 07-09A**

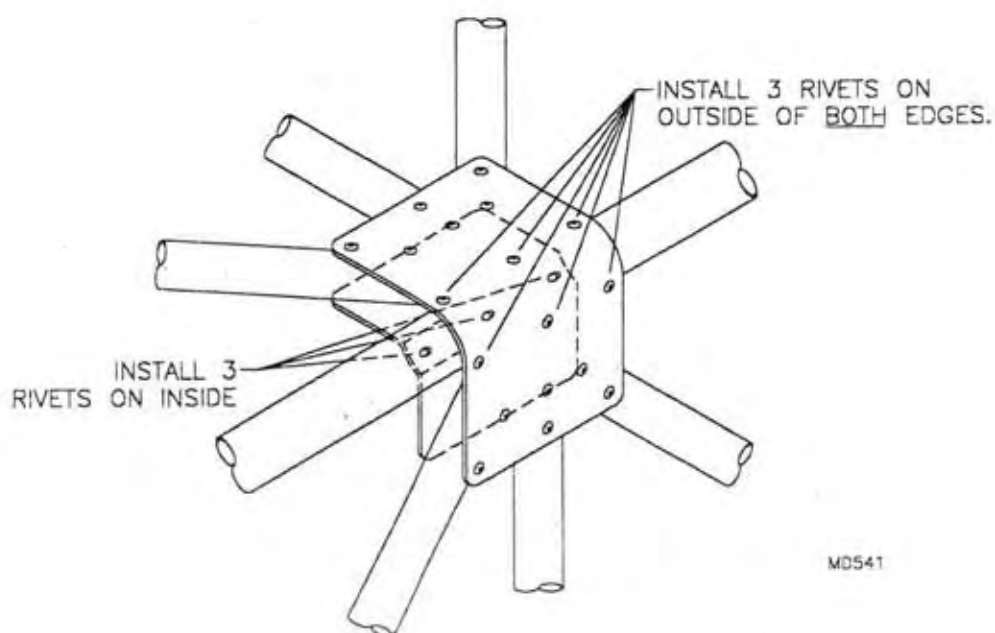


10. Install all second rivets in ends of the 3/4" tubes. Refer to **FIGURE 07-10**. **NOTE:** Most tubes require double rivets on each end, totaling 4 rivets per end; however, Station 4 and 5 side diagonals attach with only two to top cluster. Install six rivets to attach the outside of the gussets to the longerons. Install three rivets on inside gusset. See **FIGURE 07-10** and **FIGURE 07-10A**. Rivet cable attachments and connect cables.

**FIGURE 07-10**

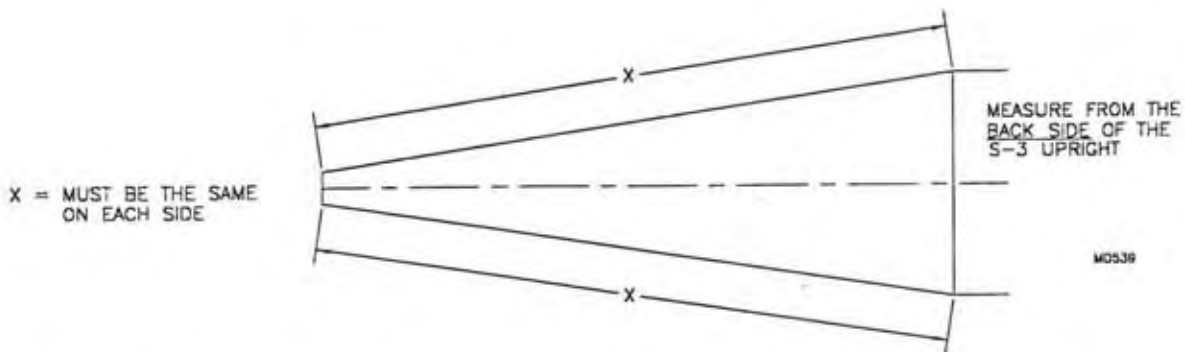


**FIGURE 07-10A**



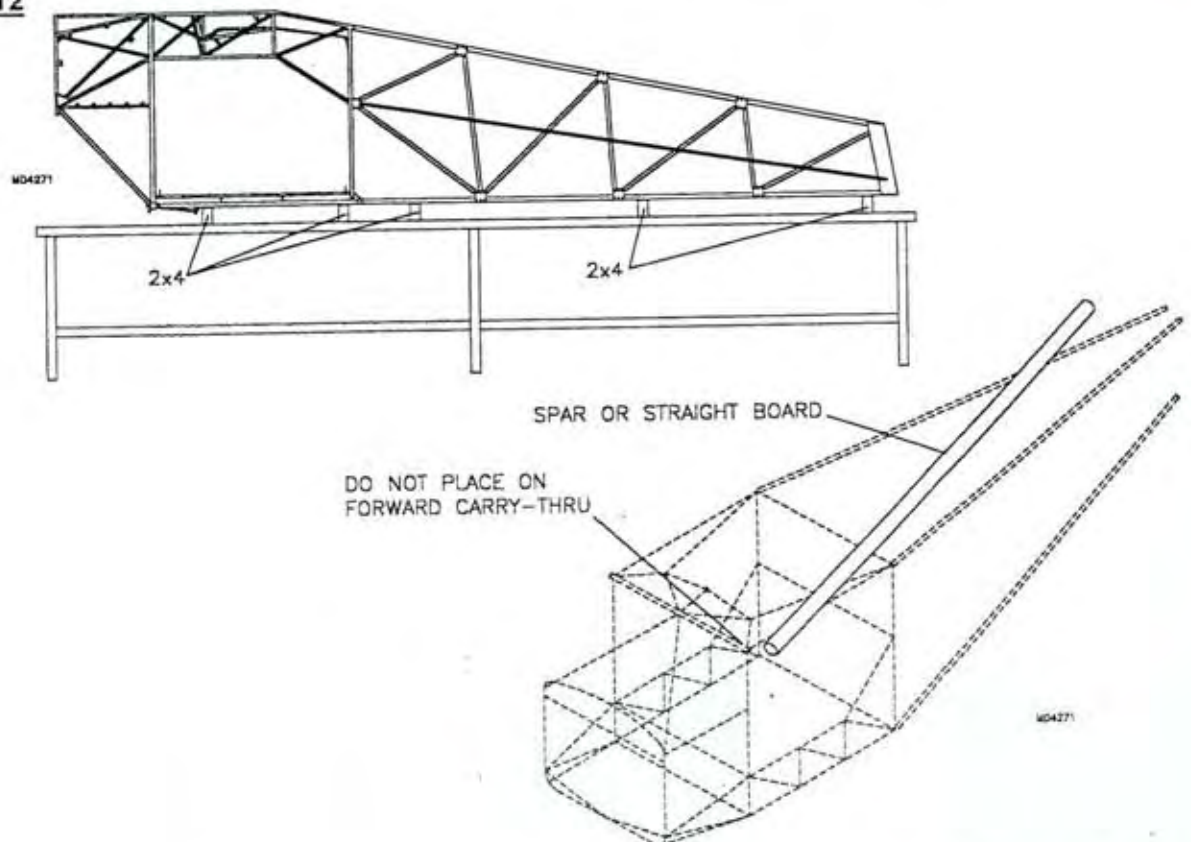
11. Check for perfect alignment of the four longerons to the cage. **Note:** Apply a generous amount of clear silicon to the fuselage stubs to prevent corrosion in this joint. Smooth the excess out to create a corrosion barrier between the fuselage and the tailcone. The tailcone should have the same side to side measurement to assure symmetry. See **FIGURE 09-11**. Once the side to side measures are set clamp the top longerons in place. **HINT:** Place a mark on top longerons where they install into stubs. This will help indicate if the longerons have moved during the next step.

**FIGURE 09-11**

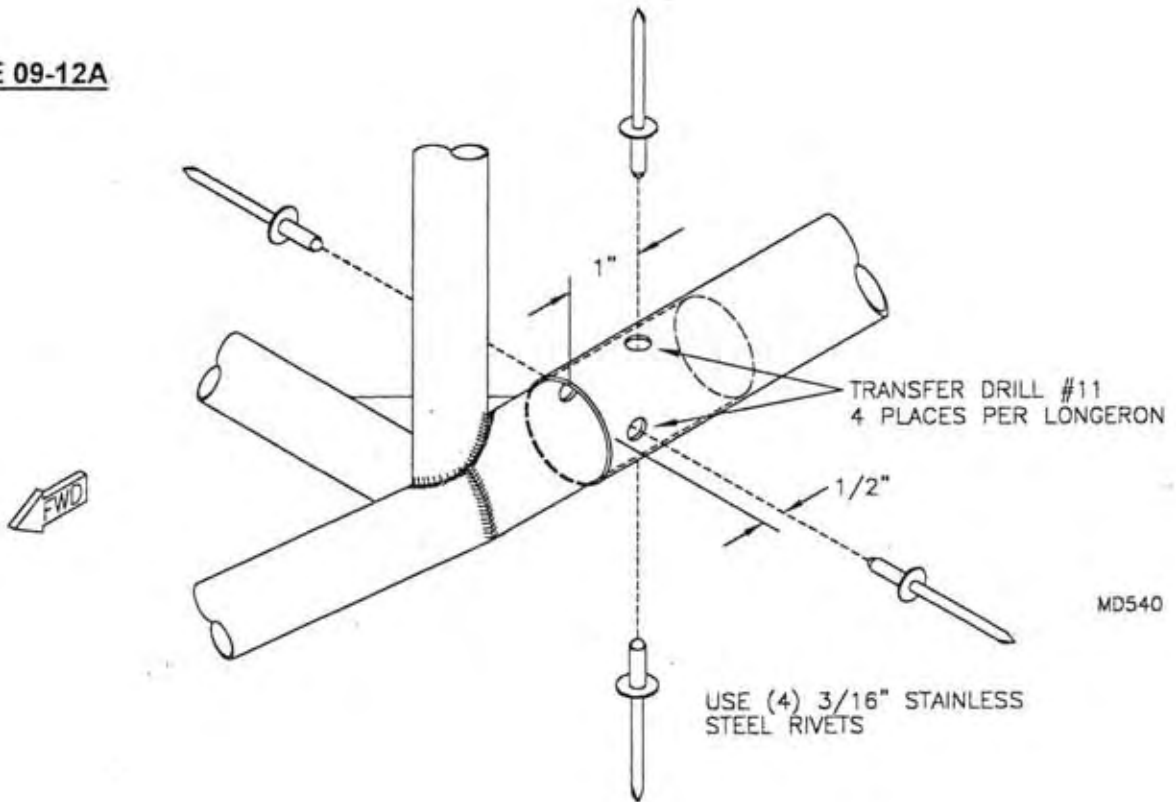


12. The tailcone should line up straight with top longerons of the cabin structure. One method is to lay a straight board or leading edge spar across the cabin top longerons and top of S-3 carry-thru. See **FIGURE 09-12**. Another way is to lay the cage upside down on a flat table on top of 2 x 4 boards. **NOTE:** Be sure the boards are only under the top longerons and Station 3 carry-thru. Once the side to side and top alignments are set, drill and rivet as in **FIGURE 09-12A**.

**FIGURE 09-12**

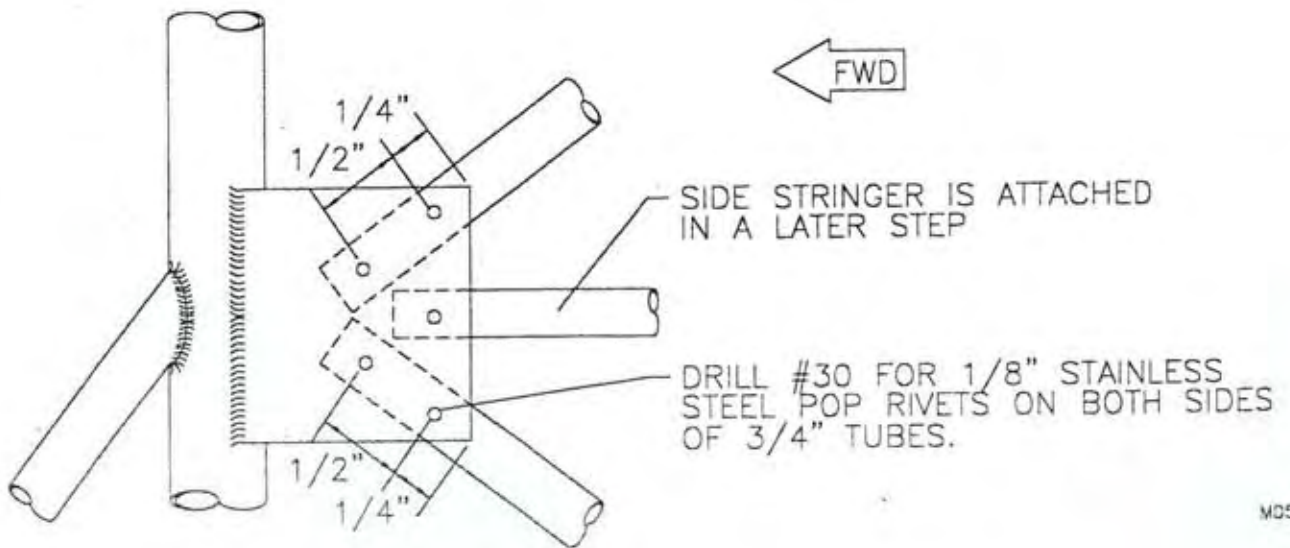


**FIGURE 09-12A**



13. With the tail cone riveted to the cage, the top and bottom Station 4 diagonals may be riveted. The top one attaches between the welded tabs on the upper right hand corner. Slip the tube between the tabs and drill and rivet with #11 stainless steel rivets. The bottom tube is slotted and slips over the gusset welded in the lower right hand corner. Drill through the gusset using the tube as a guide. Bolt from the bottom. The Station 4 side and side lower diagonals can now be riveted in place. See **FIGURE 09-13** for details.

**FIGURE 09-13**

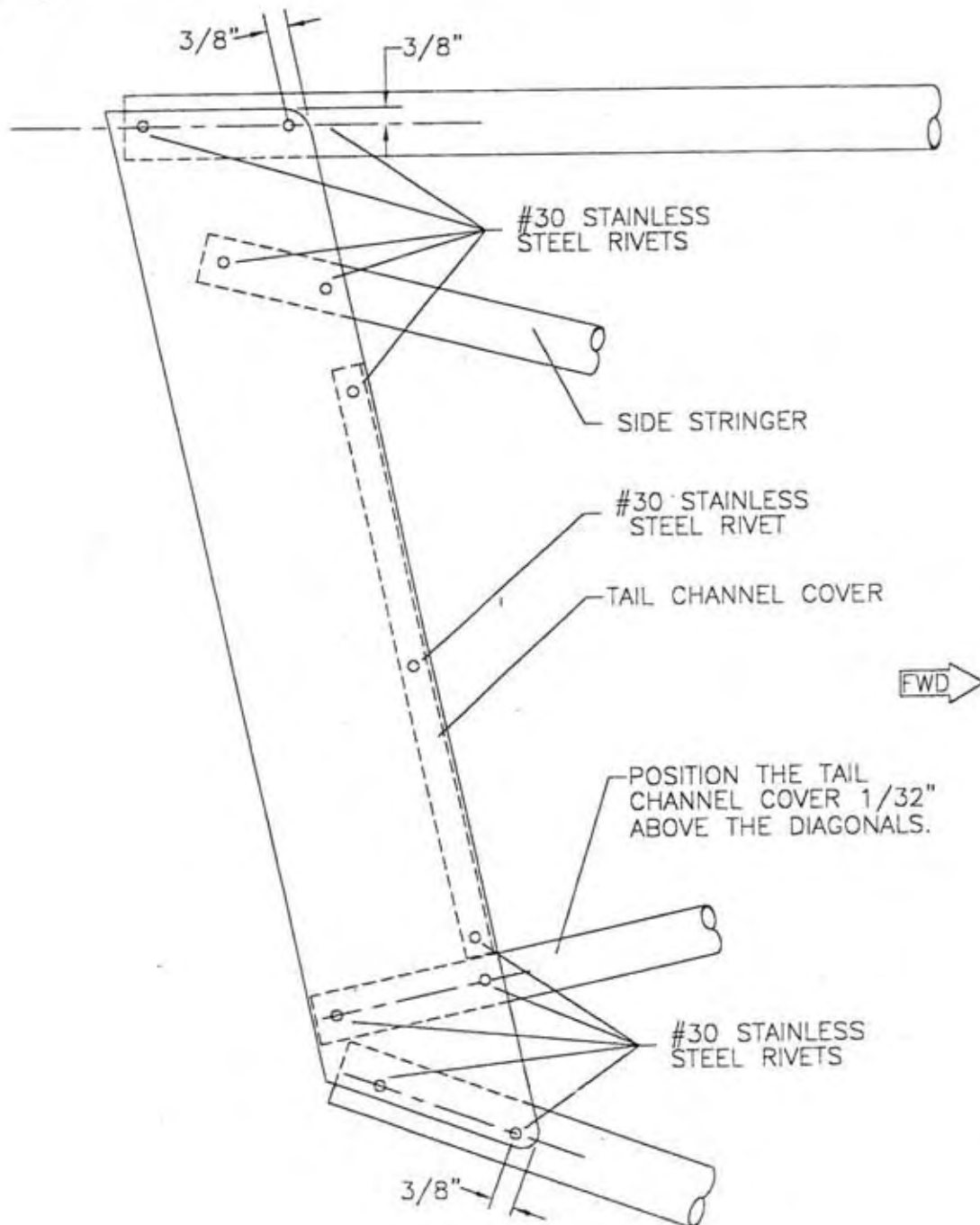


MD541



14. Locate and final rivet the tail channel as shown in **FIGURE 09-14**. Attach forward ends of side stringers inside welded tabs at Station 3 and retain as depicted in **FIGURE 09-14A**. Make sure the side stringers are level and rivet aft end to the tail channel. Retain the middle of the side stringers with safety wire around the Station 5 side tube. See **FIGURE 09-14A**. Make sure the side stringers are in a level position before covering.

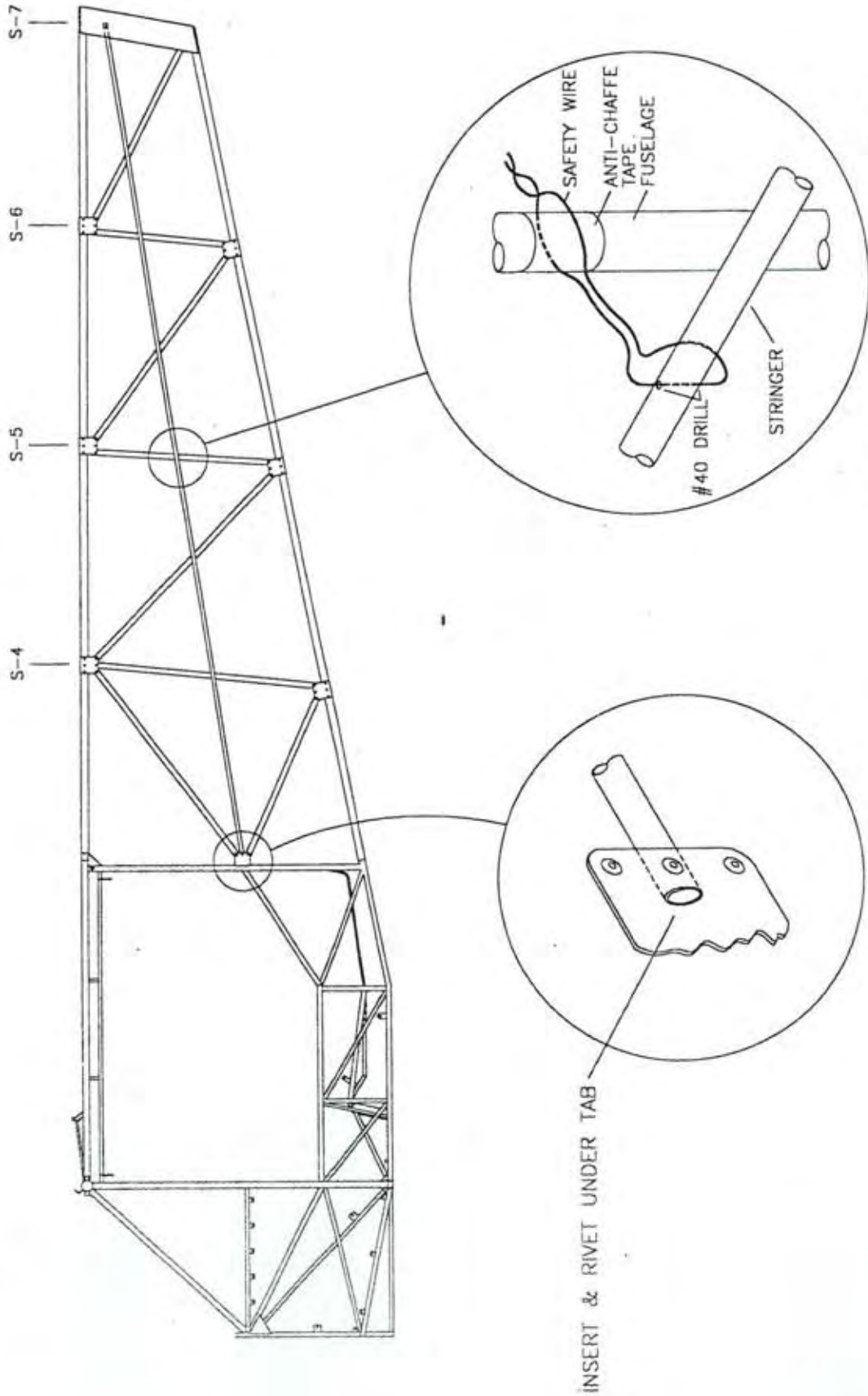
**FIGURE 09-014**



MD542

FIGURE 09-14A

MD1984

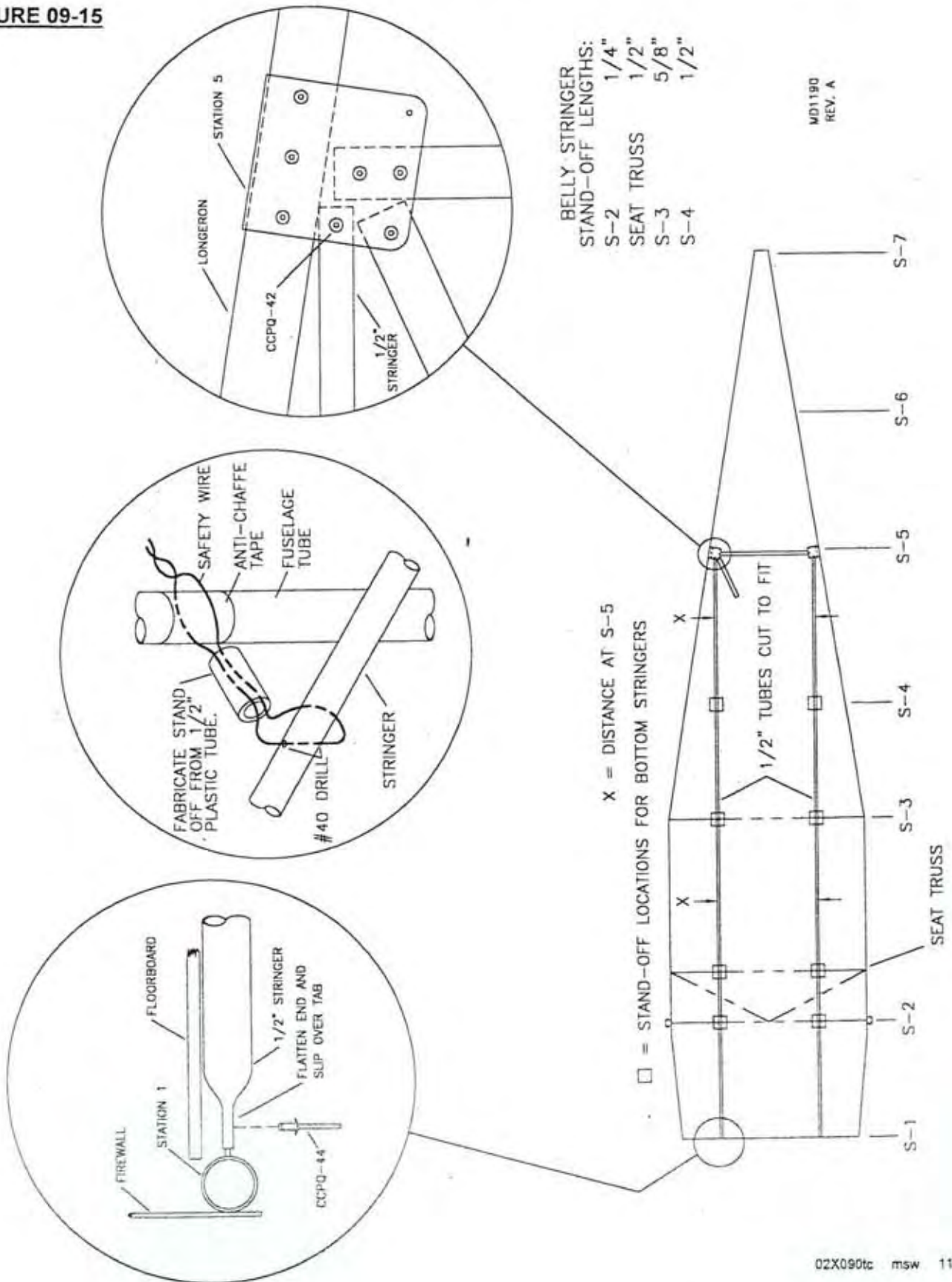


STRINGER DETAIL FROM OUTSIDE OF CAGE

SIDE STRINGER DETAIL

15. Cut Bottom Stringers to length, flatten forward ends and slip over Station 1 tabs, drill #30 and rivet. See FIGURE 09-15 Trim aft end of stringer to clear bottom crossing tube. Install bottom stringers with stand-offs, per FIGURE 09-15. Be certain stringers are straight and have stand offs in place, before covering.

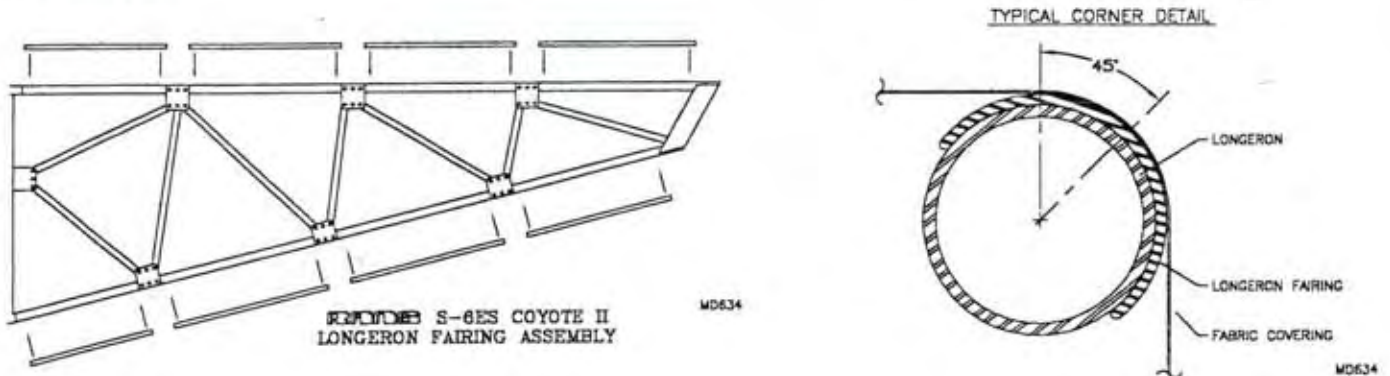
**FIGURE 09-15**



16. The top stringer has both ends crimped, however, one end is crimped closed and the other is slightly open. The top stringer attaches by inserting the partially flattened end into the forward tab on the cage. Rivet the other end to the Station 6 top diagonal. Make sure the top stringer is running straight down the middle before riveting.

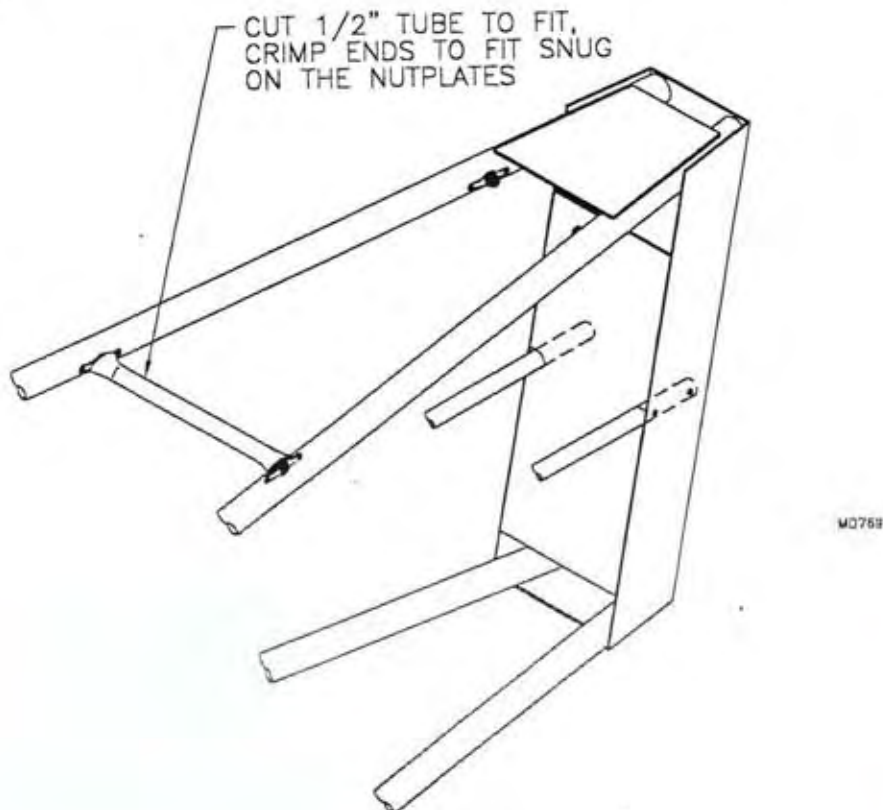
17. Cut the longeron fairing material to fit between the clusters, debur and snap in place as per **FIGURE 09-17**. Locate the holes for the horizontal stabilizer attachment under the fairing material and drill through the fairing material.

**FIGURE 09-17**



18. Measure the distance between the two forward nut plates used to retain the forward horizontal stabilizer brackets. Cut and fit a 1/2" aluminum tube to fit between these nut plates. Crimp the ends to keep tube tight against the nut plates. See **FIGURE 09-18**. At this point, the tailcone should be fully assembled. Check the structure carefully before covering for placement of all rivets. Please note the rudder cable guides will need to be installed before covering (See Rudder).

**FIGURE 09-18**



## S-6ES COYOTE II - DOOR ASSEMBLY

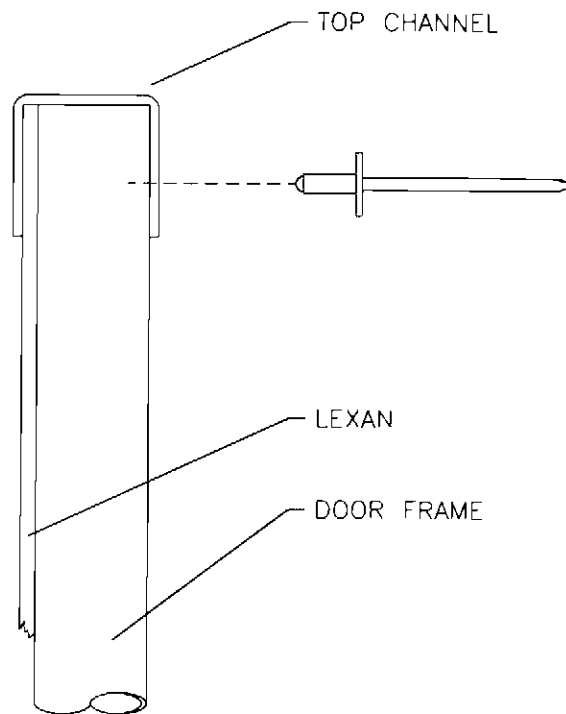
### LEXAN INSTALLATION

**\*NOTE:** The windshield needs to be installed to final install the doors.

**IMPORTANT:** Install the Aluminum Door Doubler inside the Door Frame before riveting.  
See 010B – Hydraulic Door Lift Installation.

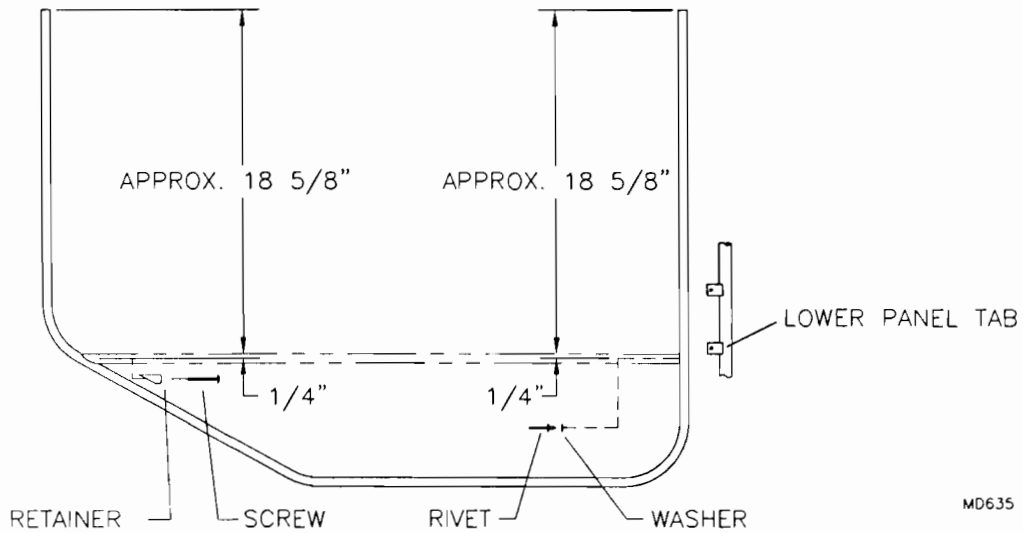
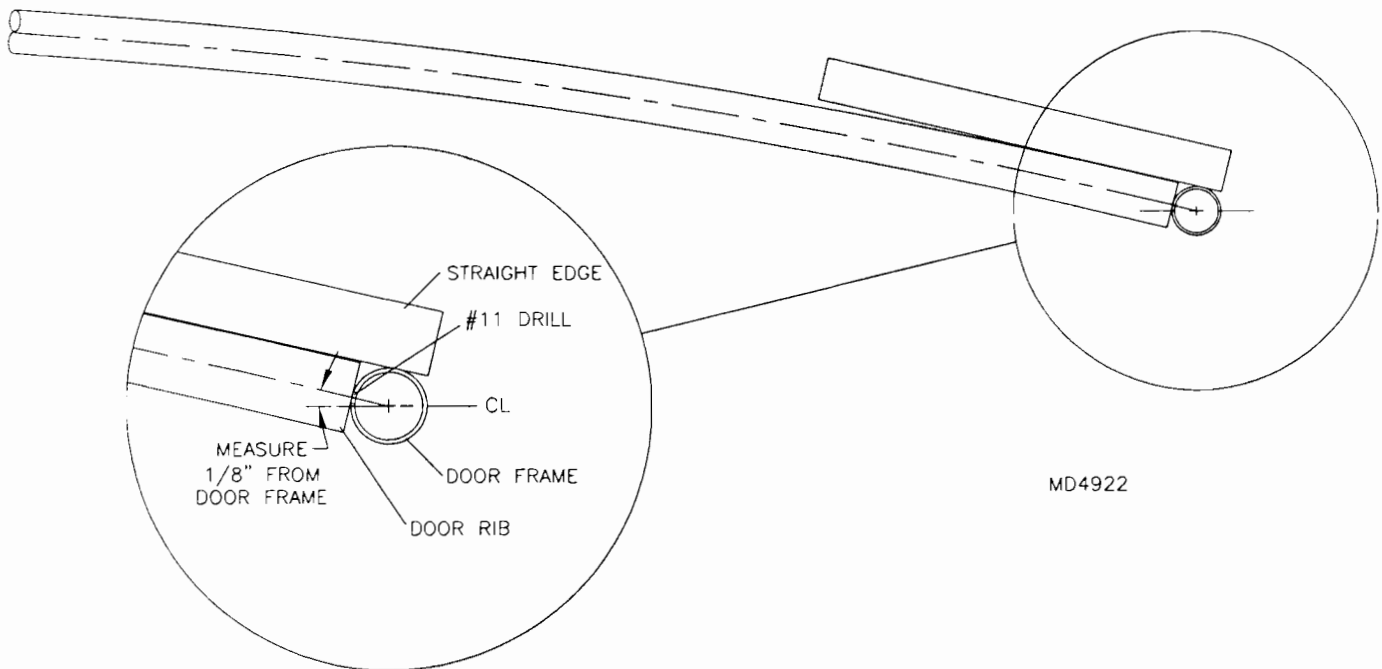
1. Temporarily bolt the door frame in place on the fuselage. Place the Door Top Channel over the top of the frame. Drill #30 on centerline. See **FIGURE 010-01**. Rivet the channel on the inside to the frame with 1/8" stainless steel pop rivets. **IMPORTANT:** The use of the stainless steel pop rivets in the assembly of the doors is very specific. Use them only in the places called for. Locate and drill a hole on the outboard side of the channel centered on the frame.

**FIGURE 010-01**

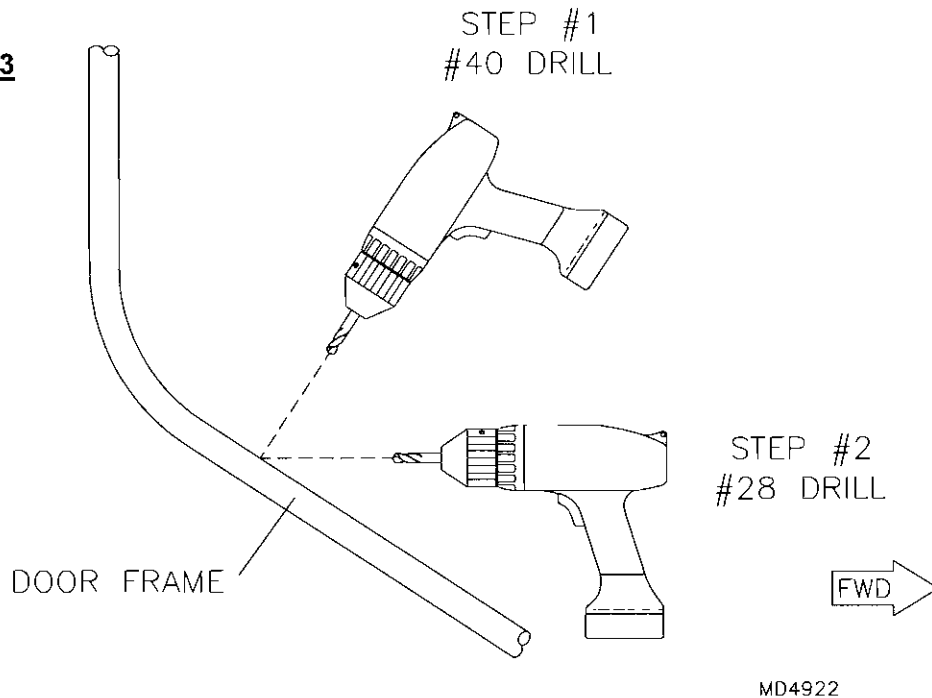


MD515

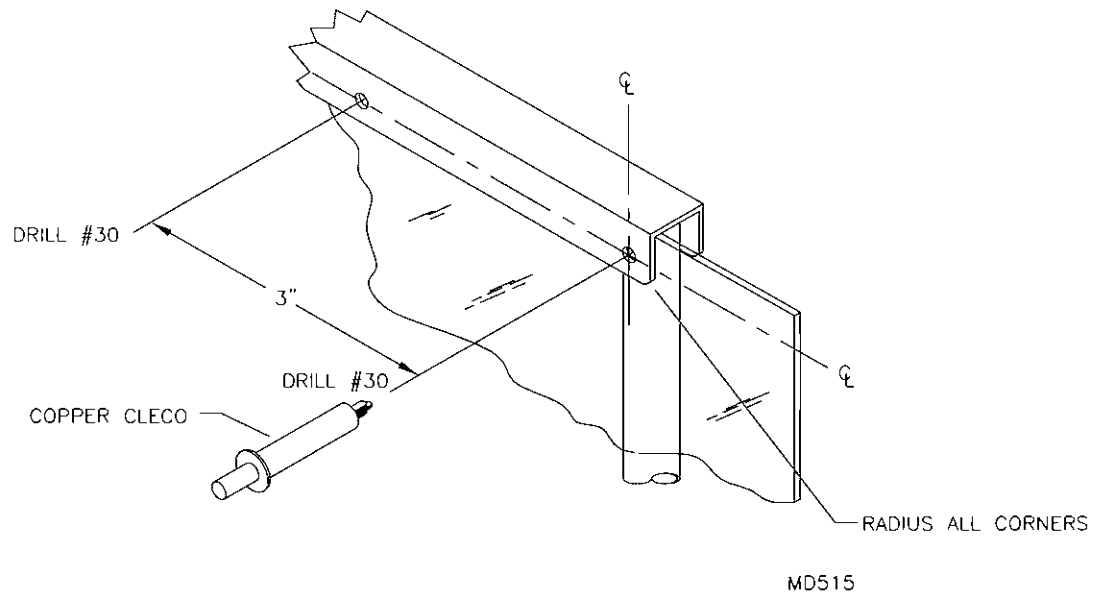
2. Locate the top of the door rib flush with the bottom of the instrument panel bottom tab and mark on the door frame. See **FIGURE 010-02**. This line will represent the top of the door rib. Measure down 1/4" from this mark and put a mark on the inside of the tube in line with the top hinge hole. This will represent the centerline of the door rib. Remove the door assembly from the fuselage. Place on a flat table or sawhorses. Refer to **FIGURE 010-02A** and drill a #11 hole at this point and install a button. **NOTE:** A button is a 3/16" aluminum rivet with a 3/16" thick washer underneath it. The button is used to retain the door rib to the door frame.

**FIGURE 010-02****FIGURE 010-02A**

3. To locate the Door Rib Retainer, measure down the same amount as determined by the Fwd button. Mark the location and drill according to **FIGURE 010-03**.

**FIGURE 010-03**

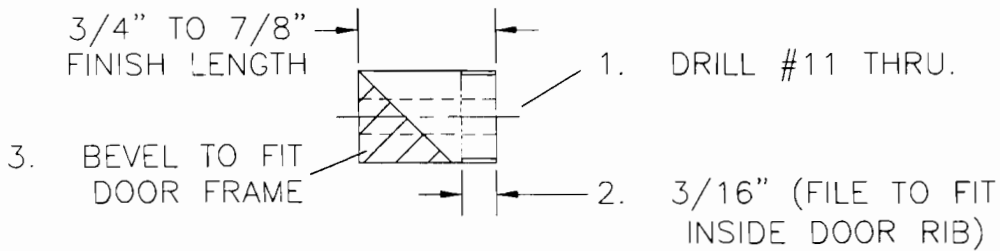
4. Radius each corner of the Top Channel. Mark off the hole locations on the top channel every 3", starting from the front and drill #30. See **FIGURE 010-04**.

**FIGURE 010-04**

5. Clamp the Upper Door Lexan so the top edge is flush with the frame top (between Top Channel and Door Frame). Center the Lexan fwd and aft on the Door Frame. **IMPORTANT: Do NOT remove the protective plastic film until ready to rivet.** Transfer drill #30 through the previously drilled holes in the channel and Cleco. The Lexan should be tight against the channel. **HINT: Use a block of wood pressed up into the top channel to back up the channel and Lexan while drilling.** Remove the Lexan from the frame.

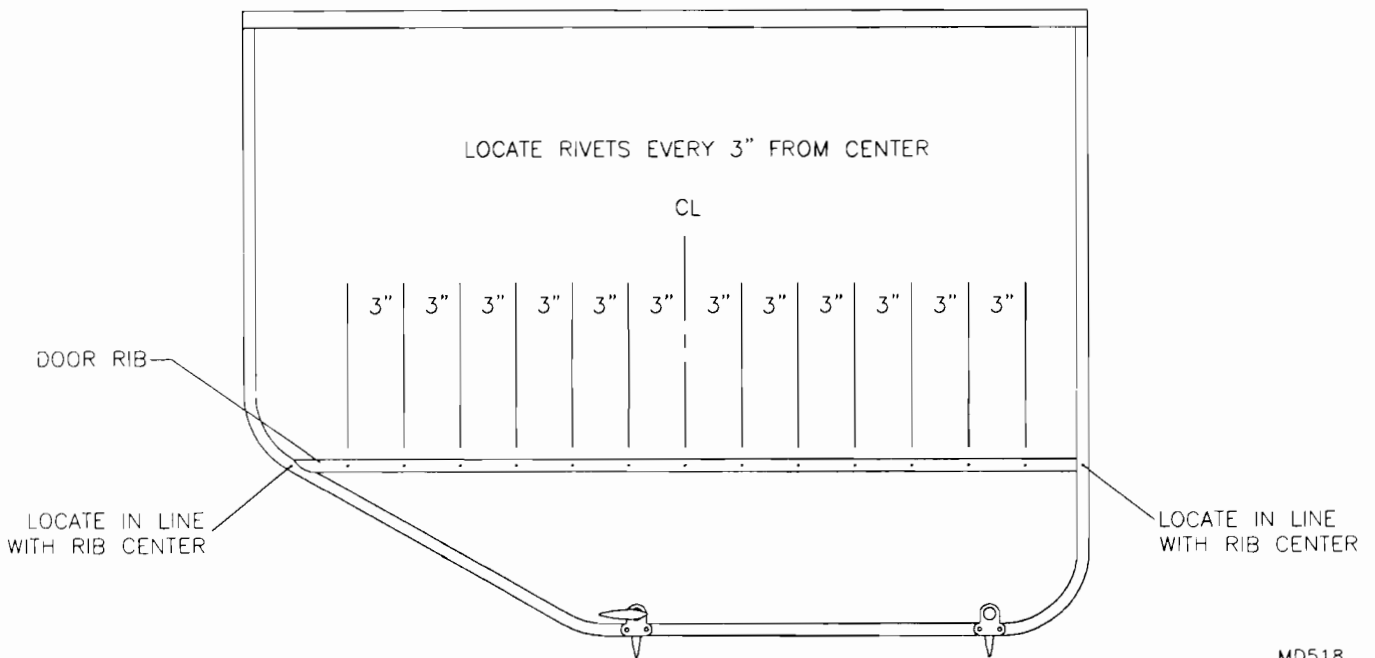
6. Cut the Door Rib Retainer material into 1" lengths. **NOTE:** 2 retainers are required. Extra material is included for errors. Refer to **FIGURE 010-06** and shape the retainer. **HINT:** Chuck the Rib Retainer into a drill press, sand to fit inside the Door Rib. Use a Dremel with 1/2" sanding drum to shape the aft end. Install the Rib Retainer to the Door Frame. Push the rib over the retainer. Be sure the rib curves upward, 90° to the door frame. Trim the fwd end of the rib to snap over the fwd button. **IMPORTANT:** Do **NOT** change the curvature of the rib. Mark the top centerline of the rib. Locate and drill #30 holes per **FIGURE 010-06A**.

**FIGURE 010-06**



MD4922

**FIGURE 010-06A**

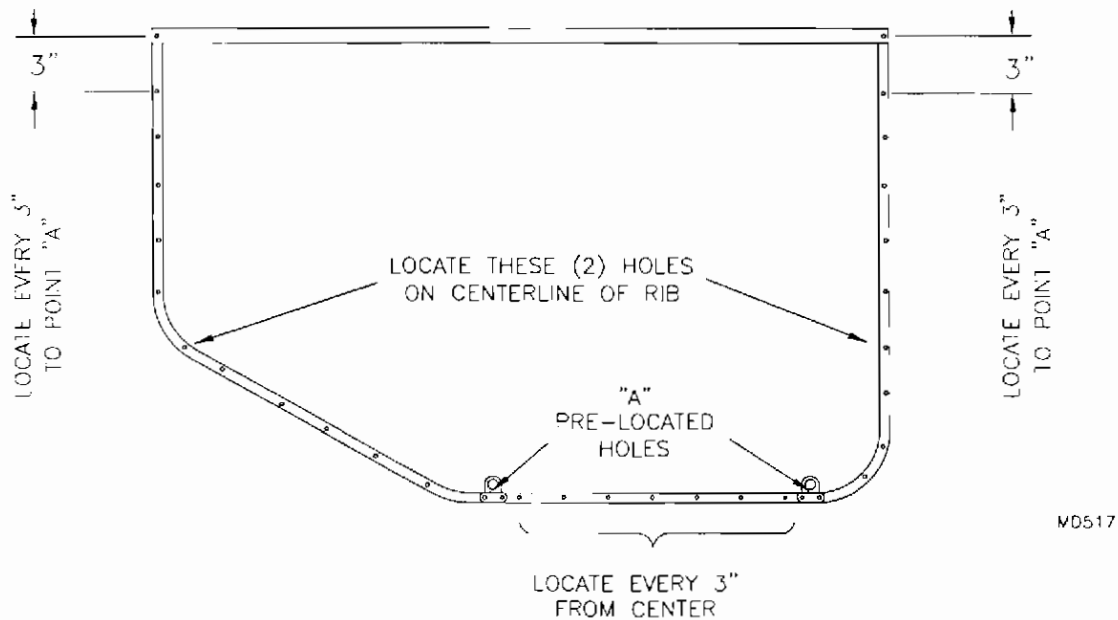


MD518



7. Drill #30 holes every 3" along the center of the door frame as shown in **FIGURE 010-07** and deburr. The pre-drilled holes in the door frame near "A" is for the door handle gussets.

**FIGURE 010-07**

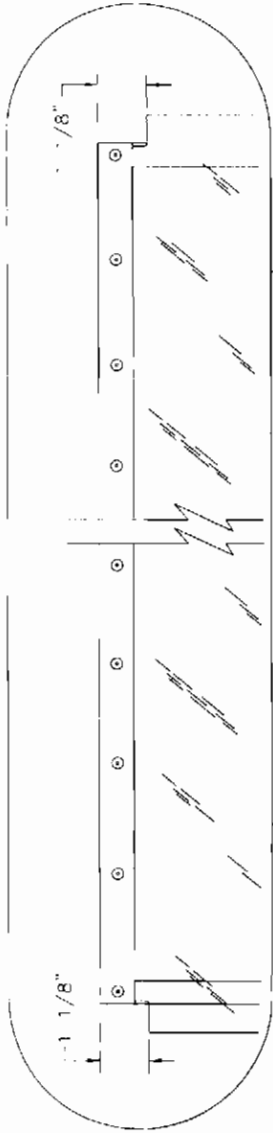


8. Re-cleco the Upper Door Lexan to the channel. Position the Lower Door panel under the Upper Panel and on top of the Door Rib. The Lower Lexan should be flush with the center top of the rib and the forward edge of the Upper Lexan. Transfer drill #30 into the Door Rib. Cleco as you drill. **HINT: Drill the center hole first to allow easier alignment.** Be sure the rib is straight. Transfer drill #30 the frame holes and Cleco. Mark and trim the Lexan as needed to be flush with the rib.
9. Re-bolt the Frame Assembly to the fuselage. Using a magic marker, trace the inside of the frame, door rib and the fuselage door opening to achieve a reference trim line. Trim off the Lexan so it extends past the bottom edge the thickness of the fuselage tubes. Trim the front edge to match with the windshield. Trim the back edge so it is even with the centerline of Station 3. **NOTE: This should be done when the door is on the plane.** See **FIGURE 010-10** for details on the edge trimming and notching. **HINT: Use a sharp sheet rock or utility knife to deeply score then snap off the trimmed edges.** Further smoothing of the Lexan edges can be done with a sanding block and sandpaper.

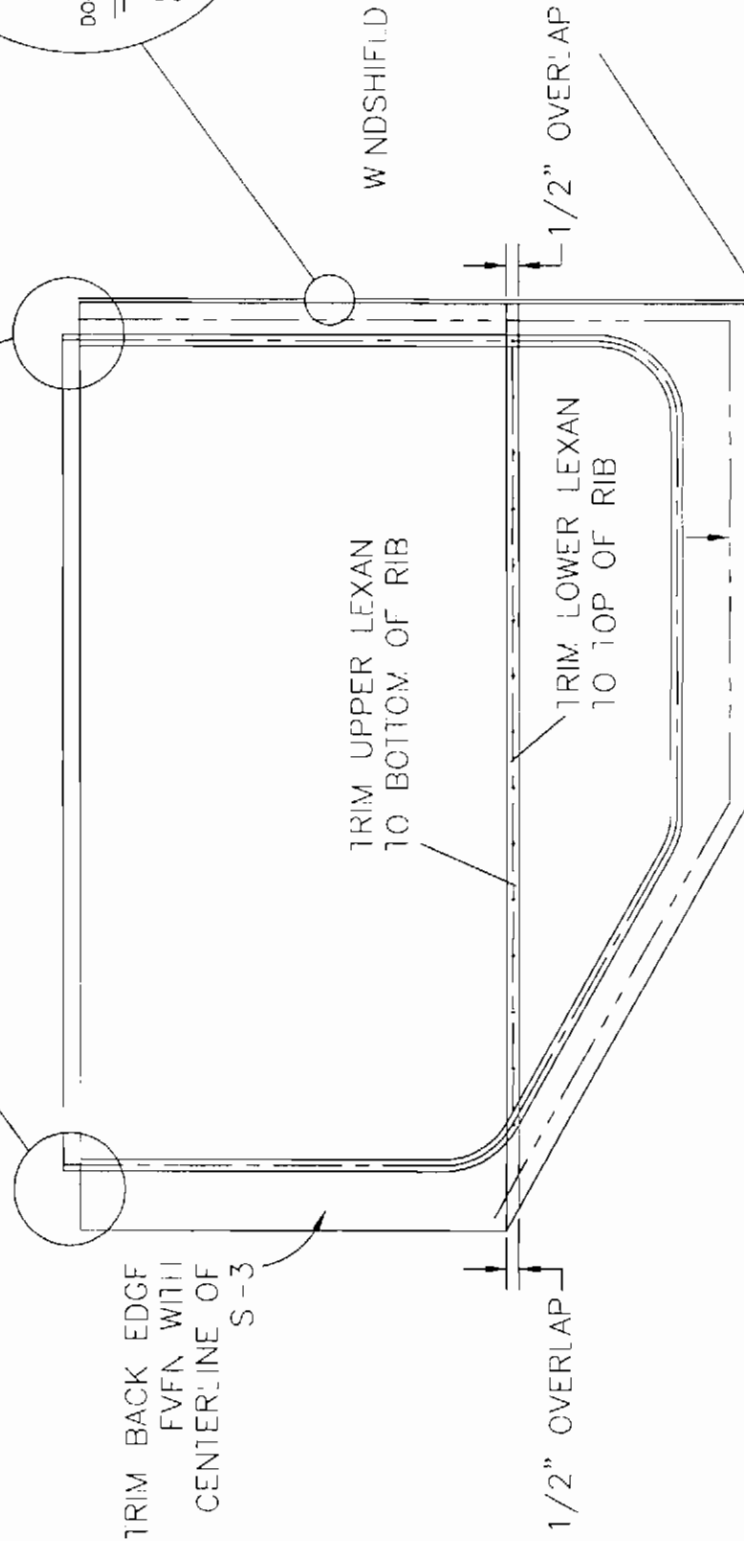
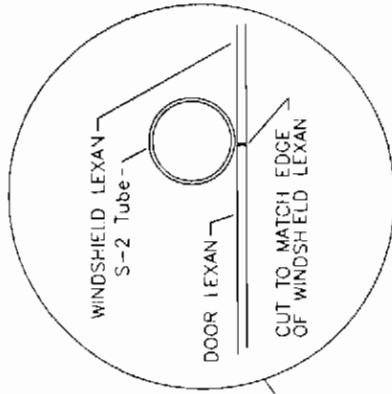
FIGURE 010-10

MD519

TOP NOTCH DETAILS



FRONT DETAIL



TRIM BACK EDGE  
FVFN WITH  
CENTERLINE OF  
S-3

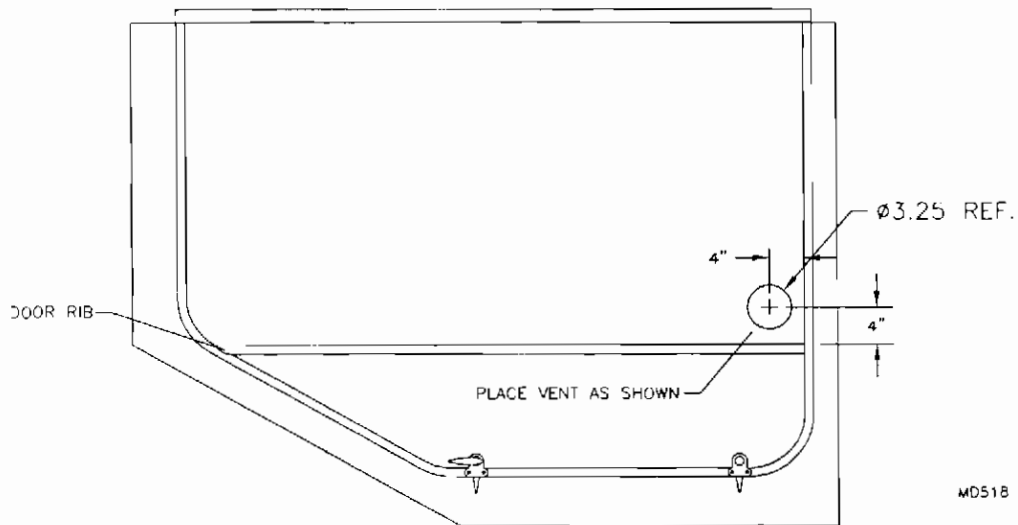
TRIM UPPER LEXAN  
TO BOTTOM OF RIB

TRIM LOWER LEXAN  
TO TOP OF RIB

TRIM OFF APPROXIMATELY 5/8"  
BELOW TOP OF COCKPIT TUBES.

11. Locate the snap vent in the forward corner above the rib. Refer to **FIGURE 010-11**. *HINT: Use an adjustable fly-cutter and cut holes in scrap first, to assure a tight fit. Remove the Upper Lexan and place on a wood block to aid drilling.*

**FIGURE 010-11**



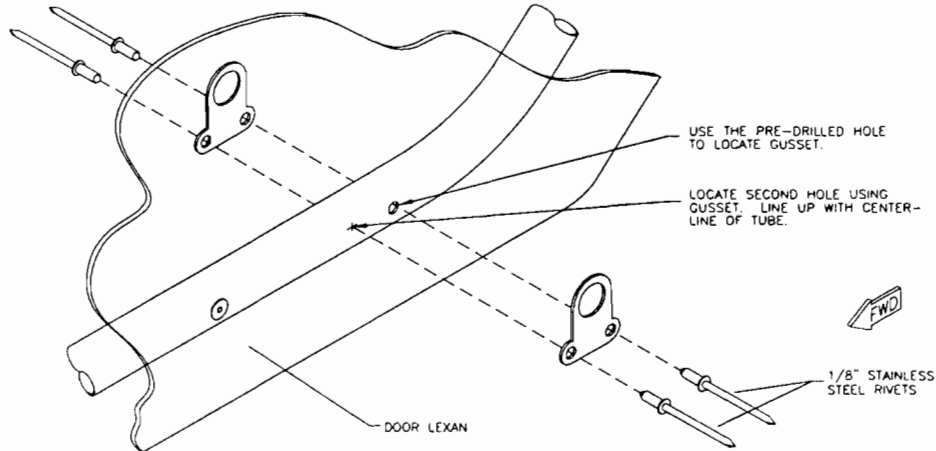
12. Glue the "D-Cell" Foam Seal to the Door Top Channel. The seal should be positioned on top of the channel, toward the inboard side. *HINT: Glue the seal with weatherstrip adhesive (3M Super Weatherstrip Adhesive #08008 works well).*

## S-6ES COYOTE II - DOOR ASSEMBLY

### DOOR HANDLE INSTALLATION

1. Fit fwd & aft door handle gussets; see **FIGURE 010A-01** and parts drawing. Remove the protective plastic film in the riveting and gusset area only. **IMPORTANT: Remove Lexan and drill the #30 holes in the Lexan only to #28.** Attach the trimmed Lexan to the door frame and rib with 1/8" AVEX rivets. When riveting to the top channel be sure to back-up with the small brass washers. Rivet door handle gussets with 1/8" Stainless Steel rivets.

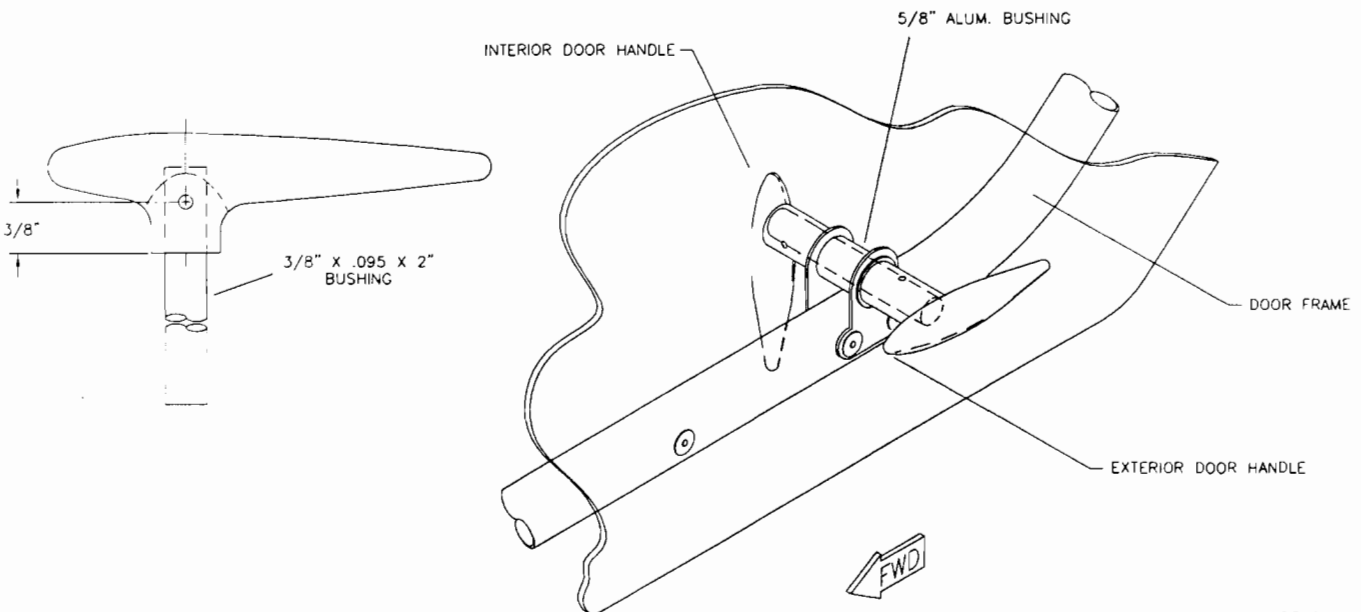
**FIGURE 010A-01**



MD520

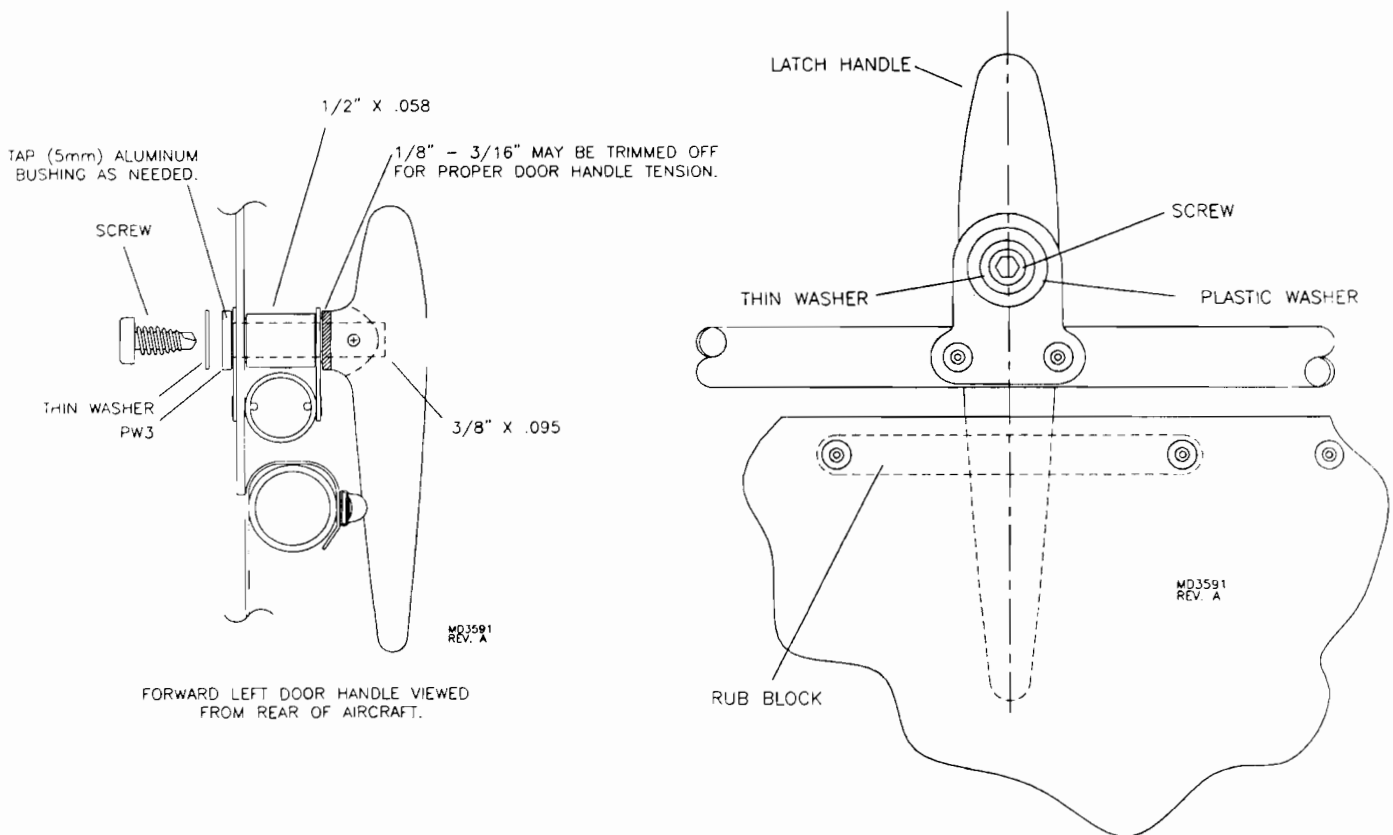
2. Insert 2" bushings 3/4" into shanks of two handles for exterior installation. Drill #30 holes through handles' shanks, per **FIGURE 010A-02**. Chase drill holes on undersides of shanks to 3/16" and insert flange nuts. Install button head screws, through shanks, into flange nuts; apply oil if installation proves too difficult.

**FIGURE 010A-02**



MD520  
02X010DR MSW 12/13/05

3. Prepare two more handles for interior; install handles and 1/2" x 5/8" long bushings per parts drawing. **IMPORTANT: Do NOT drill for or install flange nuts and screws for interior handles until fit is checked.** Orient handles at right angles such that exterior handles parallel longitudinal axis when door is latched; refer back to **FIGURE 010A-02**.
4. Bolt doors in place. Turn handles as if latching to locate rub blocks on door frame capture strips; refer to parts drawing. **NOTE: If the Optional Molded Interior is to be installed, final installation should be done after it is installed.** Hold rub blocks against capture strips to test fit. Rub blocks should provide sufficient tension to close doors snugly when latched. If tension is insufficient, bend rub blocks to bow out as necessary or trim door handle shanks. Drill through rub blocks and capture strips, into fuselage tube, taking care to drill squarely into steel. The fuselage tube is 5/8" diameter; measure 5/16" from top of strip to locate tube centerline. Rivet rub blocks in place. Install flange nuts and screws to interior handles.
5. Drill remaining handles and assemble as forward latches, per parts drawing. See **FIGURE 010A-05**. As in previous step, bow rub blocks or trim shanks for snug fit.

**FIGURE 010A-05**

## **OPERATION AND CARE OF THE DOORS**

### ***CAUTION: NEVER ALLOW FUEL TO COME IN CONTACT WITH LEXAN.***

If fuel is spilled on Lexan, spray with water or cleaner immediately to lessen the chance of crazing damage. Refer to the Windshield Section.

1. Close doors while fueling to prevent spills from running off the wing onto the door.
2. During flight always latch the forward safety catch.
3. When the door is closed, position the door handle so it is in the rub block middle dent.
4. Open the door in-flight at or below 65 MPH. Do not exceed 100 MPH with an open door.
5. The doors may be removed for flight. No speed restrictions apply. However, a very windy cockpit will result. For operations with door/doors removed, or with the doors open, make sure the pilot and passenger are properly restrained.

## S-6ES COYOTE II - DOOR ASSEMBLY

### HYDRAULIC DOOR LIFT INSTALLATION

**NOTE: Wings will need to be installed to final install the Hydraulic Door Lift.**

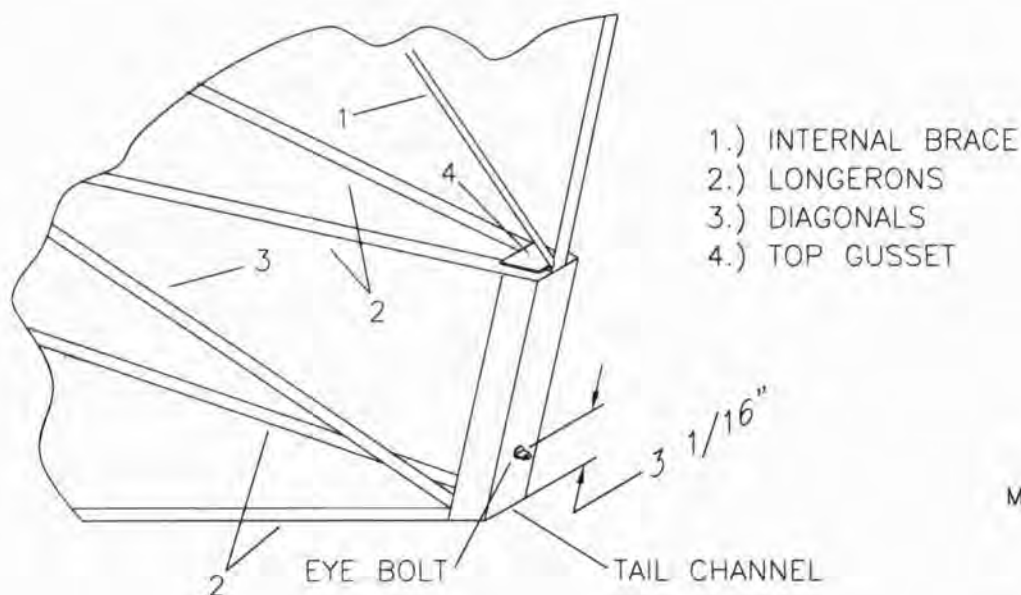
1. Slip the Aluminum Door Doubler into the aft end of the Door Frame. Position it flush with the top of the frame. Locate a #40 rivet to the forward side 1" below the pre-drilled #11 door hinge hole. Transfer drill #11 through the pre-drilled hinge hole.
2. Complete assembly of the door.
3. Install the Ball Stud to the welded gusset near the door frame at Station 3. **NOTE: If installing the Optional Molded Interior, fit up the Back Interior Panel and transfer drill 5/16" through the center gusset hole. The Ball Stud will protrude through the Back Interior panel.**
4. After the wings have been attached. Bolt the doors to the fuselage hinges.
5. Remove the locking caps from the Gas Spring ends. **IMPORTANT: The Cylinder portion of the Gas Spring must be oriented upward when final installed to prevent drying out of the shaft seal during operation.** Press over the Ball Stud in the fuselage. Press the ball stud portion of the Flat Bracket into the Gas Spring end. Re-install locking caps on Gas Spring ends.
6. Position the door so it clears the wing bottom. Clamp the Flat Bracket to the **AFT** side of the Door Frame with the ball stud forward. The holes should be centered on the Door Frame tube. Re-check for clearance with the Gas Spring extended. Transfer drill #11 and rivet.
7. During operation the Gas Spring will raise the door part way. A gentle nudge should extend the Gas Spring completely and hold the door in the full open position.

## S-6ES COYOTE II VERTICAL STABILIZER ASSEMBLY

**NOTE:** Assemble the vertical stabilizer frame and use it to set the angle of the tail channel prior to covering.

1. **IMPORTANT:** Vertical stabilizer spar and leading edge must have doublers installed at cable attach points; refer to parts drawing. Cut and debur two 6" doublers from raw stock provided. Mark middle of each doubler. Slide one into spar and another into leading edge so marks are visible through cable attach holes. Drill two #40 holes, one 2" below cable attach holes on forward side of spar, another 2" above cable attach holes on aft side of the leading edge. Rivet doublers in place and drill size drill cable attach holes to #11.
2. Drill out the lower hinge hole in the spar to 1/4" and install the nut plate on the interior side. Drill out the upper hinge hole in the spar to #11 and install the nut plate. The spreader tube nut plate will be installed in a later step.
3. Drill out one hole in each edge of each gusset to #30. Layout the frame work of the vertical stabilizer on a flat work surface. Position each gusset and drill out the corresponding hole in each tube to #30. Cleco each gusset in place. Using a #30 drill bit, transfer drill through the remaining holes, cleco as you go. Flip the assembly over and install the remaining gussets following the same procedure. Do not rivet the gussets in place at this time.
4. At this point the tailcone should be ready to have the tail channel angle set. Locate and drill a 1/4" hole 3 1/16" up from the lower end of the tail channel on center line. See **FIGURE 011-04**. Slide the vertical stabilizer in place. The stabilizer spar should sit flat against channel. Install the lower hinge bolt through the channel and spar. Refer to the **Tailcone Section** for tail channel final riveting instructions. Using the pre-drilled hole in the Station 6 top cross tube as a guide, transfer drill through it and the pre-drilled hole in the spreader tube. Remove the stabilizer assembly. Remove the gussets and debur all holes. Install the nut plate on the top side of the spreader tube. Re-cleco gussets.

**FIGURE 011-04**

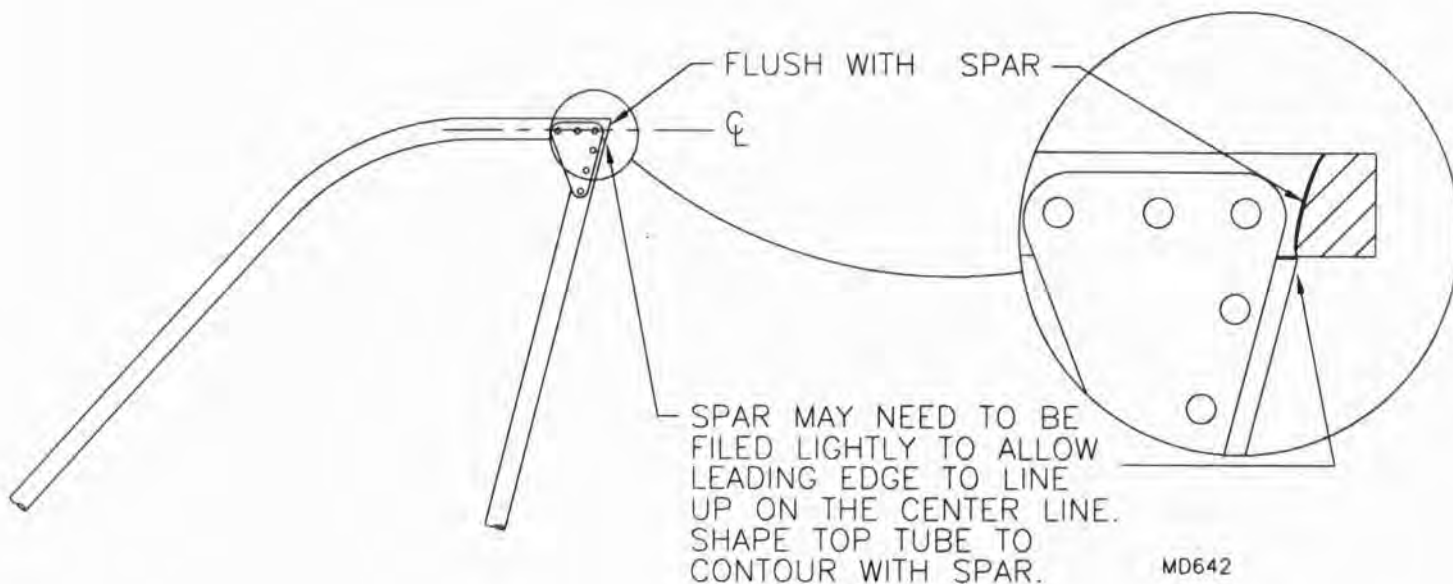


MD2984



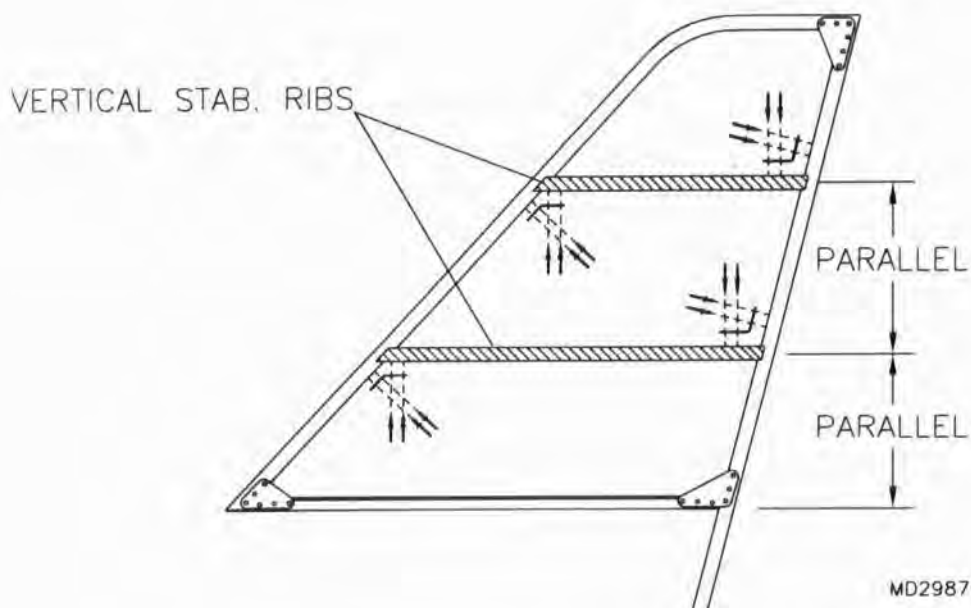
5. Contour the top of the vertical stabilizer leading edge as shown in FIGURE 011-05. A disk sander or coarse file works well. File until the leading edge radius matches the contour of the Vertical Stabilizer Spar.

**FIGURE 011-05**

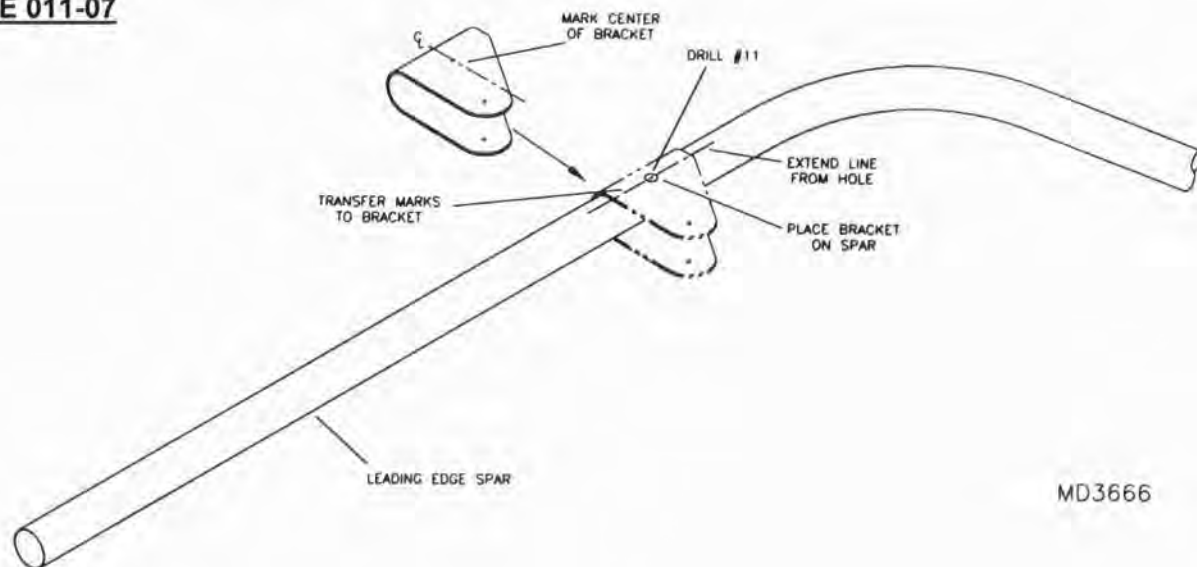


6. Straighten vertical stabilizer ribs with "fluting pliers". Drill #40 tang & rib holes to #30. Rivet Attach Tangs to ribs. Refer to parts page for orientation. Locate upper and lower ribs within vertical stabilizer; orient ribs with flanges down. Bend Attach Tangs as necessary to join ribs to leading edge and spar. **IMPORTANT:** The ribs must be parallel to the Spreader Tube. See FIGURE 011-06. Transfer drill #30 the attach tangs to the spars. Do **NOT** rivet at this time.

**FIGURE 011-07**

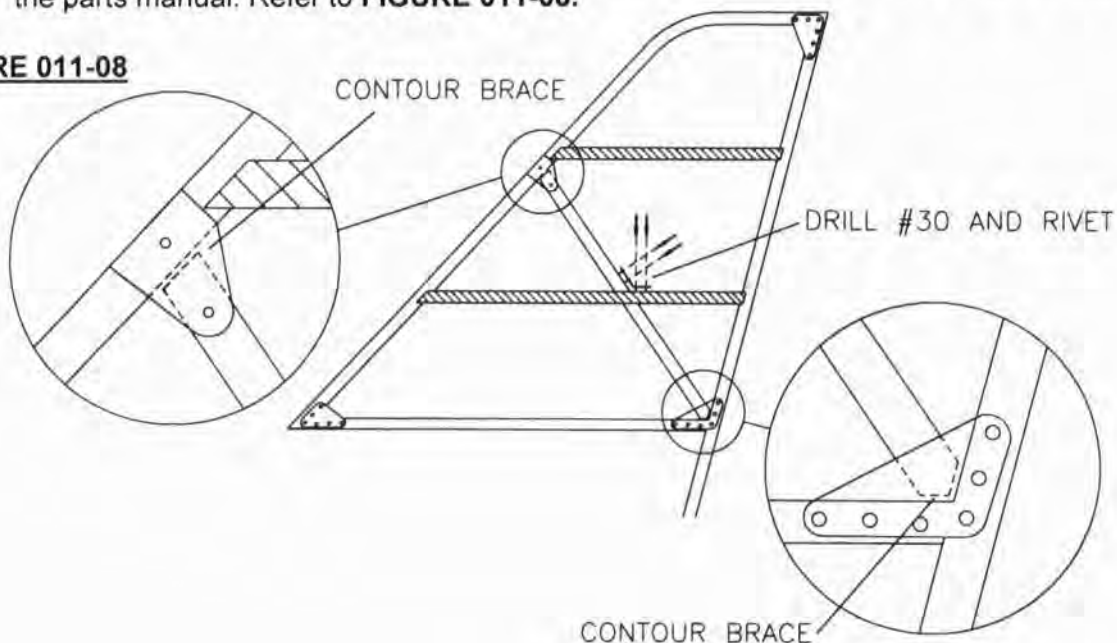


7. Mark a line extending both directions from the cable attach hole on the leading edge spar. Locate and mark the center of the U-bracket as shown in **FIGURE 011-07**. Slip the U-bracket onto the Leading Edge at the cable attach point so that the mark is centered over the hole. Note the orientation of the U-bracket. Make sure the U-bracket is tight against the spar and mark the upper and lower end of the U-bracket where the line on the spar extends. Transfer this mark to the center mark and drill #11. Temporarily bolt the U-bracket to the spar.

**FIGURE 011-07**

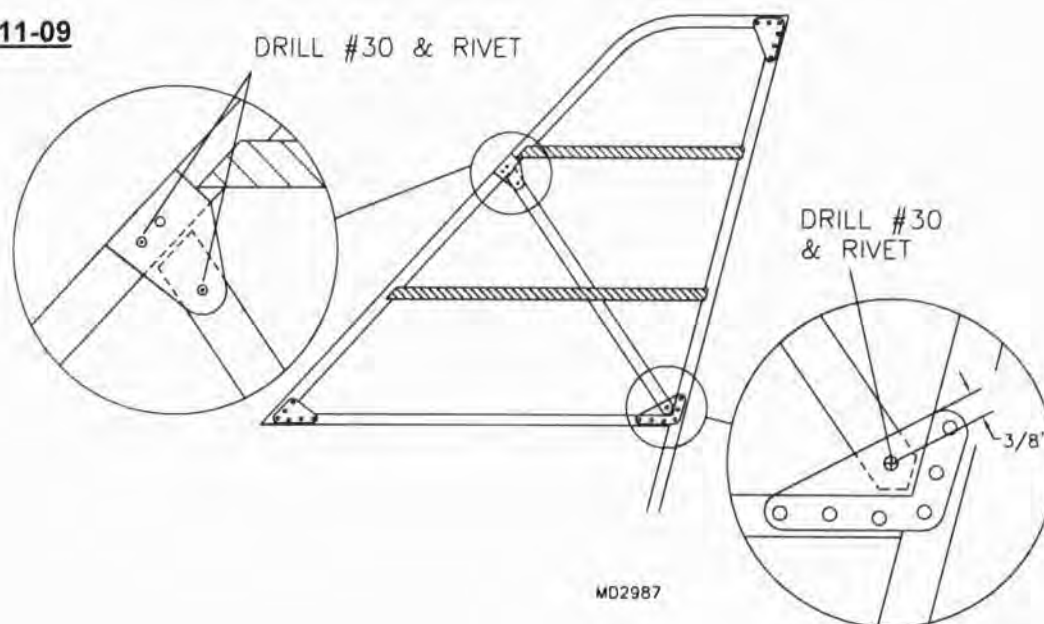
MD3666

8. Remove the lower rib and fabricate the aluminum brace tube from the raw stock provided. Refer to the parts manual. Remove one clecoed lower aft gusset. Contour the lower aft end of the brace to fit into the corner formed by the Spreader Tube and the Trailing Edge Spar. See **FIGURE 011-08**. Contour the upper end to fit against and match the angle of the leading edge spar. Transfer drill #30 through both sides of the U-bracket into the brace tube and cleco. After fitting, remove the brace tube and slip the rib over the tube and position in place. Install the aluminum brace through the rib to fit between the U-bracket and the lower aft gussets. If necessary, slightly elongate the hole in the lower rib for brace and rib alignment. Cleco the Brace tube in place. Install the Attach Angle to the rib and brace as shown in the parts manual. Refer to **FIGURE 011-08**.

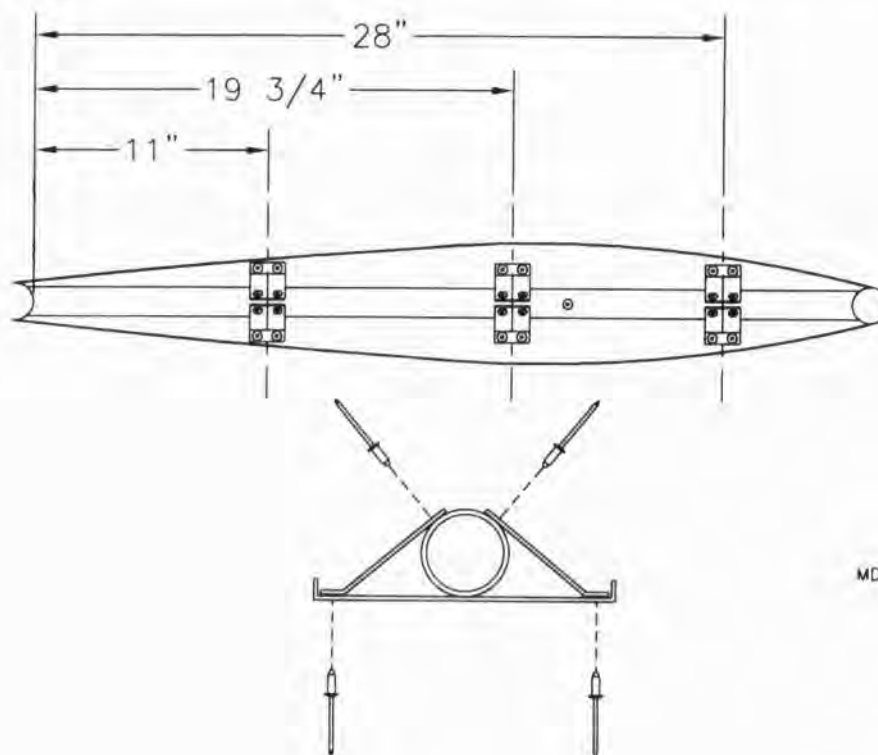
**FIGURE 011-08**

MD2987

9. Locate and drill one #30 hole, on each side, through the lower aft gussets into the brace tube and rivet as shown in **FIGURE 011-09**. Locate, drill #30, and place a rivet through both sides of the U-bracket into the leading edge spar. This will keep the U-bracket from shifting during covering. Remove the bolt in the U-bracket. Rivet the vertical stabilizer frame together.

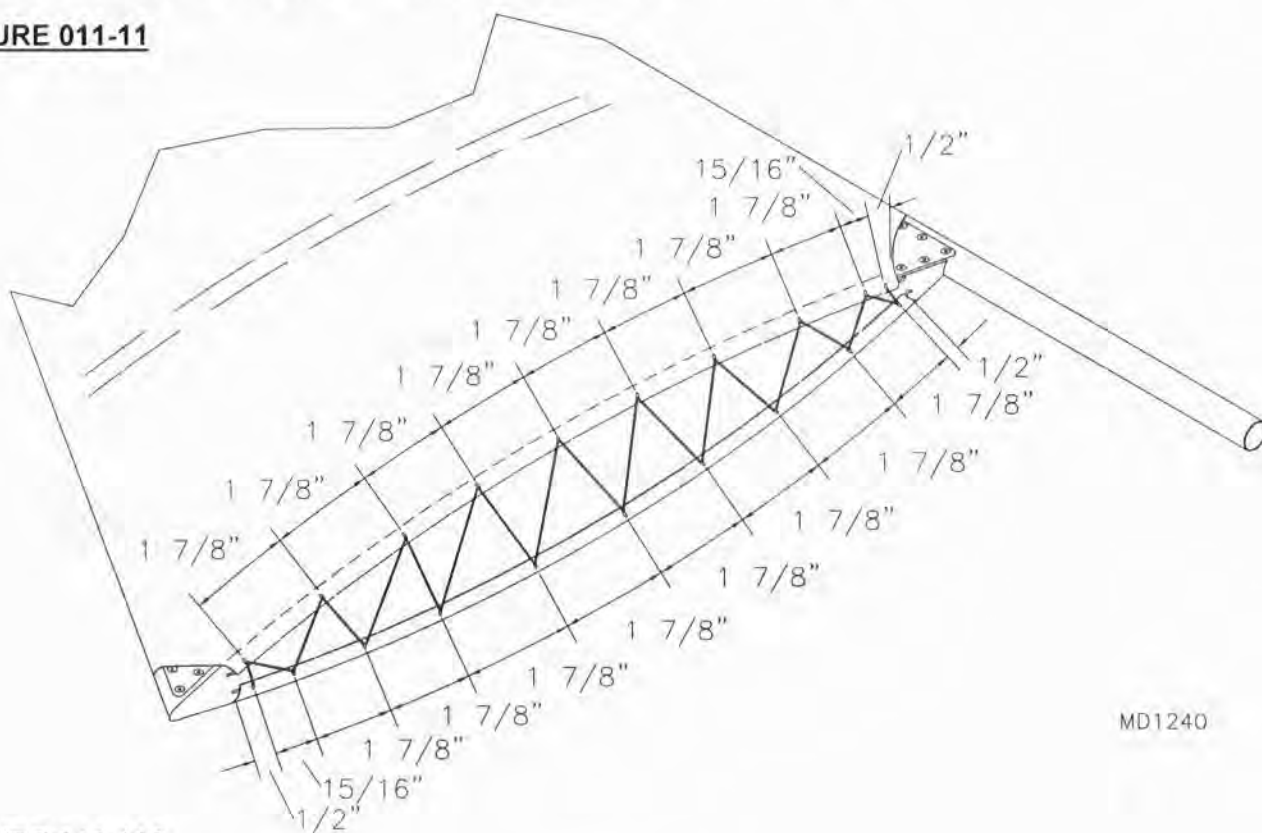
**FIGURE 011-09**

10. Drill out the second hole from the forward end of the bottom rib to #11. Align the forward attach hole in the spreader tube with this hole in the bottom rib. Using a #30 bit, transfer drill through the pre-drilled holes in the bottom rib into the spreader tube on center line and rivet in place, use (5) stainless steel rivets. It **may** be necessary to lightly file the aft end of the rib to obtain the proper fit. Locate the (6) braces on the Spreader tube and Bottom Rib. The braces sit flat against the rib and lay across the spreader tube. **NOTE:** Bend the brace flange as needed. Drill and rivet the braces in place. See **FIGURE 011-10**.

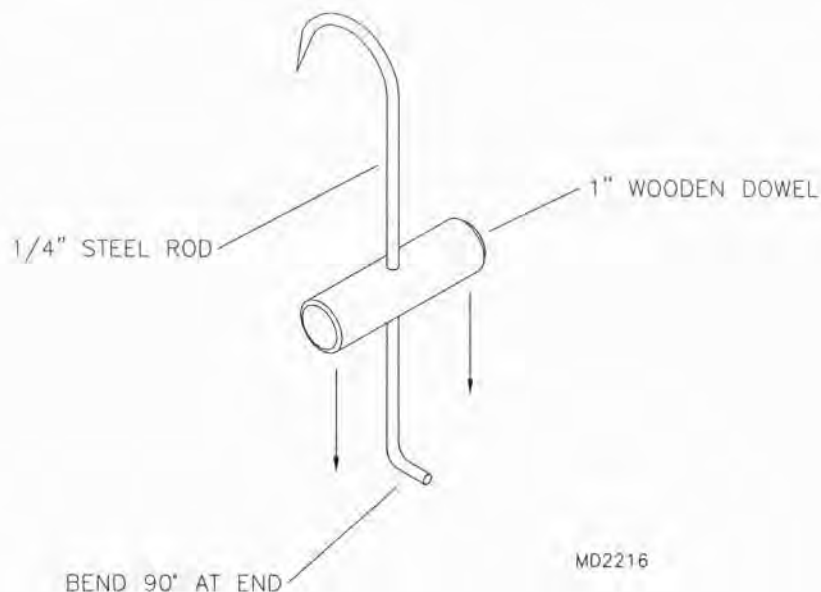
**FIGURE 011-10**

MD1257

11. Apply anti-chafe tape to the rib flanges prior to covering. Slip the skin over the vertical stabilizer. Slide the stainless steel lacing wires into the pockets on the lower end of the skin. Bend a hook on each end of the lacing wire to retain. Layout the lacing pattern as shown in **FIGURE 011-11**. Using a hot knife or soldering iron, melt through the fabric at each lace location. The slots should just touch the wire as it rests in the bottom of the pocket. Lace the rope as shown in **FIGURE 011-11**. **HINT:** Use a hot knife to melt the lacing cord tips into a flat, needle shape for easier insertion into the slots. Tension the skin by pulling the lacing cord tight. **NOTE:** Fabricate a Lacing Hook as shown in **FIGURE 011-11A** to aid in tensioning. Several tensioning passes will be required to obtain the proper tension. The skin will wrap over the bottom rib and will have a drum sound when tensioned properly. Set the vertical stabilizer aside and return to step #12 after covering the fuselage.

**FIGURE 011-11**

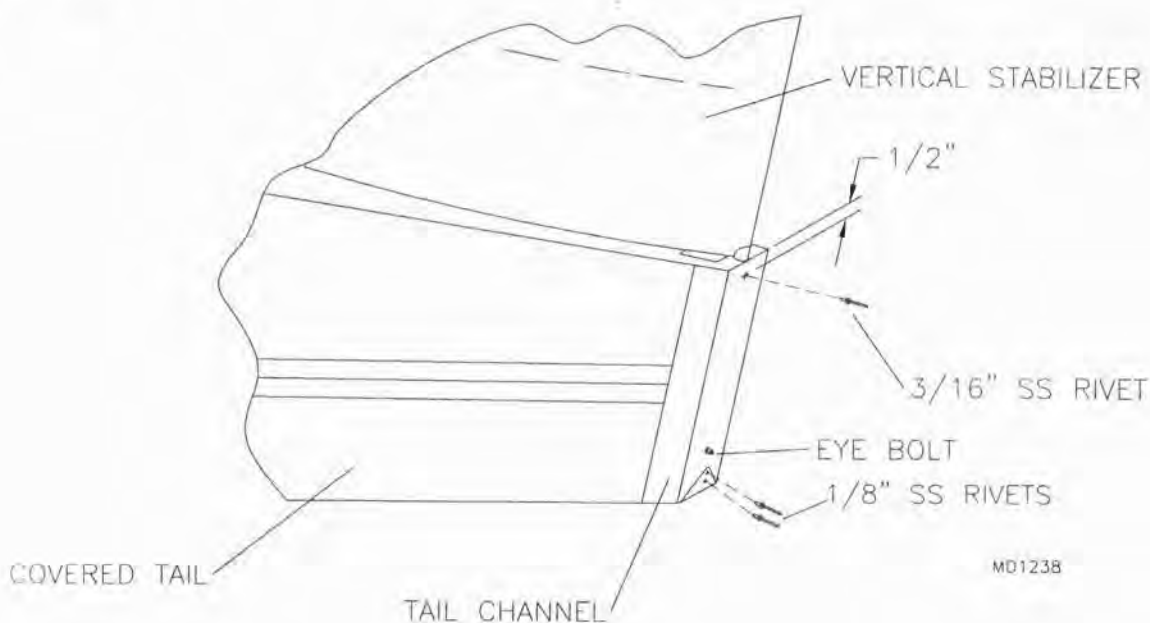
MD1240

**FIGURE 011-11A**

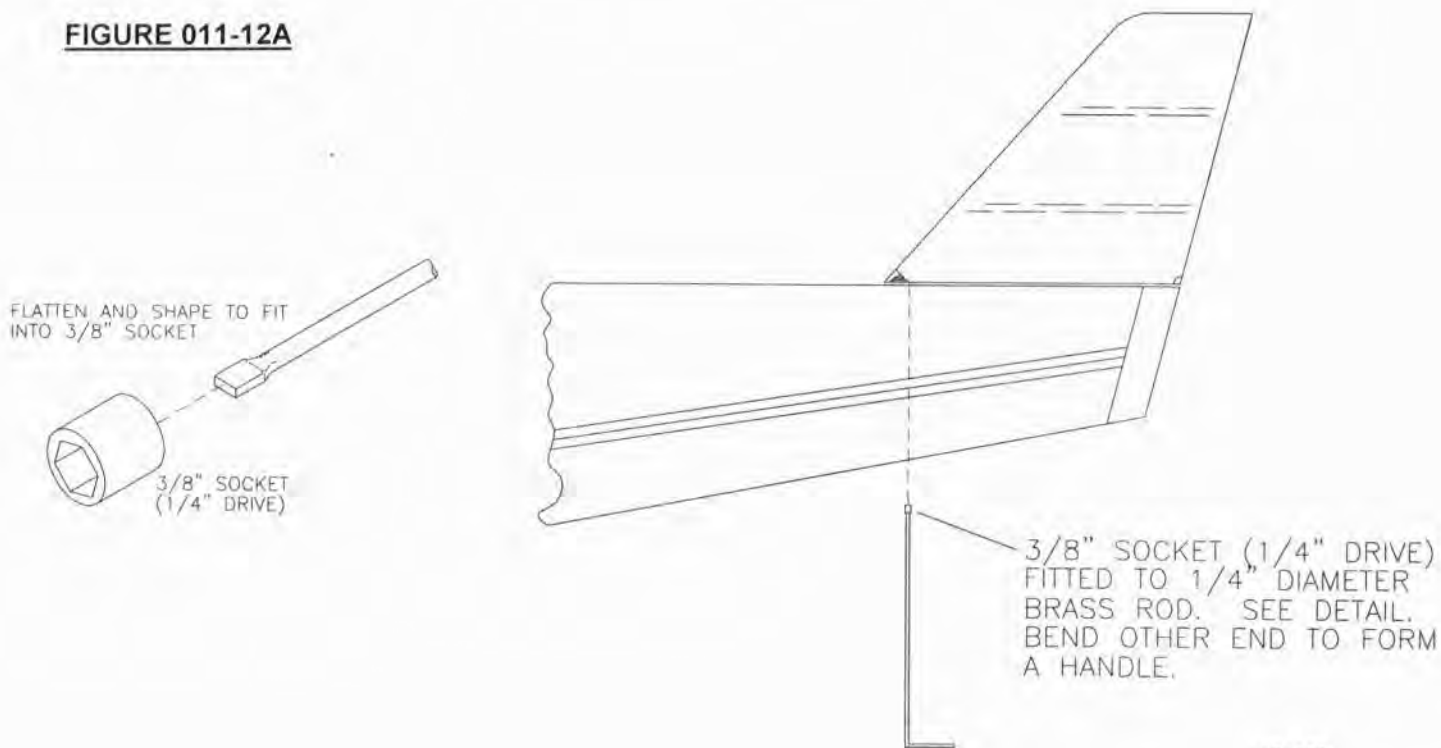
MD2216

12. Position the vertical stabilizer on the tailcone. Install the lower hinge eyebolt. Locate and drill a #11 hole 1/2" down from the top of the tail channel on centerline into the trailing edge spar and rivet. Transfer drill #30 and rivet into the trailing edge spar. See **FIGURE 011-12**. Fabricate the tool shown in **FIGURE 011-12A**. Use this tool to install the forward attach bolt through the belly lacing in the fuselage skin. This completes the vertical stabilizer assembly.

**FIGURE 011-12**



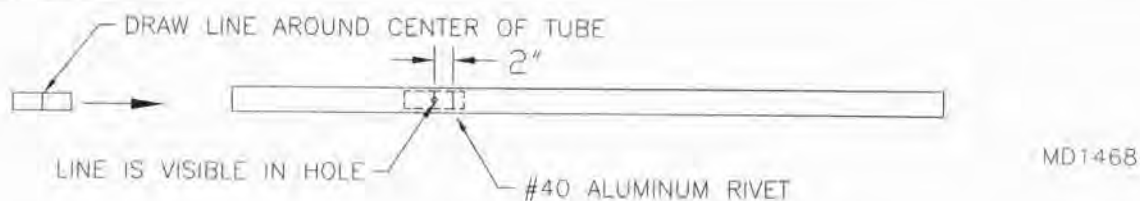
**FIGURE 011-12A**



## S-6ES COYOTE II HORIZONTAL STABILIZER ASSEMBLY

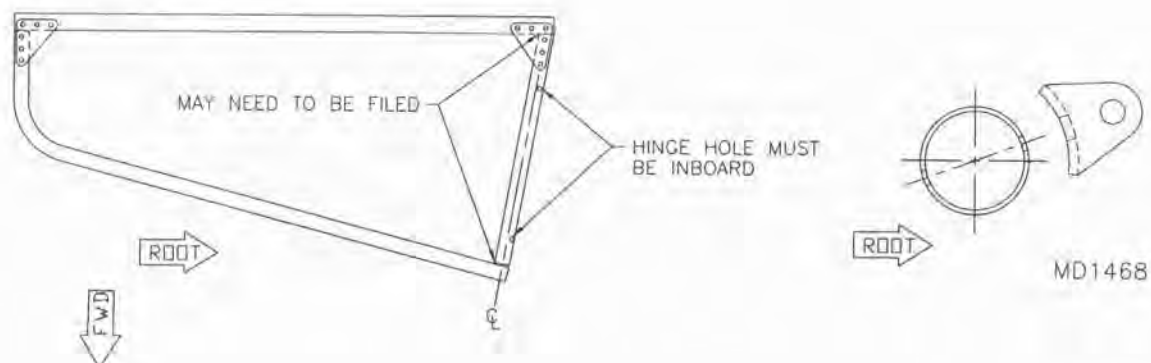
1. Select the horizontal stabilizer parts depicted on the parts page.
2. Install 6" doubler tubes at the tail cable hole approximately 2/3 outboard on the spar. Using a felt tip, mark a line all the way around the center of the tube and slide it inside the spars until the line is visible. Drill a #40 hole, 2" inboard of the cable attach hole and on the inside of the tubes. See **Figure 011A-02**. Install doubler in the two leading edge tubes in the same manner. Locate the two horizontal stabilizer spars. Rivet on the 3/16" nut plates to the hinge bracket locations on each horizontal stabilizer spar. **NOTE:** The outboard hinge hole uses the single ear nut plate

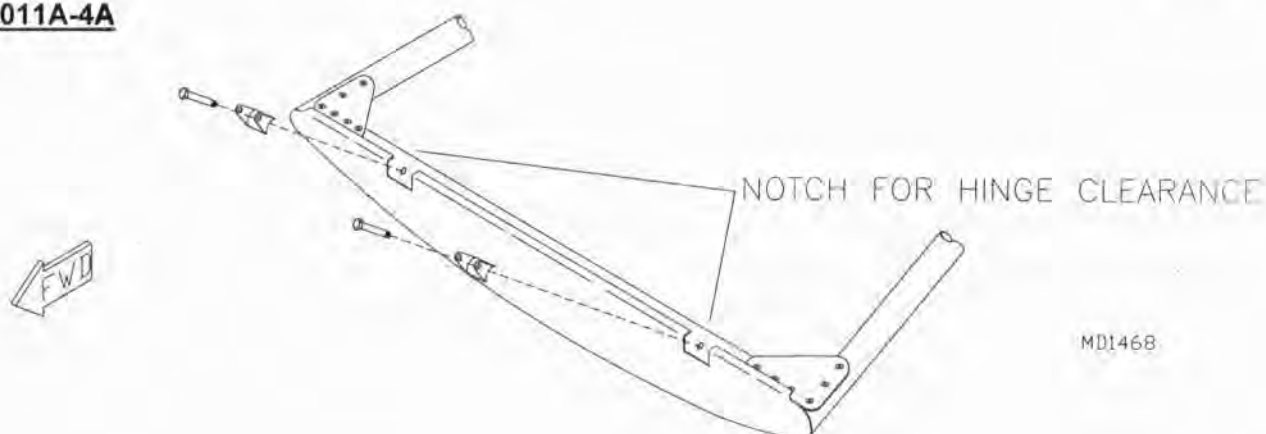
**FIGURE 011A-02**



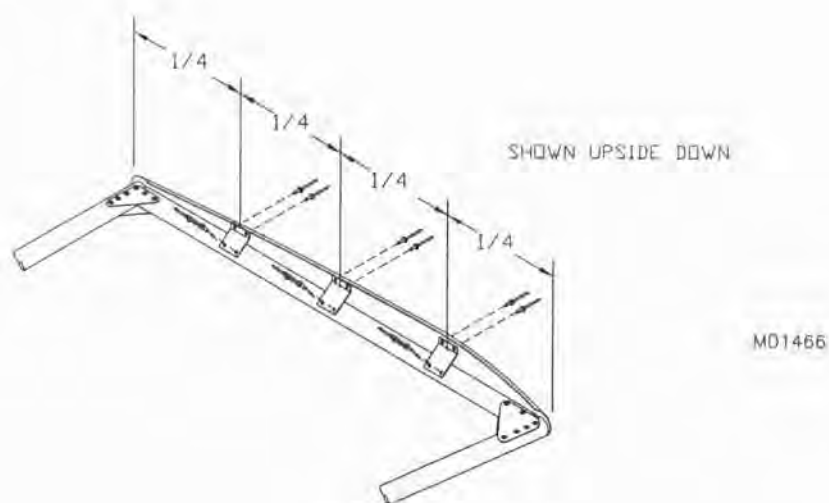
3. For the assembly of the horizontal stabilizer you will need a flat table top work surface or floor. There are three pre-drilled holes in each end of the horizontal spar. The single ear nut plate and cable attach holes indicate the outboard end. Pay careful attention to the parts drawing to select the proper gussets for each end of the spar. Cleco the 90° gusset to the top side of the outboard end of the spar. Cleco the 73° gusset to the top side of the inboard end of the spar. When attaching the gussets make sure they are oriented properly so that 3 holes are located in each tube.
4. Locate the two spreader tubes, the tubes have three gusset holes located on each end with two hinge attach holes inside of them. You will notice that the two hinge attach holes are located 20° off centerline of the gusset holes. This is done to allow the stabilizer enough room to clear the tailcone. The spreader tubes are symmetrical end for end so there isn't a specific left or right, however the tube must be oriented so the attach holes on the TOP of the stabilizer are inboard of the centerline of the gusset holes see **Figure 011A-04**. Once you have determined the proper orientation of the spreader tubes, attach the aft end to the inboard gusset on the spar. **NOTE:** You will need to file or hacksaw the end of the spreader lightly in order to line up the holes. Do this procedure for left and right stabilizer before proceeding. Please note on the end against the spar you will have to file a notch to allow the hinge bolt complete insertion in the nut plate. See **Figure 011A-04A**.

**FIGURE 011A-04**



**FIGURE 011A-4A**

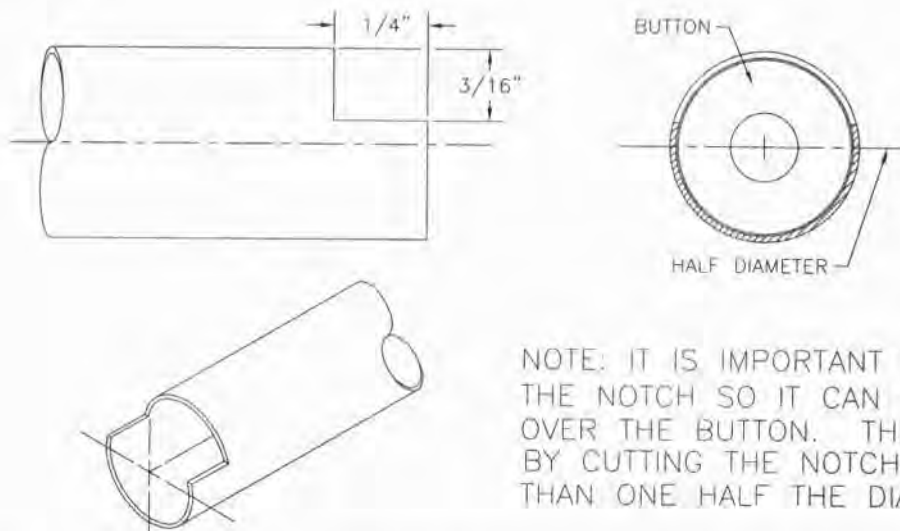
5. Locate the two leading edge tubes. Refer to the parts drawing for the correct gusset and cleco it in place on the inboard end of the leading edge. Lay this against the forward end of the spreader and determine the angle and how much the spreader tube needs to be cut to line up the pre-drilled gusset holes. Once the holes are lined up, cleco the leading edge in place. Make sure the leading edge is flush with (and touching) the outboard end of the spar. Transfer drill the three holes. **NOTE:** Since there are only three holes that are not pre-drilled it is critical that the stabilizer be laying on a flat surface when drilling. Make sure all gussets and tubes are deburred, then rivet each end with #30SSPR. Flip the stabilizer over and install the gussets on the bottom side.
6. Straighten horizontal stabilizer ribs with "fluting pliers". Drill #40 tang & rib holes to #30. Rivet attach tangs to ribs. Refer to parts page for orientation. Locate inner and outer ribs within horizontal stabilizer; orient ribs with flanges to the root. **IMPORTANT:** The more curved side of the ribs goes down. Bend attach tangs as necessary to join ribs to leading edge and aft spar and cleco. **NOTE:** The Attach tangs match to pre-drilled holes in each spar. Rivet ribs to the spars.
7. Rivet the 3/16" nut plate to the bottom of side of the hinge attach holes on the spreader tubes. The root rib can be installed by lining up the pre-drilled holes on the center line of the spreader tube. Once fit, rivet with #30 aluminum pop rivets. The root rib needs three angles riveted on the inside to stiffen it when the fabric is drawn tight. Refer to the parts drawing and select these angles. Separate the area between the forward and aft gussets into quarters and attach angles as shown in **Figure 011A-07**.

**FIGURE 011A-07**

## S-6ES COYOTE II ELEVATOR ASSEMBLY

1. Refer to the parts drawing for the parts needed to assemble the elevators. Rivet the 3/16" nut plates to the pre-drilled horn attach holes on the trailing edge. Install the buttons to and assemble the TC-1's to their prospective locations. Cut the internal brace tubes to 13" and notch one end as shown in **Figure 011B-01**. The brace should snap into place without bowing the leading or trailing edges.

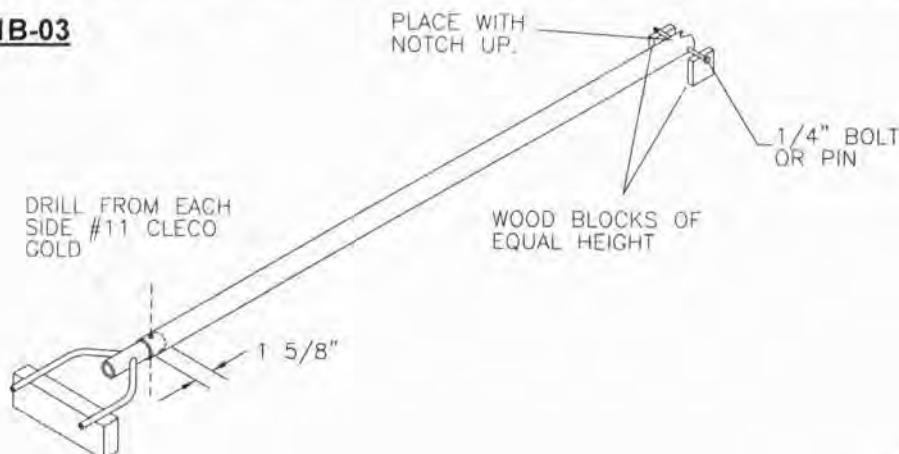
**FIGURE 011B-01**



MD1467

2. **NOTE:** This step may be done during final assembly, after the Horizontal Stabilizers are covered and clear-coated. The Vertical Stabilizer will also need to be in place. Bolt the horizontal stabilizers to the tailcone. Select the tail cables and hardware and bolt these in place as shown in the parts drawing. The cables should be adjusted so that the horizontal stabilizer is level. Use the wings as a reference. The tension should be enough so when you strum the cables they have a nice low tone. Do **NOT** over tighten or the stabilizer could be distorted.
3. Drill the #11 hole on the notched end of the elevator push pull tube out to 1/4". Slip the elevator yoke into the un-drilled end of the 1 1/4" push pull tube. Insert into push pull tube as deep as possible. Lay the assembly on a flat bench or floor. Insert a long 1/4" bolt or rod into the 1/4" hole in the opposite end. Support each side of the 1/4" bolt with lumber (2x4) of equal height. Lay similar lumber across the yoke. Re-check for flush at the yoke tube and drill through the yoke using the tube as a guide. Drill one side and cleco, flip over the assembly, and drill the other side. This procedure will assure the yoke is installed 90° to the 1/4" bolt hole at the opposite end. See **Figure 011B-03**. Bolt together.

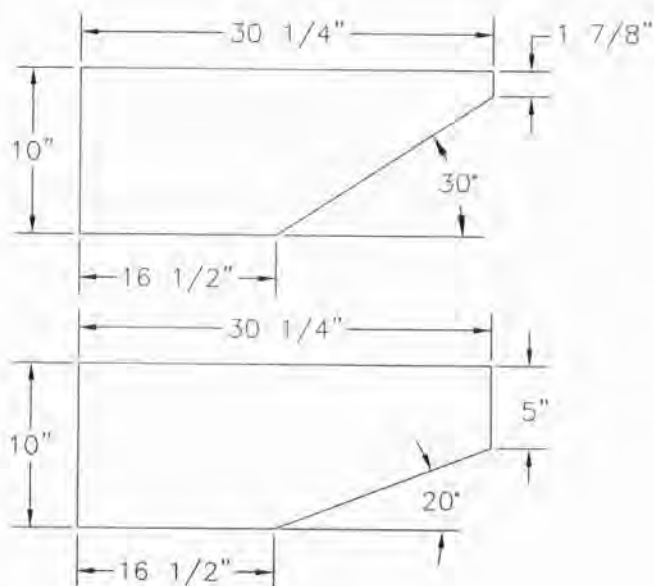
**FIGURE 011B-03**



MD1467



4. Slip the yoke/push pull tube assembly into the tailcone from either RH or LH aft side. Once the yoke is forward of the tail channel turn it level with the bolt head up and slip it out of the tailcone. Thread 1/4" plain nuts onto the 1/4" rod ends. Then thread the 1/4" rod ends into the yoke. Bolt the horns to the outside of the yoke and position in full down elevator. Check to see if the control stick assembly is against the down stop and the elevator moves up and down freely.
5. Cut out the (2) templates from cardboard. See **Figure 011B-05**. **NOTE:** An Electronic Protractor may also be used.

**FIGURE 011B-05**

MD1475

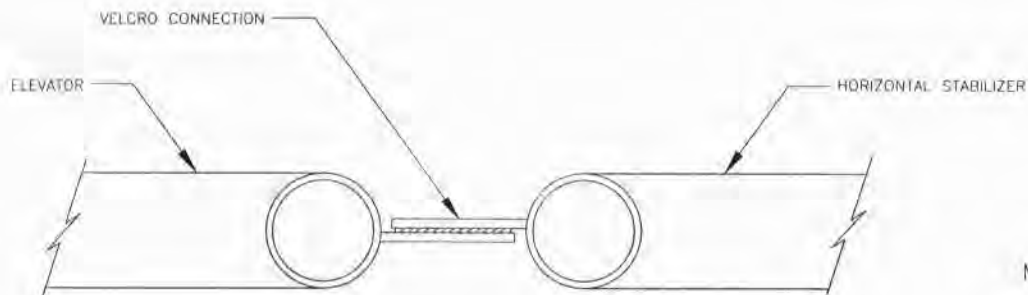
6. Hold the 20 degree template under the elevator flat against the horizontal stabilizer (be sure the control stick is flat against the stop). Adjust the rod ends until the template fits with both horizontal stabilizer and elevator flat against the template. **IMPORTANT:** The rod ends must engage at least 10 full turns. Check for evenness of the elevators. They should be flat across each other and not one lower or higher than the other. The AFT 3/4" X .058 X 3/4" aluminum tube that was slipped over the 5/8" push pull tube during **Control Stick Assembly** will now be used as a "DOWN" elevator stop. Slide the stop against the aft side of the swivel tube (built into the S-3) and drill and rivet with the rivet positioned top side. **CAUTION:** Please use a #30 stainless steel rivet. **NOTE:** Before riveting be sure you're your fingers on the control stick can clear any instruments protruding from the panel.
7. The FWD 3/4" X .058 X 3/4" aluminum tube that was slipped over the 5/8" push pull tube during **Control Stick Assembly** will now be used as an "UP" elevator stop. Using the 30 degree template hold the elevator in position with the seat belts. Slide the stop against the fwd side of the swivel tube (built into the S-3) and drill and rivet with the rivet positioned top side. **CAUTION:** Please use a #30 stainless steel rivet. Check the system for proper movement. **IMPORTANT:** Be sure the Loc Rings are through the 1/4" bolt attaching the horns to the yoke. (Check this prior to each flight).

## S-6ES COYOTE II

### COVERING THE HORIZONTAL STABILIZER AND ELEVATOR

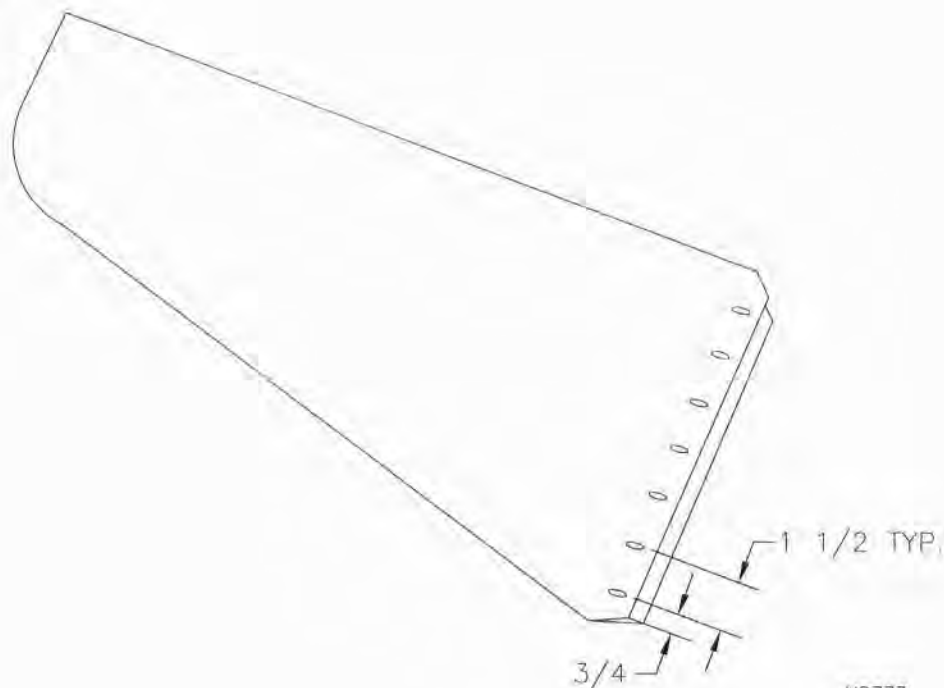
1. Covering the horizontal stabilizer is very similar to the vertical stabilizer discussed earlier in this section. Pull the skins down over the frame as tight as possible. **NOTE:** *Make sure you have the proper skin for each stabilizer.* You can tell this by the Velcro gap seal. The horizontal stabilizer Velcro should overlap the elevator velcro on top as show in **Figure 011C-01**. Remember that the inverted airfoil ribs are the bottom side of the stabilizer. Slip the small stainless steel lacing wire into the sleeves in the cover. Layout and use a hot knife to make 1/16" x 5/16" slots as shown in **Figure 011C-01A**. Tie the lacing rope at one end and lace the rope as described for the vertical stabilizer. Once laced, work your way back and forth pulling the rope tight. The skin is tight when it is wrinkle free and the lacing slots are no longer visible on the top or bottom of the stabilizer. See **Figure 011C-01B**. Use a hot knife for the attach holes. The stabilizer is now ready for clear coat and final assembly.

**FIGURE 011C-01**



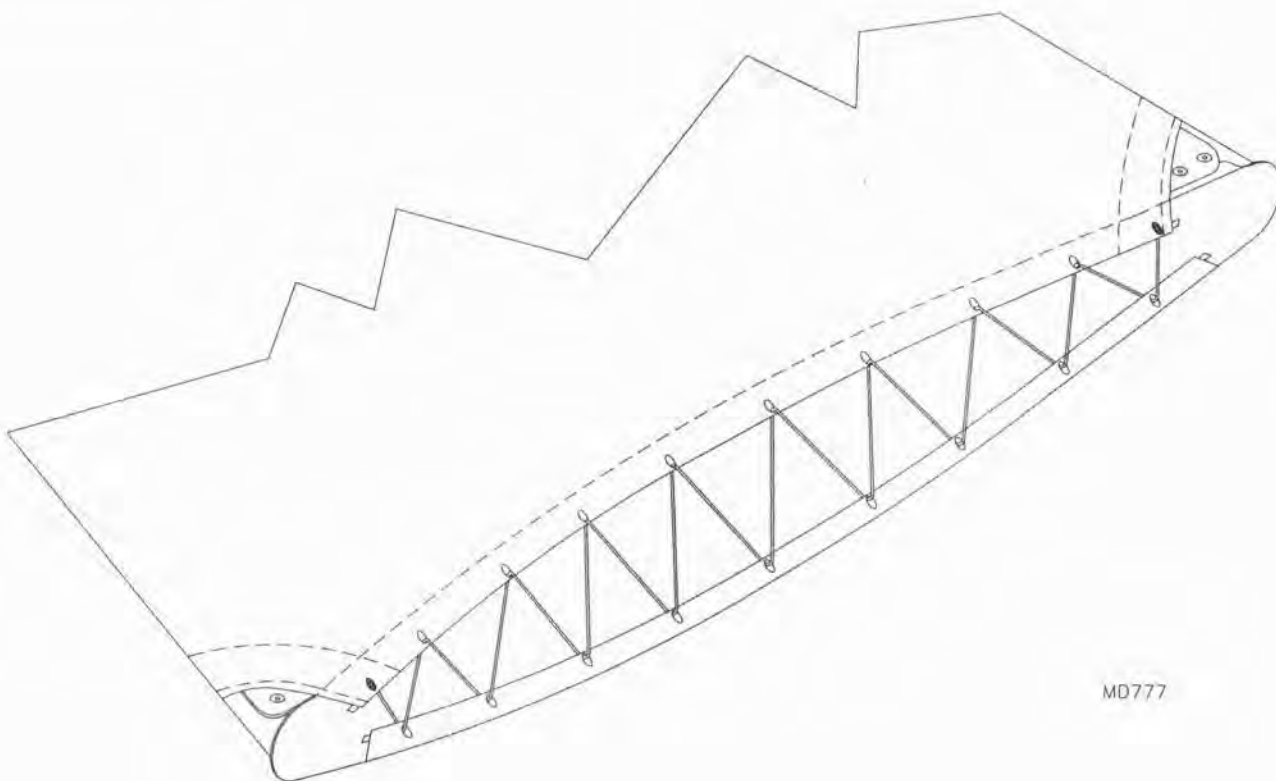
MD1475

**FIGURE 011C-01A**



MD777

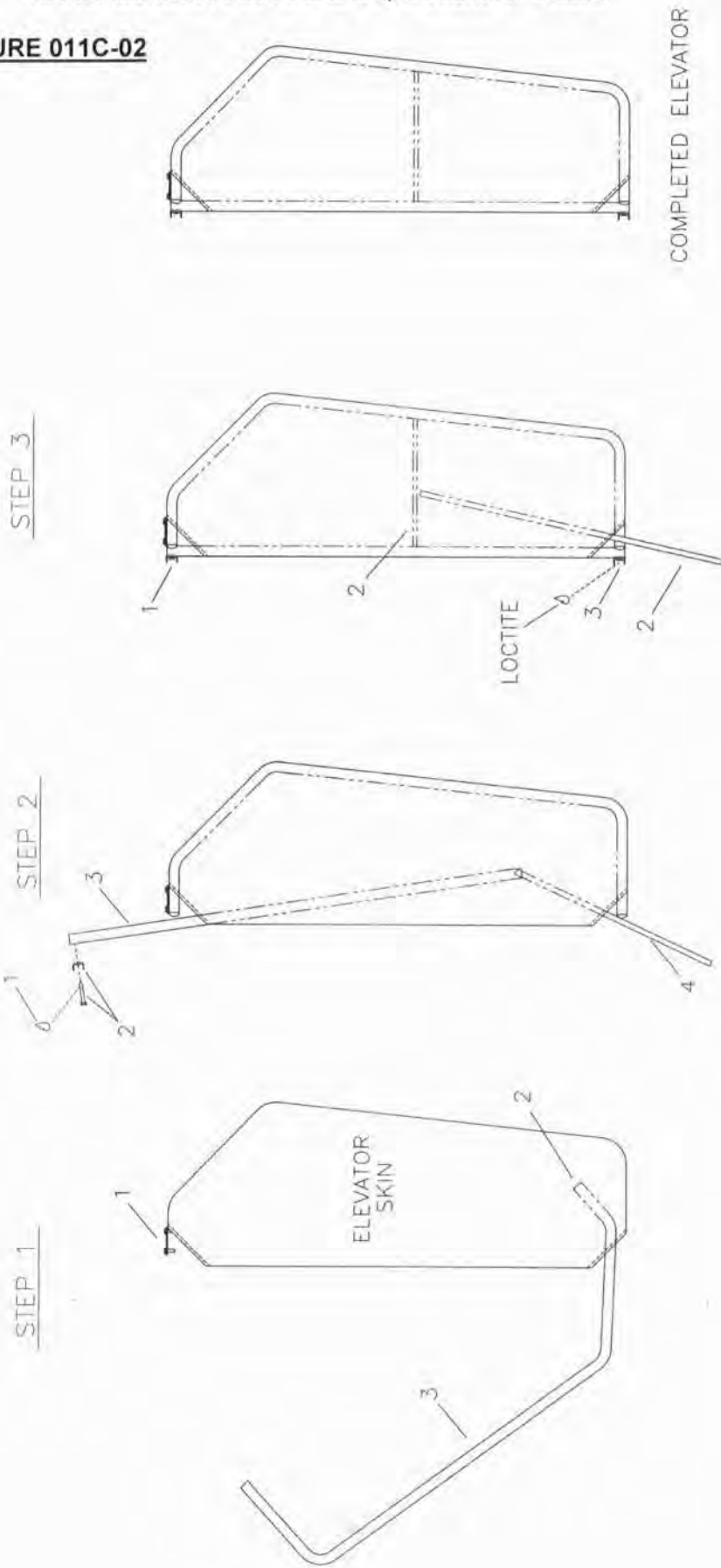
**FIGURE 011C-01B**



MD777

- Refer to the **FIGURE 011C-02** and **Figure 011C-02A** for covering of the elevators. Fabricate the Brace Installation Tool shown on **FIGURE 011C-02A**. The Brace Installation Tool may also be rented from RANS. Contact RANS Parts Department for details.

**FIGURE 011C-02**

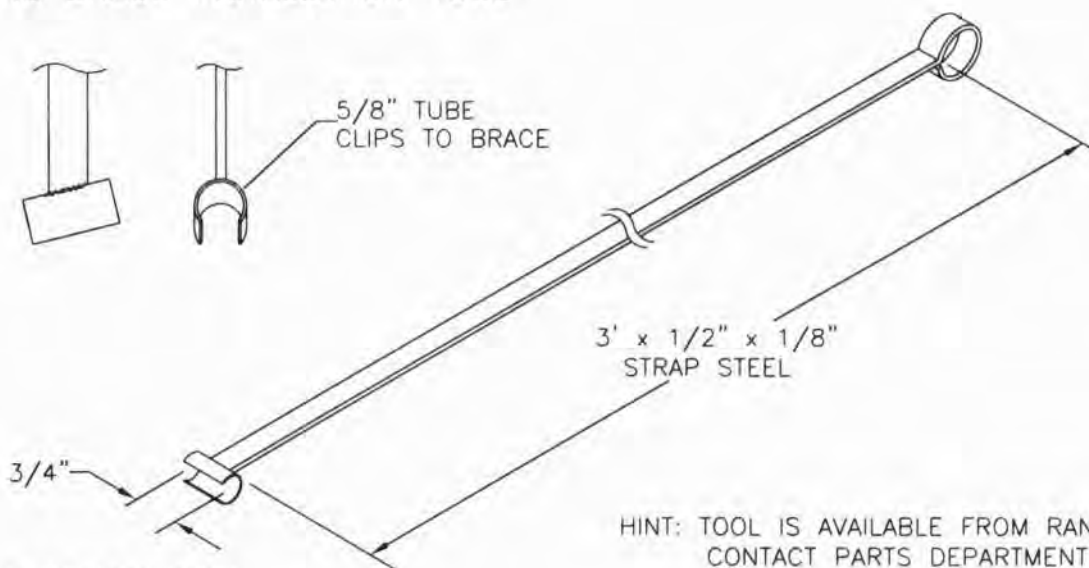


- |  |   |  |
|--|---|--|
| <ol style="list-style-type: none"> <li>ASSEMBLE ELEVATOR HORN</li> <li>ASSEMBLE END FITTING TC-1.</li> <li>ELEVATOR TRAILING EDGE</li> </ol> | <ol style="list-style-type: none"> <li>LOCTITE THE 1/4" HINGE BOLT.</li> <li>HINGE BOLT AND HINGE</li> <li>ELEVATOR SPAR</li> <li>INSERT SPAR, POP OVER LOWER END OF TRAILING EDGE USING A LARGE FLAT HEAD SCREWDRIVER OR 3/4" TUBE FOR A LEVER.</li> </ol> | <ol style="list-style-type: none"> <li>TIGHTEN TOP HINGE AND BOLT.</li> <li>INSTALL INTERNAL BRACE TUBE, USE INSTALLATION TOOL</li> <li>INSTALL HINGE AND BOLT WITH LOCTITE</li> </ol> |
|--|---|--|

MD776

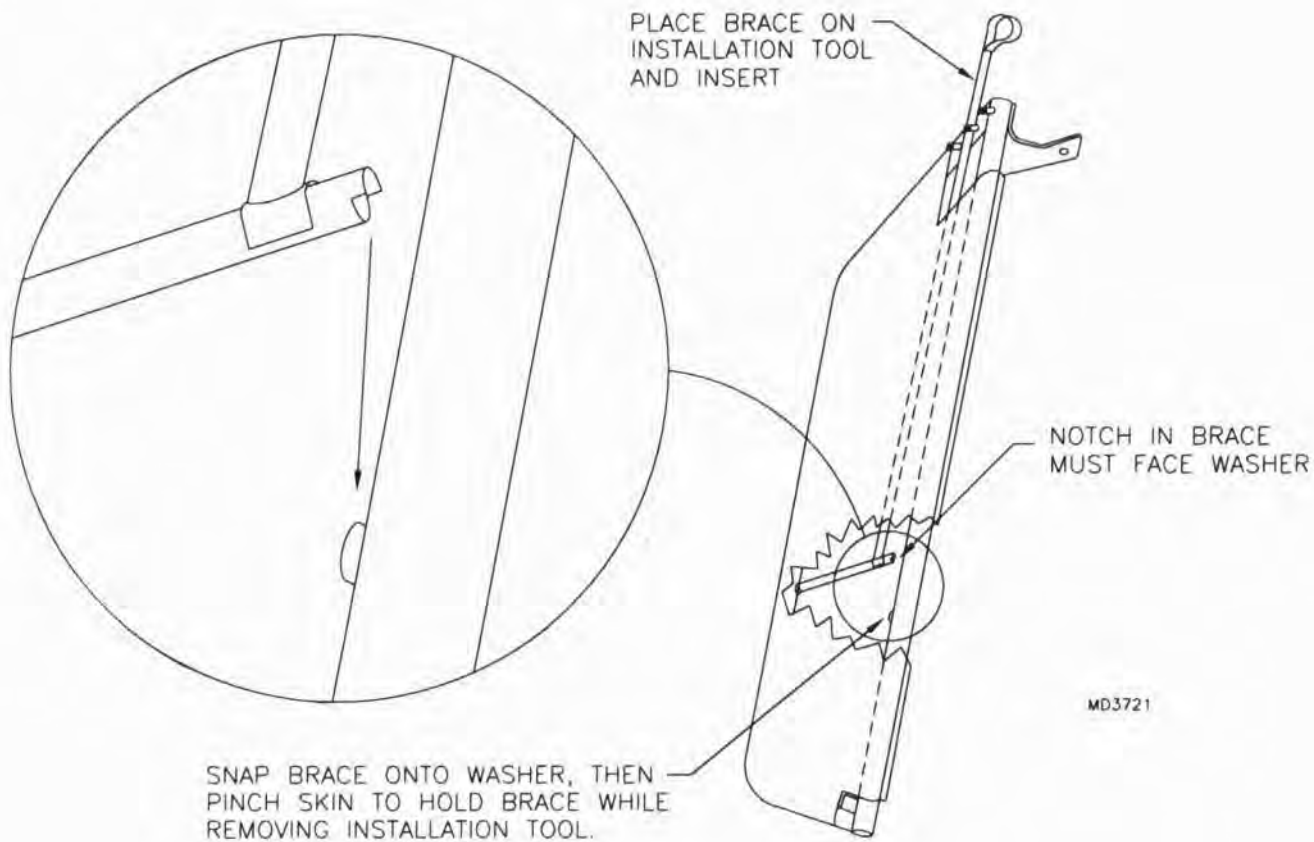
**FIGURE 011C-02A**

RANS BRACE INSTALLATION TOOL



CLIP IS FABRICATED FROM A 5/8" X .058 TUBE WELDED TO STRAP AT APPROX. 20° ANGLE

HINT: TOOL IS AVAILABLE FROM RANS; CONTACT PARTS DEPARTMENT



MD3721

**S-6ES COYOTE II BRAKE ASSEMBLY**

Hydraulic Brake assembly is included in the following sections.

Section 002 – MAIN GEAR ASSEMBLY

Section 004 – FLOOR BOARD / HYDRAULIC BRAKE SYSTEM

## S-6ES ENGINE MOUNT GENERAL INSTRUCTIONS

1. Select the proper hardware and components depicted on the parts page.
2. Assemble the barry mounts and plates as illustrated. Torque these bolts 5 to 7 ft.lbs.
3. Bolt on the propeller (see engine for correct hardware). **NOTE:** Some installations have large spinners, refer to Spinner Installation for details to complete prop attachment. Use 10 ft. lbs. for proper propeller torque.
4. Check the face of the prop with a protractor and firewall. 0 degrees of down thrust is used on the S-6ES. Adjust by adding or removing the shims between the engine and mount plates.
5. Next check the prop tracking by measuring from a reference point on the fuselage to the prop tip. Have the prop positioned level when measuring. Turn through the prop (ignition off?) and check the other tip. Both should read the same distance from the reference point. If they don't, try re-torquing the prop bolts until the prop is in track.
6. Check for offset by using a reference point on each side of the fuselage such as the strut attachments on the S-6ES & S-6XL. The right side should measure 1/8" to 1/4" more than the left to add a little left thrust on **503's** and **582's**. The exact amount can only be determined by flight testing. Add washers between the mount and firewall on the RH side to adjust. The right amount is when the plane flies straight in level flight at its normal cruise speed.

Other factors such as wing set (wash out), aileron, flap, and tail rigging will effect the aircraft's ability to fly straight. Consider these factors when rigging offset. You'll know it's not the engine angle if the offset exceeds 5/8 of an inch. **IMPORTANT:** The firewall engine bolts must have (3) threads or more showing after torquing to be acceptable.

## 912 DYNAFOCAL ENGINE MOUNT INSTRUCTIONS

1. The 912 dynafocal engine mount will attach to the firewall in the same manner as previously detailed for all engine mounts. Refer to the parts drawing and select the hardware to attach the top two mounts to the firewall. After bolting these in place, use the bushings on the lower two mount points as drill guides and drill the firewall attach points 1/4", install hardware and torque all (4) bolts to 7 lbs.
2. Before installing the engine onto the mount, the 912 engine attachments need to be bolted to the engine. Slide the 3/8" bolt and washer through the bushing before attaching the brackets to the engine with the 10MM bolts. When installing the engine, slide the 3/8" bolts up as far as possible, have the upper rubber bushing and steel bushing in place, then lower the engine into its approximate location and gently feed the bolts into place. Install the lower rubber and steel bushing and tighten them in place.
3. **IMPORTANT:** *Install the "S" shaped radiator hoses to the aft cylinder head coolant fittings. The "S" hose prevents coolant hose conflict with the engine mount. Install on both right and left aft fittings. Trim hose as required to prevent binding. IMPORTANT: Rotate the water pump inlet to the 8 o'clock position.*
4. Shim the left side of the **912** engine mount as shown in the parts drawing. 1/8" to 1/4" is desired at the left tip of the prop from a reference point on the fuselage. The prop should be horizontal for measurements to be taken.

## S-6ES COYOTE II ENGINE INSTALLATION

Provided with this manual are photos showing details of the 80 and 100 hp 912 installation. Please use these as a reference, variations may be apparent.

### CARBURETION & EXHAUST FOR 503'S & 582'S DUAL AND SINGLE CARBS

1. The carbs should come with a primer nipple installed. However, if not, drill and tap the carbs for the small brass nipple. Locate the nipple on the filter side of the carb at about a 3:00 o'clock position on the side to the rear. Be careful not to get aluminum particles in the carbs.
2. Remove the choke levers from the carbs. (Leave the plunger assembly intact.)
3. Install carbs to the engine. Secure 90 degrees to the crankcase split line.
4. Route primer lines to nipples, pump and "T"'s as required. Keep all fuel lines away from heat sources such as the muffler. Safety all connections to prevent leakage. Plastic tie lines to prevent movement.
5. Bolt the fuel pump in close to the engine so the impulse line is no longer than 15". Run fuel lines in a manner so they are far from heat sources and secured but not crimped to prevent shifting or kinking. Clamp or safety all fuel line connections.
6. Follow the Rotax manual for throttle and other carburetion installation tips.

### 503/582 MUFFLERS

7. Install the muffler and manifolds appropriate to model type and cowling cut outs. Torque down the exhaust "Y" pipe evenly. Adjust spring tension by bending the loops wider or narrower. Try not to over tension the springs or they will break. \*The muffler's rubber mountings vary from model to model but the concept is the same. To allow enough freedom of movement so the engine vibration is absorbed without damaging the muffler. Regular inspections of the muffler should be conducted. Cracks may develop and should be welded. A severe loss in performance may occur when a muffler comes apart! Keep the engine compartment clean! New sources of dirt, oil and grim can be early warnings of trouble. **EXAMPLE:** Fuel oil mix on the engine could mean a split crankcase seal which eventually could cause a seizure. Look for trouble and correct it ASAP!!!

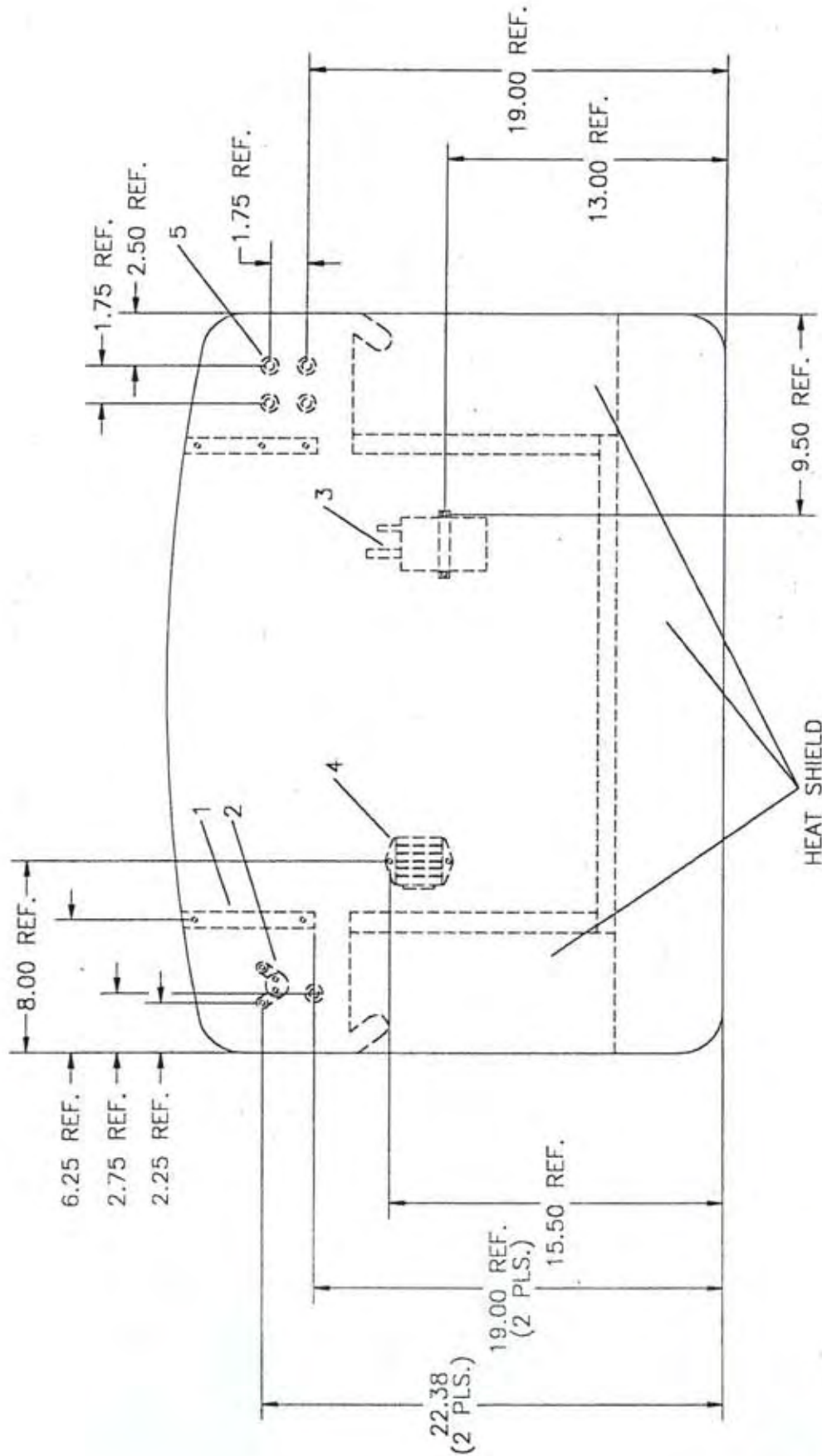


## INSTALLATION OF 912 ACCESSORIES

1. Gather the parts for installing the coolant bottle, regulator, throttle, and solenoid.
2. For installation of the accessories use the measurements from the drawing of the firewall, see **FIGURE 014-02**. The coolant bottle is attached using 3/16" aluminum pop rivets. The coolant bottle and clamp are called out in the cooling system.
3. Mount the regulator and solenoid to the firewall in the proper positions using the proper hardware.  
**NOTE:** Drill carefully when penetrating the firewall so as not to inadvertently catch the fabric on the other side with the drill bit.

FIGURE 014-02

- 1. RADIATOR MOUNT (QTY. 2)
- 2. SOLENOID
- 3. COOLANT RECOVERY BOTTLE
- 4. REGULATOR/RECTIFIER
- 5. RUBBER GROMMET (QTY. 5)



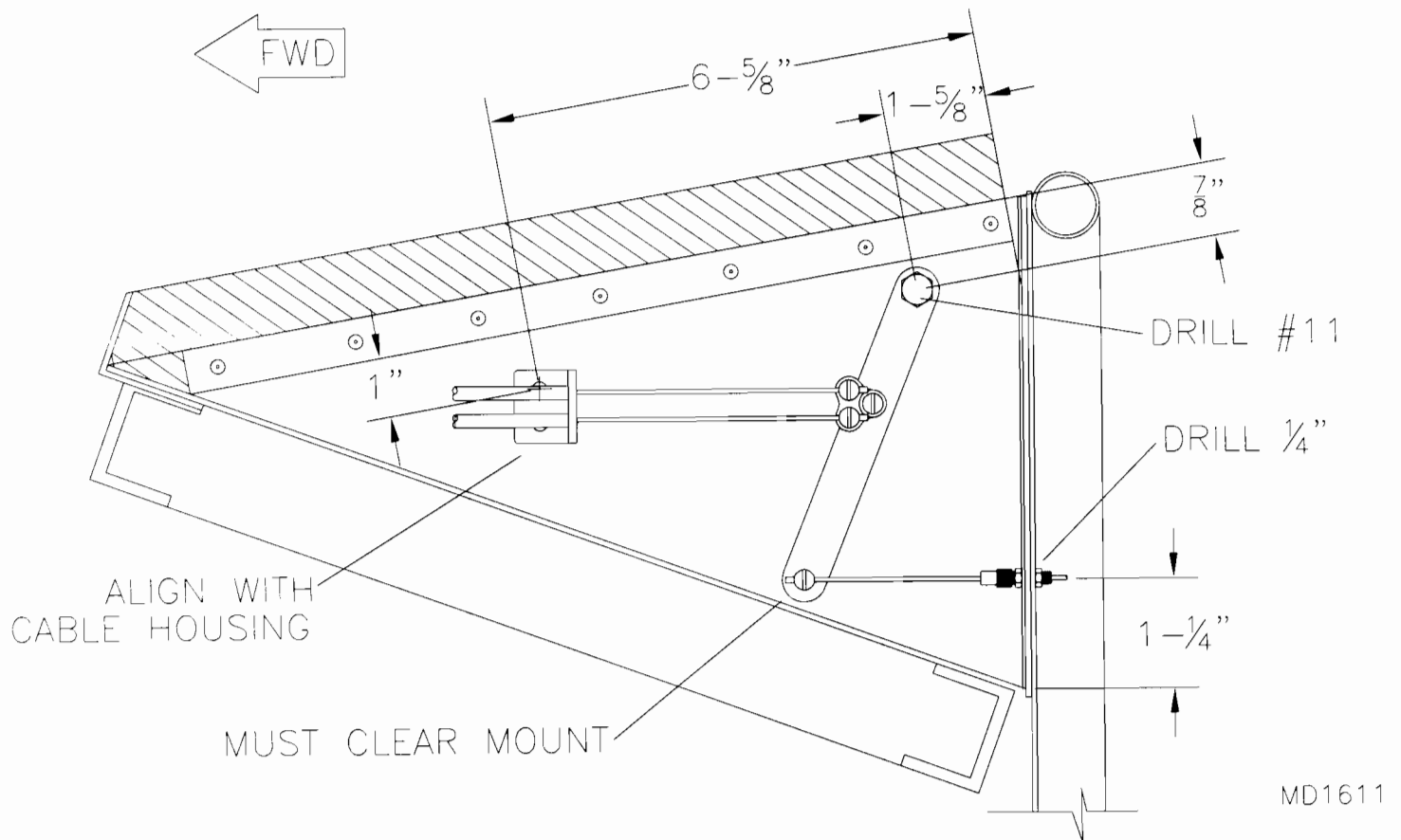
MD1312

HEAT SHIELD

## RADIATOR PREPARATION FOR THE CHOKE SYSTEM

4. Install the choke system to the left side of the radiator mount as shown in **FIGURE 014-11**. Use Wire Stop/Screws to retain choke cables and wire. If system does not operate properly check for a hard bend or a tight radius in the cable or cable housing.

**FIGURE 014-011**

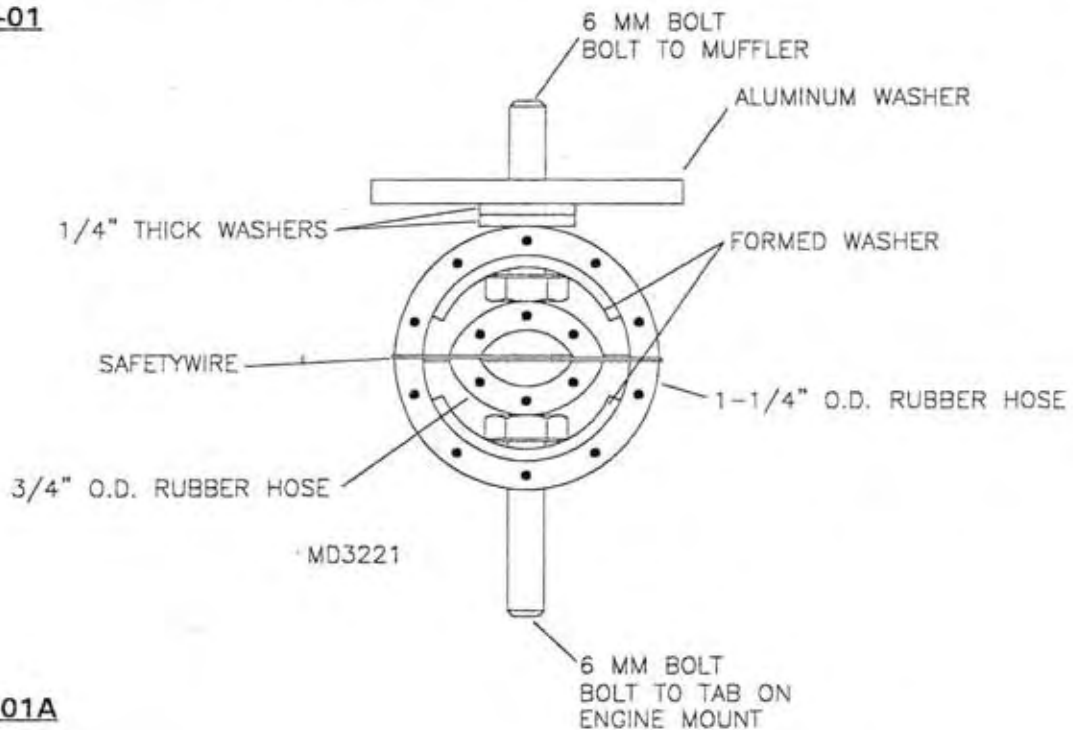


## S-6ES 912 MUFFLER ASSEMBLY & INSTALLATION

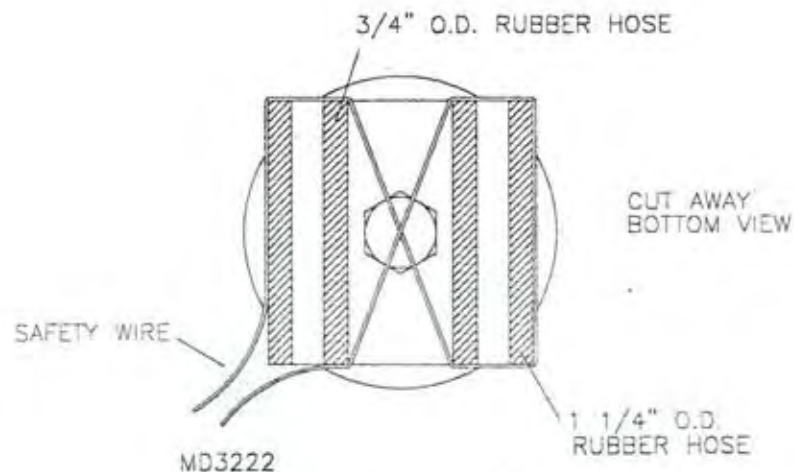
**NOTE:** If you are installing the optional 912 muffler heater system, refer to the options section and install the heater wrap prior to installing the muffler system.

1. Cut two segments, each 1 3/8" long from the 1 1/4" O.D. rubber hose provided in the 912 muffler raw stock kit. Locate the center of each segment lengthwise and drill or punch a 1/4" hole through the top and bottom wall. Install the 6mm bolts and formed washers from the inside of each segment. Refer to the parts drawing and **FIGURE 014-01**. Cut two segments, each 1 3/8" long from the 3/4" O.D. rubber hose. Insert the smaller diameter segments between the bolt heads in the isolator assembly until flush on each end. Safety wire the inner hose in place as shown in **FIGURE 014-01A**. **NOTE:** In order to tighten the bolts, it may be necessary to wait with installing the inner segments and safety wire until after the isolators have been installed on both the muffler and engine mount.

**FIGURE 014-01**



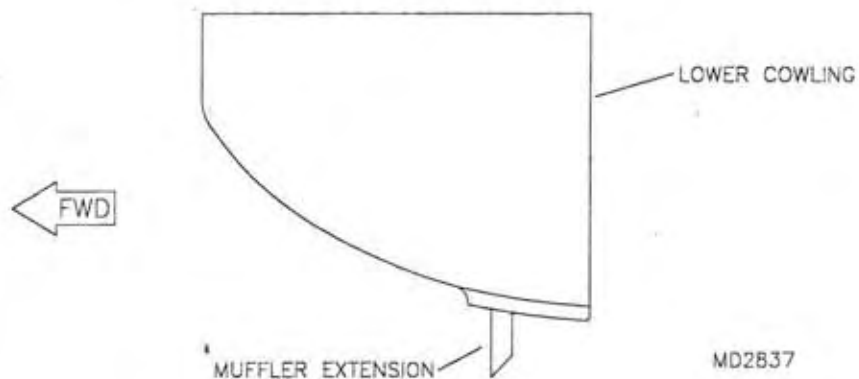
**FIGURE 014-01A**



2. Apply loctite to the threads of the top bolt and attach the rubber isolators, aluminum washers and thick washers to the muffler as shown in the parts drawing. Install the muffler/isolator assembly to the two tabs on the lower legs of the engine mount. Attach the forward sections of the forward and aft manifolds to the engine. Finger tighten the nuts at this time to allow for adjustment of the manifolds. Slip the aft sections of the forward and aft manifolds into place and install all retaining springs. Leave the manifold nuts loose until the cowling has been installed and proper positioning has been verified.

3. Slide the muffler extension over the exhaust port on the muffler until bottomed. Position so that the opening is pointing aft. See **FIGURE 014-03**. It will be necessary to locate and cut an exhaust hole in the bottom cowling for the muffler extension. Locate a #11 hole through the top flange of the muffler extension and through the flange on the muffler. Locate and drill a #30 hole in the hose clamp and install the stainless steel rivet. Install the hose clamp on the muffler extension with the pop rivet extending into the #11 hole in the extension and muffler and tighten.

**FIGURE 014-03**



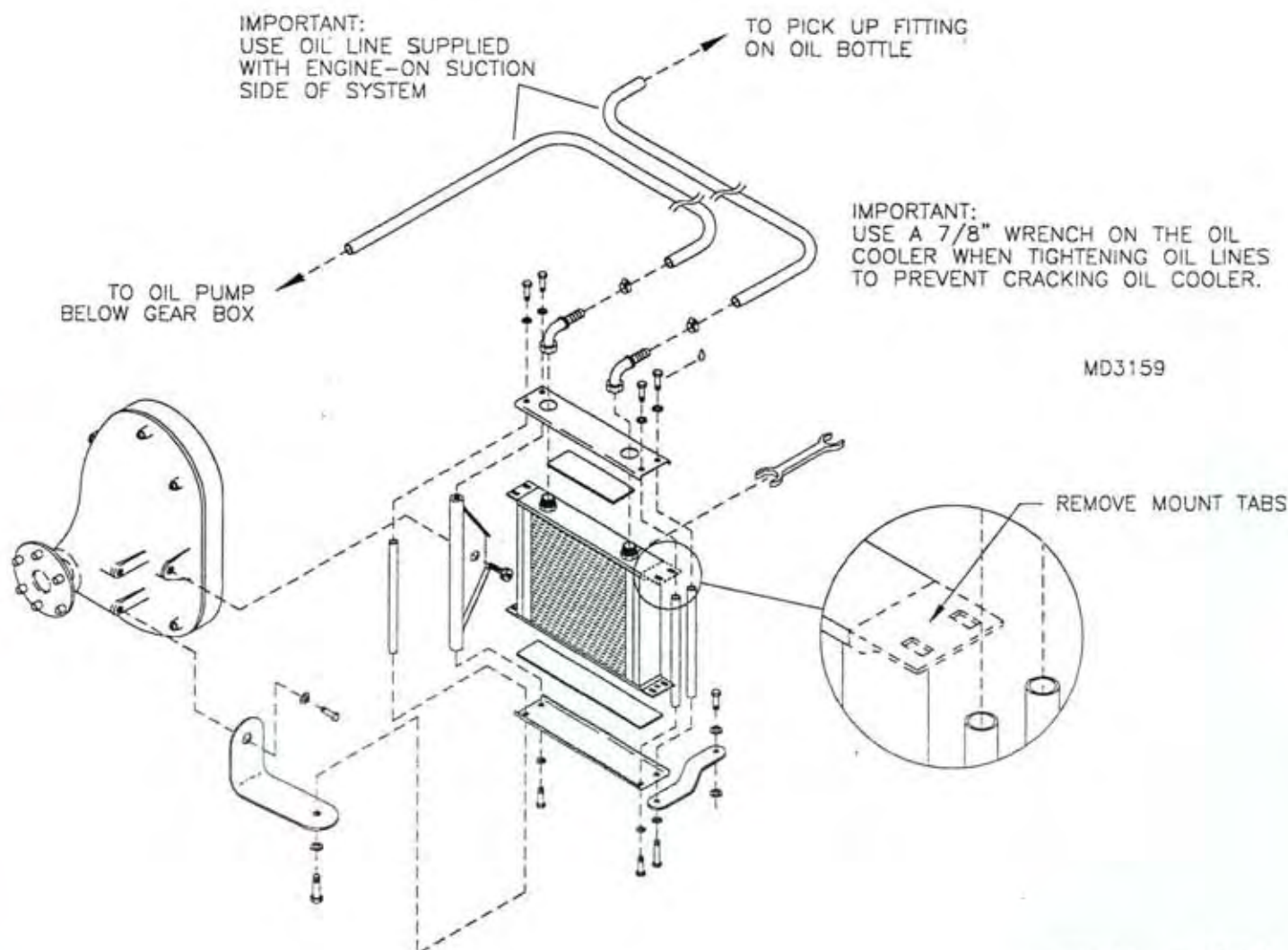
## S-6ES 912 OIL BOTTLE & COOLER INSTALLATION

1. Remove the top from the bottle and inspect the interior for any debris or foreign material. Verify the tightness of the oil drain plug and safety wire. Mark the center and drill a 3/16" hole on the closed end of the attach bushings. Bolt the attach bushings to the mount angles. Slide a screw driver into the opened end of the bushing along the side of the nut to hold the nut while tightening. Clamp the oil reservoir in place on the oil tank aluminum angles. Slide the oil tank/mount assembly onto the stubs on the right hand side of the engine mount. Refer to the parts drawing. Check for clearance with everything in place including the muffler and manifolds. Drill a 1/8" hole through the attach bushings and welded stubs to hold the oil reservoir in place. Make sure to drill the holes at the best orientation for reaching with a rivet gun and rivet in place.

2. **NOTE:** When working with the oil cooler take care not to induce stress or over tighten fittings or bolts. Damage to the cooler may result.

With a bandsaw or hacksaw, remove the mount tabs from the oil cooler leaving a 1/16" lip. Cut to length and install the self adhesive foam to the upper and lower oil cooler mounts as shown in the parts drawing. Apply loctite to bolts and assemble the upper and lower mounts to the cooler using the threaded bushings. Bolt the oil cooler mount to the left side of the gear box as shown in the parts drawing. Attach the bent oil cooler mount to the boss on the forward left hand cylinder head. Refer to the parts drawing. Attach the oil cooler assembly to the mounts on the gear box and engine. See **FIGURE 014-02**.

**FIGURE 014-02**



3. **IMPORTANT:**The pickup fitting is the fitting that enters straight into the top of the oil bottle and **MUST** route to the left hand fitting on the oil cooler. The return fitting is the angled fitting on the oil bottle and **MUST** route to the fitting on the bottom of the engine. Failure to route the oil lines properly will result in engine failure. Install the 90 degree fittings onto the oil bottle and cooler. Use a back up wrench on the cooler and bottle when tightening the fittings.

Note that there are two types of oil line used. It is important to use the correct line in the correct location to prevent oil pump drive pin damage. Cut the oil line to the length required and install with hose clamps. Refer to the parts manual and the Rotax engine manuals. Double check all hose clamps.

Apply anti chafe where necessary and secure all lines.

4. Fabricate the aluminum overflow tube as indicated on the parts page. Attach the overflow tube to the firewall with the conduit clamps. The location of the overflow tube is determined by the builder. Cut to length and install the segment of overflow line from the oil bottle filler neck to the aluminum overflow tube. Secure ends with safety wire or hose clamps.

### PRE ENGINE START UP

5. Prior to starting the engine for the first time, install a new oil filter and fill the oil bottle to the full line on the dip stick. Refer to the Rotax manuals for oil specifications. Remove the top spark plugs on all four cylinders. Verify the mag switch positions to **OFF** (mags grounded). Turn the prop through several revolutions by hand. With the spark plugs out and from the pilots seat, turn the key switch to the start position and crank the engine for several seconds. Check for an oil pressure indication on the gauge. If after several seconds there is no sign of oil pressure, stop cranking the engine. Remove the oil pick up line at the oil bottle. Using a funnel prime the oil line and oil cooler to the pump. Attach the pick up line to the oil bottle and crank the engine. When an oil pressure indication is achieved, stop cranking. Install the spark plugs and start the engine. Watch the oil pressure gauge as the engine starts. At the moment the engine starts, allow 10 seconds for oil pressure to come up. If there is no pressure indication within 10 seconds shut the engine off and repeat the previous procedures. The engine will change sound (quieter) as the oil starts pumping. After running the engine for a few minutes, check the oil level and check for any leaks in the system.

## 503/582 PROPELLER INSTALLATION

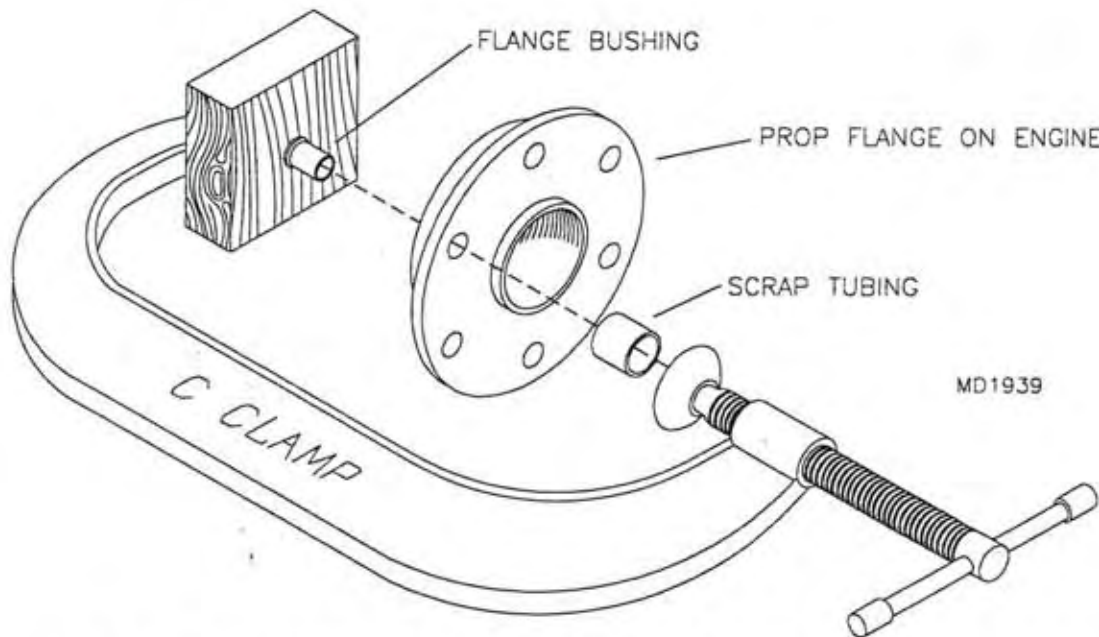
1. Bolt on the propeller (see 503 or 582 engine drawing for correct hardware). **NOTE:** For optional spinner assembly and installation refer to spinner installation. Use 10 ft. lbs. for proper propeller torque. Make sure to install the tensile loc-nuts on the back side of the prop flange. See 582 engine drawing.
2. Check the propeller for balance by inserting a 1" tube through the prop center. Open a bench vise slightly wider than the prop. Position the prop horizontal with tube resting in the vise's jaws. If it is balanced it will remain level for any position it is set at. (Provided your vise is level across the prop and the jaws are smooth.) If the prop drops at tip balance by coating the light tip with a urethane spray varnish. **PLEASE NOTE:** According to the F.A.A. a propeller is still within acceptable balance if the difference is no more than the weight of a nickel. If you tape a nickel to the light end and the other tip still drops, the prop needs balancing.
3. Check prop tracking by placing a marker next to the back of the prop. **HINT:** A 5 gallon bucket works well as a marker. Let the marker touch the back of the prop. Make sure the plane is completely stationary with the wheels chocked and rotate the prop through **WITH THE IGNITION OFF!** If the prop is tracking correctly the other blade should touch the marker also. If tracking is off, loosen the bolts and try re-torquing the bolts until proper tracking is achieved.



## 912 PROPELLER INSTALLATION

1. Insert the flange bushings into the prop flange of the engine from the aft side of the flange. Use a "C" clamp to completely seat the bushings into the flange. Use a small wood piece between the mouth of the clamp and the aluminum flange bushing to protect them from being damaged. **HINT:** A heavy layer of tape on the mouth of the clamp may be used instead of a wooden block. On the forward side of the prop flange use a piece of tubing approximately 1" long over the flange bushings to allow them to seat as the "C" clamp is tightened. See **FIGURE 014-01**.

**FIGURE 014-01**

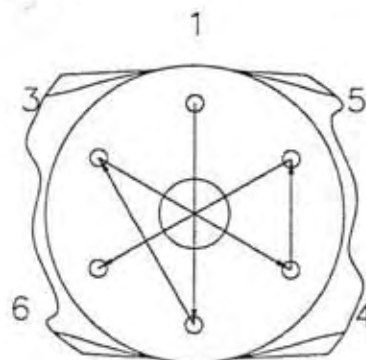
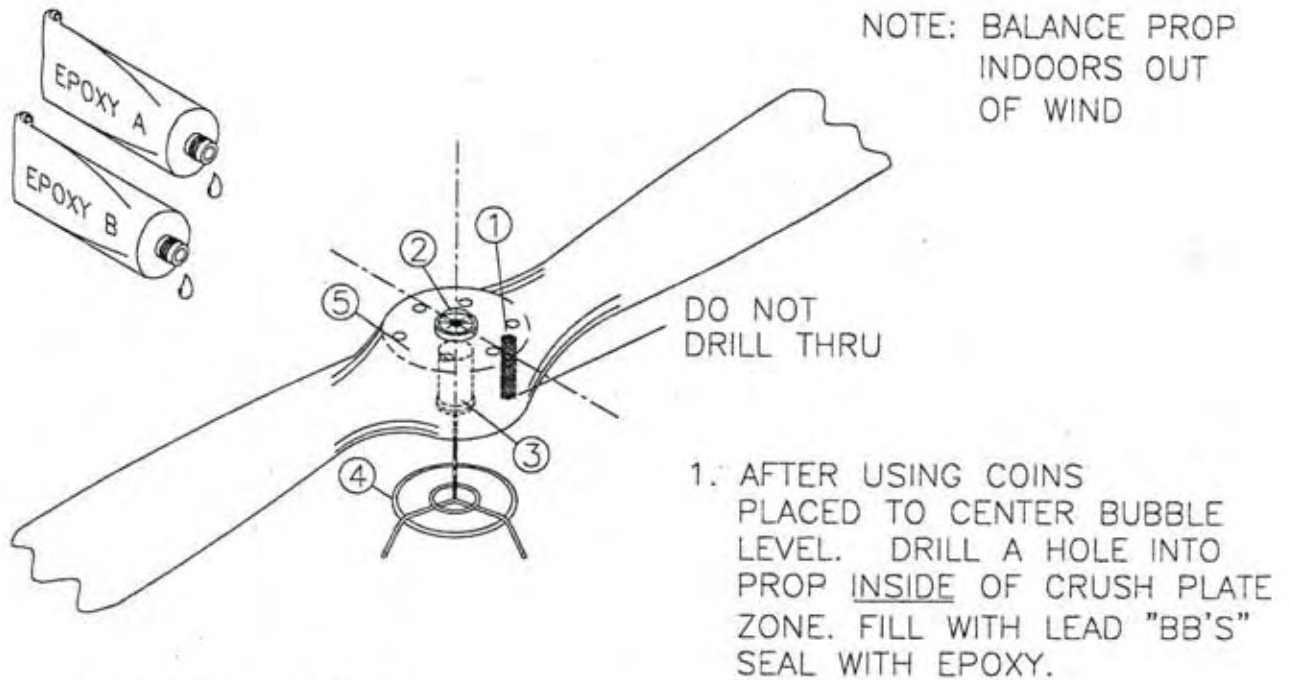


2. Inspect the prop provided for any nicks, crack or dings. The propeller comes from the factory balanced and ready to bolt on, however depending on conditions and how the prop has been stored, it may not be in balance at the time of install. To balance the prop it is best to use a two-axis balancer. These are available from several Aircraft Supply stores. Place the prop on the balancer and follow method to correct balance in **Figure 014-02**.

3. Mount the propeller, as per parts drawing, using the bolts provided. Note the length of the bolts is critical. Use washers to be certain the bolts are not bottomed out on the threads. **DANGER:** If bolts are bottomed out on the threads, the prop is not properly torqued, separation from the aircraft during operation may occur and cause injury or death. Torque the bolt from 175 to 200 inch pounds in the pattern shown in **Figure 014-02**. Re-torque bolts after 5 hours of flight.

4. Check prop for tracking by turning blade into a vertical position and placing an object at the tip. Spin the prop to the next blade and check position. If the position is the same the prop is in track. If not, loosen prop bolts and re-torque until proper tracking is achieved. **HINT:** Start torquing pattern on the blade that is out of track. See **Figure 014-03**. **DANGER:** Track prop with ignition **OFF!!**

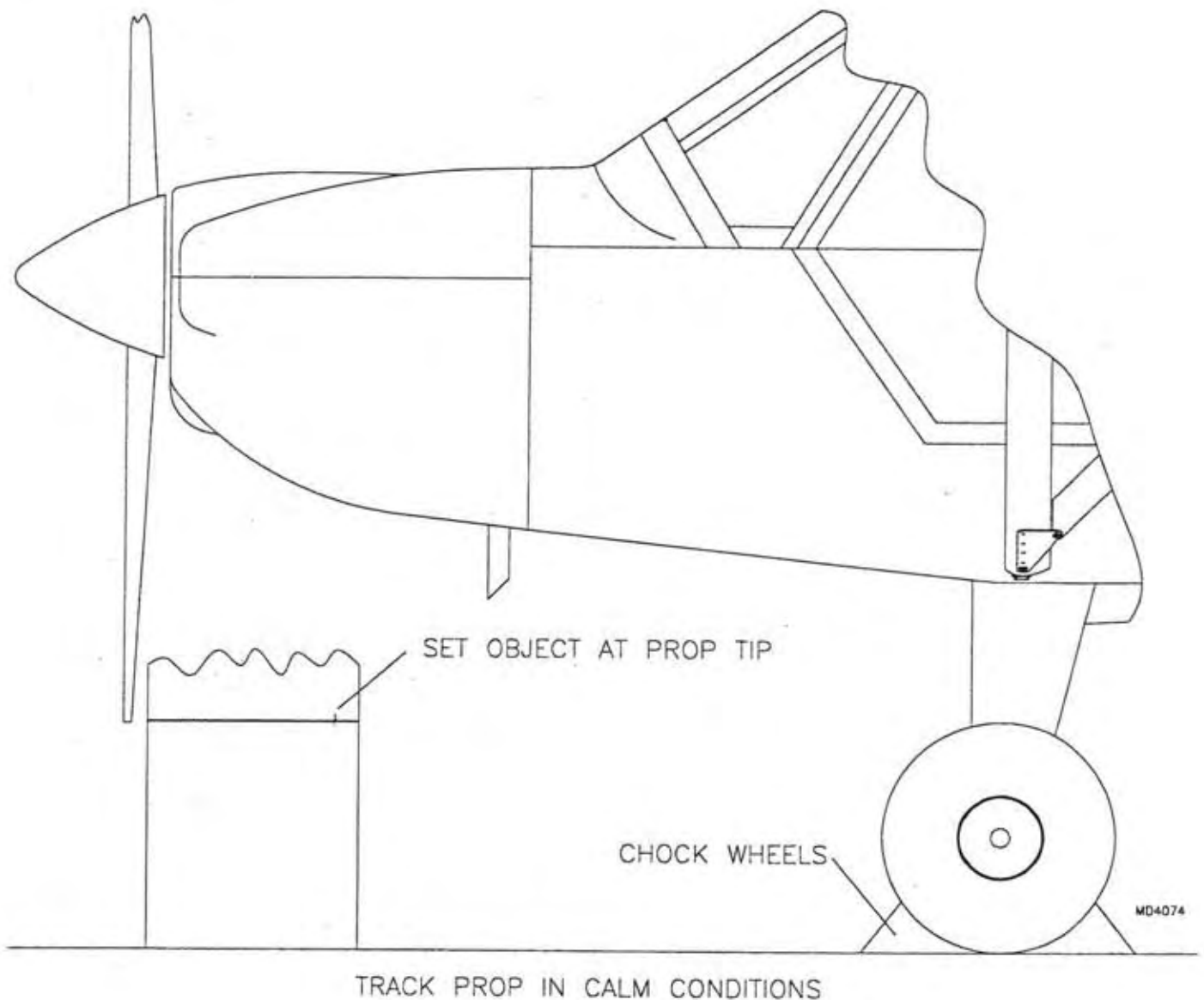
FIGURE 014-02



MD4039

2  
RE-TORQUE BOLTS AFTER 5 HRS. OF FLIGHT

FIGURE 014-03



# IMPORTANT!!

Check propellers torque every 50 hours or after large changes in climate. Wood props will shrink and expand with humidity.

If you live in a climate with large changes in humidity or fly to a different climate, prop torque may change more often.

Failure to maintain proper torque may result in separation of the propeller from the aircraft and may cause injury or death.

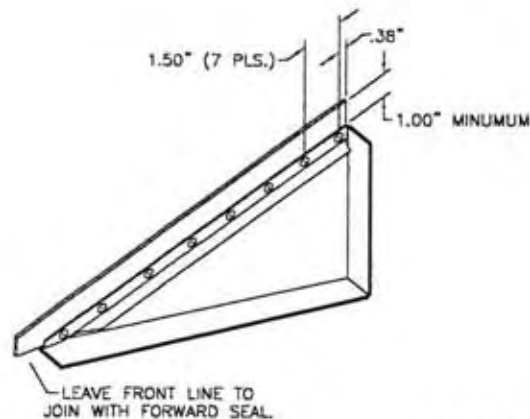
## S-6ES COYOTE II - SLANT COOLING SYSTEM

### GENERAL INFORMATION

The S-6ES features a cooling system that allows installation of an electric start. Incorporated into the radiator mount is the oil injection tank mount. The slant cooling system must be filled and void of air. The location of the filler "T" must be so the cap is above the highest cooling tube on the radiator. This will help avoid air bubbles in filling the system. The system works by "scooping" cooling air through the cooling scoop. This air passes through the radiator and out the bottom hole in the cowling. In reality, you can not push air through a radiator, it must be pulled. On the S-6ES there is a natural high pressure zone where the cowling meets the windshield. We take advantage of this high pressure air by placing a scoop at this point. This incoming cooling air is further pulled through the radiator by the air flowing through the cowling. The two most critical elements to effect cooling performance are coolant level and air flow. Coolant level is something that should be monitored on a regular basis. The effectiveness of the cooling air will be directly effected by the fit and condition of the seals around the radiator edges. If these seals develop leaks, cooling will decrease. Maintain the seals for best cooling.

1. Select all the parts depicted in the parts drawings for the slant cooling system.
2. Install the rubber seals to the radiator mounting angles as shown in **FIGURE 015-02**. Maintain at least 1" of rubber strip **ABOVE** the top edge of the mounting angle.

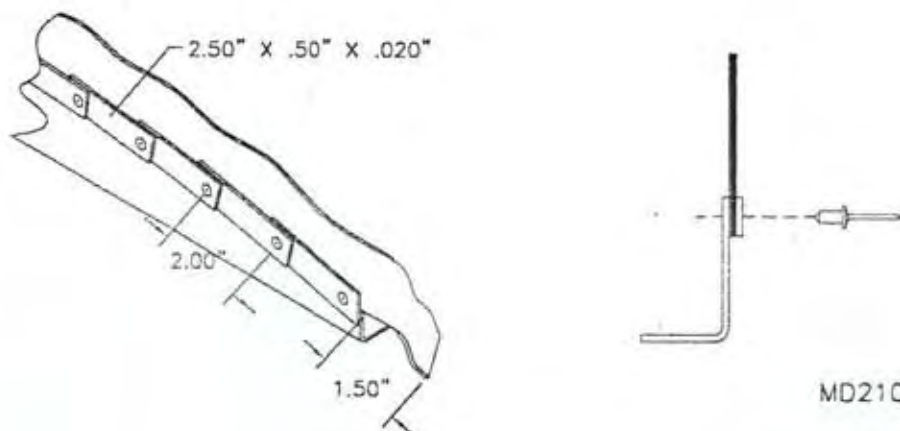
**FIGURE 015-02**



MD210

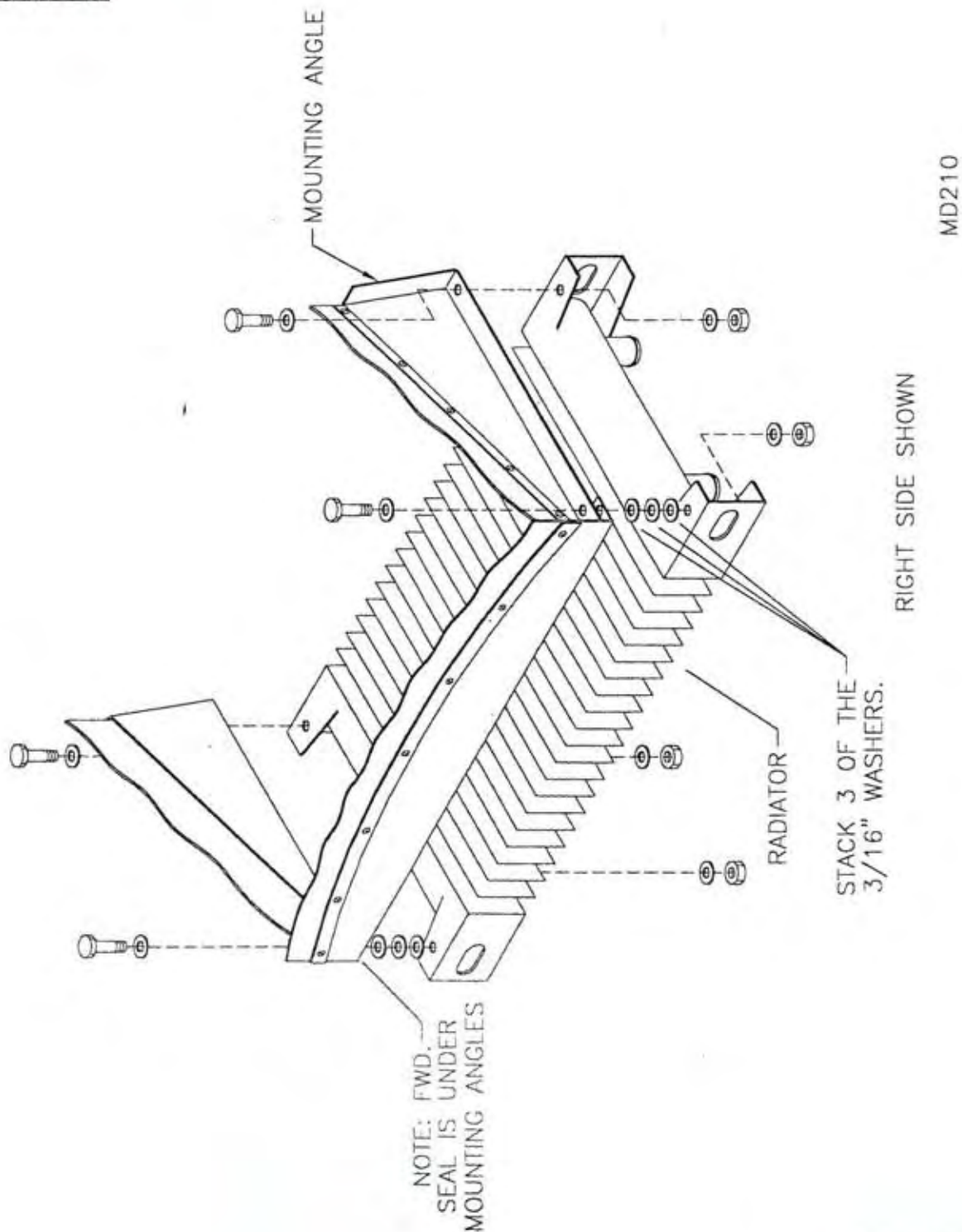
3. Cut the strip of 26" X ½" X .020 aluminum into 2 ½" strips. Cut the entire strip into short segments. Drill a #30 hole in one end of each strip. Cut the 2" rubber strip to 27". Center the rubber strip on the forward seal overlapping the edge ½". See **FIGURE 015-03**.

**FIGURE 015-03**



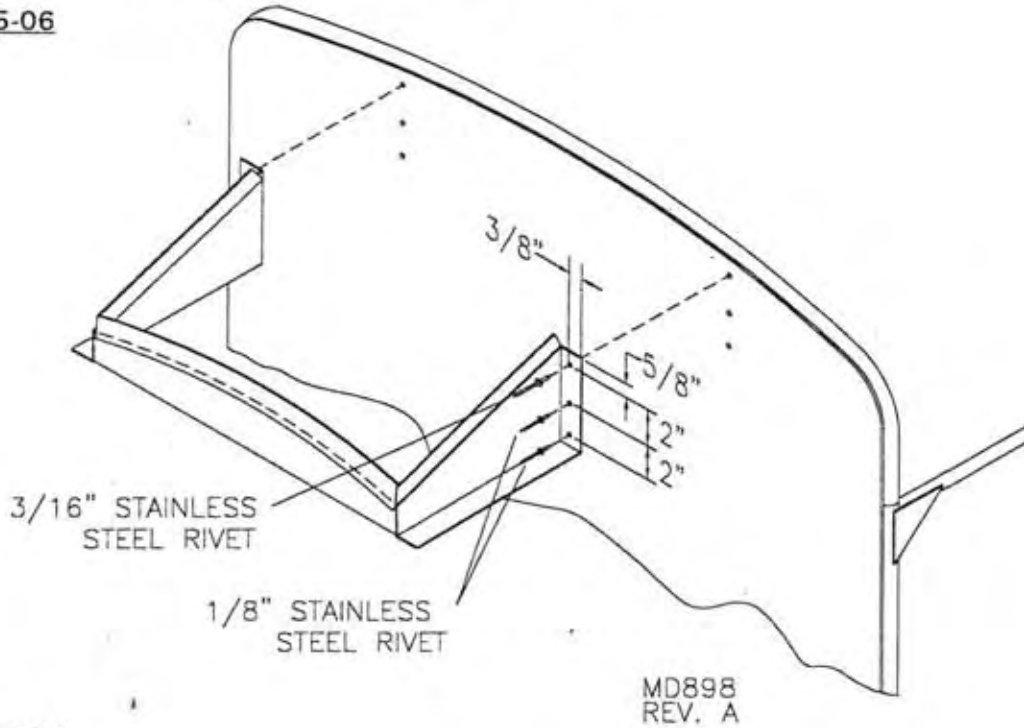
MD210

4. Apply the small foam strip to the bottoms of each radiator mount attach angle. Make sure to place this foam so it seals against the radiator.
5. Refer to the slant radiator mount parts drawing for assembly sequence and bolt the mounting angles and front seal to the radiator. Locate and drill #11 holes through the "EARS" on the radiator to mount the angles and forward seal. These holes are located by putting the mount angles in place and drilling through the corners. Place the forward seal UNDER the mounting angles. Use a stack of (3) 3/16" thick washers to space off from the radiator. See **FIGURE 015-05**. Apply the foam rubber to the BOTTOM of the forward seal. Bolt the baffle to the mounting point on bottom of the radiator, using the washers to space the baffle off if needed.

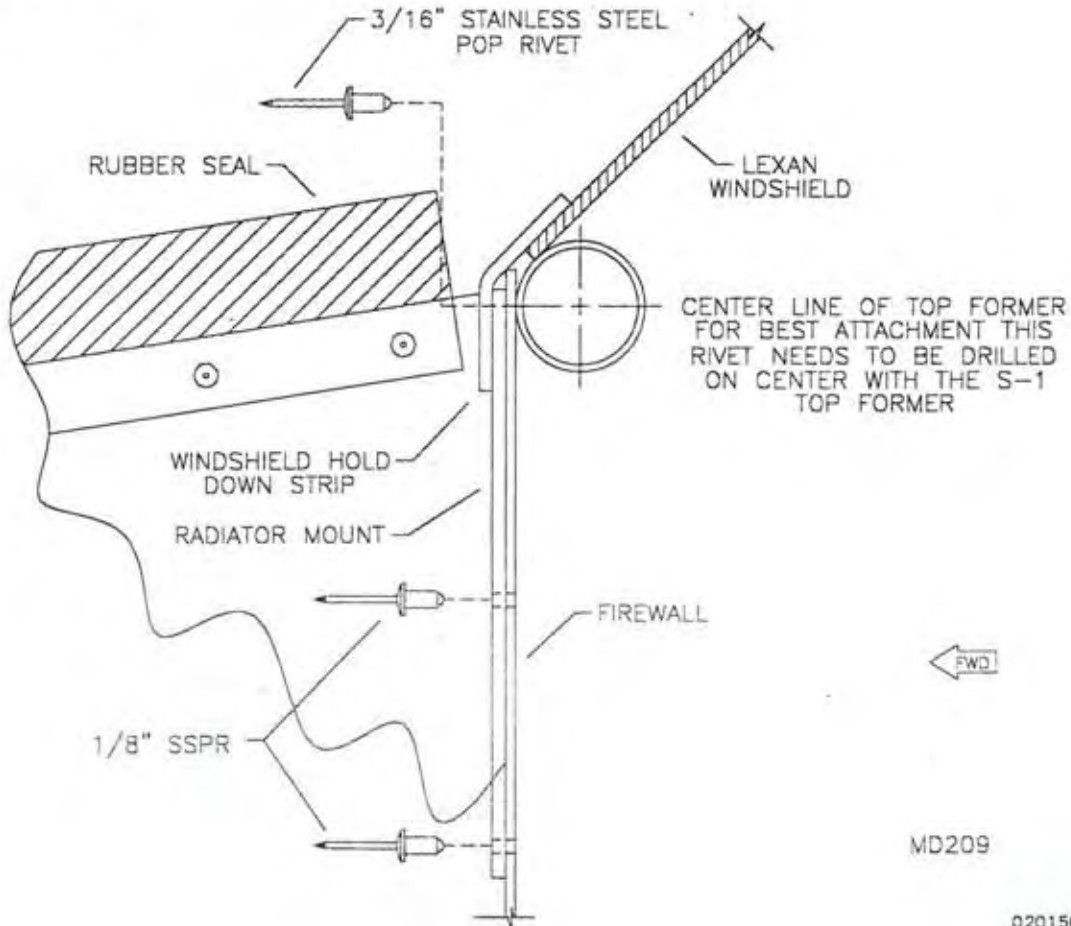
**FIGURE 015-05**

6. The radiator and mount assembly is located on the center of the firewall and the slots made into the windshield hold down strip indicate where the mounts are to slide in. The assembly is located height-wise by the #11 hole in the top of each side mount angle. Locate these holes as per **FIGURE 015-06**. The top #11 hole is critical for it to properly secure and locate the radiator assembly. It must go through the center of the S-1 top former tube. See **FIGURE 015-06A**.

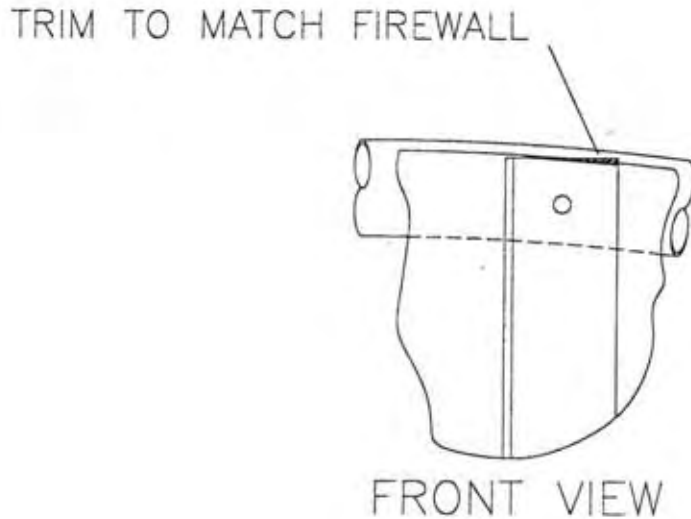
**FIGURE 015-06**



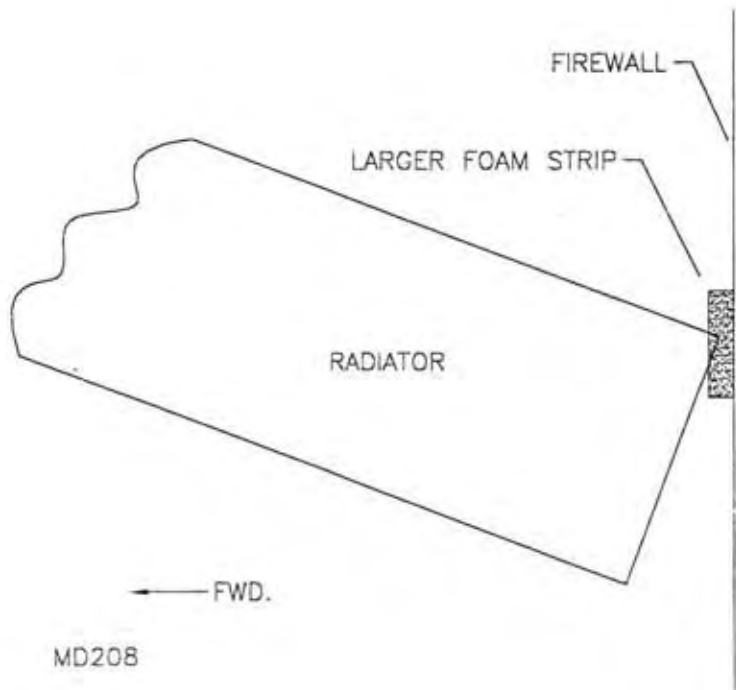
**FIGURE 015-06A**



7. With the radiator assembly properly located on the firewall, locate and drill the two 1/8" holes in each mount angle flange. Do not install any rivets at this time, instead cleco it in place. The top outboard edge of each flange may need to be trimmed to match the contour of the firewall. Refer to **FIGURE 015-07**.

**FIGURE 015-07**

8. Before removing the radiator assembly, mark across the aft **TOP** edge of the radiator. Remove the radiator assembly and apply the larger foam seal on this mark. This is the radiator to firewall seal. See **FIGURE 015-08**.

**FIGURE 015-08**

9. Install the radiator assembly after de-burring the rivet holes. Be careful when setting the rivets. Take care to have all parts flat against each other, especially the top rivet.

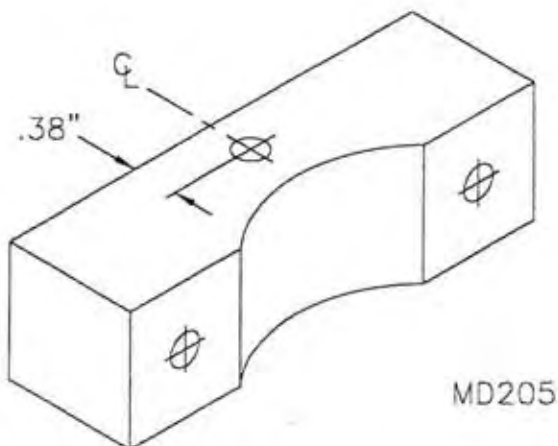
## INSTALLING THE 582 OIL INJECTION TANK

10. Unbolt the radiator from the mount (leave the mount attached to the firewall). Select the parts depicted in the oil injection tank mount drawing. Insert the segment of trim lock around the edges of the hole. Start and stop the trim lock at the aft notch.
11. Insert the tank through the hole with the filler hole placed on the top left. Locate the tank side to side so there is enough room to install the 90 degree withdrawal fitting and clear the edge of the mounting bracket.
12. Use the larger hose clamp to attach the oil tank mounting strap to the tank. Place this clamp and strap assembly approximately 2" from the end so it clears the fittings welded to the end of tank. Bend the mounting straps so the aft flanges fit flat against the firewall. Bend by pinching the strap together at the tank contour bend. Level the tank to the fuselage. Use the main spar carry through for a reference. Once level, mark, drill and rivet with 3/16" stainless steel pop rivets. Bolt the radiator back in place. See photos, page ahead.

## INSTALLING THE FILLER TEE 582/912

13. Locate the gray plastic block that serves as the filler tee mount. Drill a #11 hole through the block as shown in **FIGURE 015-013**.

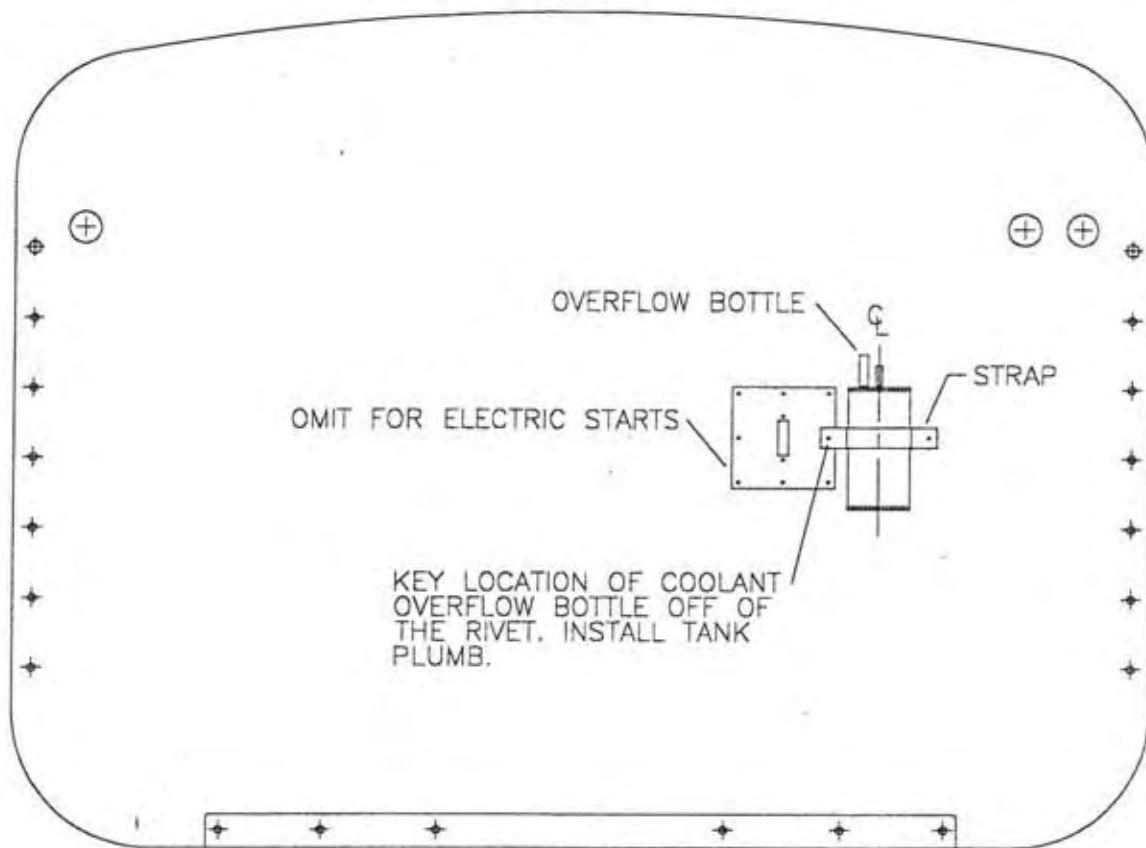
**FIGURE 015-013**



14. Bolt the filler tee mounting block to the left side of the radiator to the hole provided. This hole should be drilled #11 and is about 3" from the front of bracket. Bolt the block on so the groove is on the left side facing out.
15. Select the proper hardware and strap and bolt the filler tee to the mount block. **IMPORTANT:** In order to completely fill the cooling system void of air this filler tee must have the lower rim of the cap bowl **ABOVE** the highest radiator cooling tube. The cooling fins may appear higher than the tank but the cooling tubes are actually lower than the fins. If required move the filler tee forward to raise.
16. Locate the coolant overflow bottle on the firewall as shown in **FIGURE 015-016**. 912 INSTALLATIONS REFER TO ENGINE INSTALLATION SECTION.



FIGURE 015-016



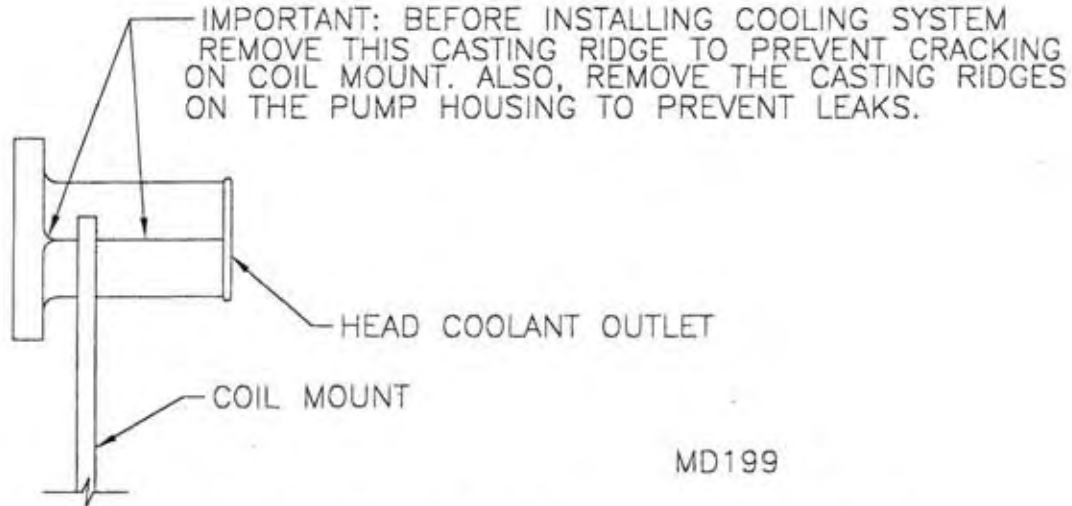
MD197

17. Refer to the parts drawing for the recommended routing for the 582 coolant lines. Double check the fit and routing before cutting. A little extra hose is provided but it will only accommodate small errors. When installing the coolant lines clamps remember to check and re-check all fittings and clamps prior to adding coolant and during pre-flight. Insert the anti-collapse spring into the 21" hose.
18. If installing a 912, it will be necessary to install the "S" shaped radiator hoses on the aft cylinder head coolant fitting of the engine to avoid conflict with the engine mount. See 912 coolant system parts page for hoses. Install on both the right and left aft coolant fittings. Trim hose as required to prevent binding.
19. When installing the top cowl please check for a good fit of the seal between the radiator and cowl.

## COOLANT SYSTEM GENERAL NOTES

- A. Before installing the cooling system remove the head outlet fitting and pump housing on the engine. File and sand the casting ridges smooth and re-install. See **Figure A**.

**FIGURE A**

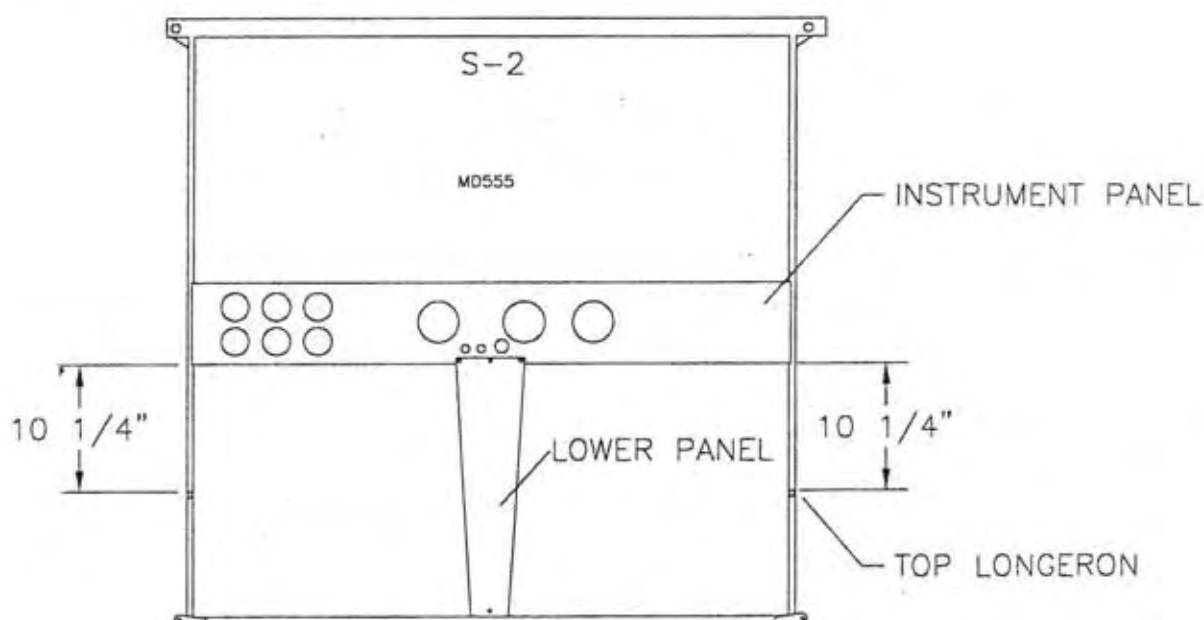


- B. Make sure all hose clamps and fittings are tight prior to adding coolant.
- C. Add a 50-50 mixture of "For Aluminum Engines" anti-freeze and water. Fill through filler tank opening.
- D. Remove the set screw on top of the engine to fill system to engine level. (Apply Loctite to the set screw when re-installing). **HINT:** A piece of fuel line will "screw" right into this hole and allow a no mess overfill.
- E. Open the line at the upper reducer elbow fitting and tilt up nose. (A 5 gallon pail placed under the nosewheel is about perfect). Continue filling the system until coolant runs out at the high most point of this fitting. Re-tighten and install the radiator cap. Lower the nose.
- F. The recovery bottle does not need any fluid. If your system ever gets warm enough some fluid may overflow into the recovery vessel.
- G. Add more coolant after engine break-in. Re-tighten all the clamps and fittings.
- H. Replace the coolant annually and inspect the system for wear. Replace hoses every 2 years.

## INSTALLING THE S-6ES & S-6XL COYOTE II INSTRUMENT PANEL

1. Select the parts depicted in the parts drawing.
2. The instrument panel comes punched, painted and ready to install to the cockpit cage. On the S-3, there are two tabs welded to each side. The instrument panel attaches to the **AFT** side of these tabs. Position the Panel so it is evenly spaced up and down on these tabs and is 10 1/4" from the top longerons. See **Figure 016-02**. Drill through from the front side using the tabs as locators for the holes. Attach the center panel to the upper panel's aft side and the aft side of the tab welded to the cockpit's bottom. Use three evenly spaced 1/8" stainless steel pop rivets to attach the top of the panel. Use a single 3/16" aluminum pop rivet to attach the lower panel at the bottom.

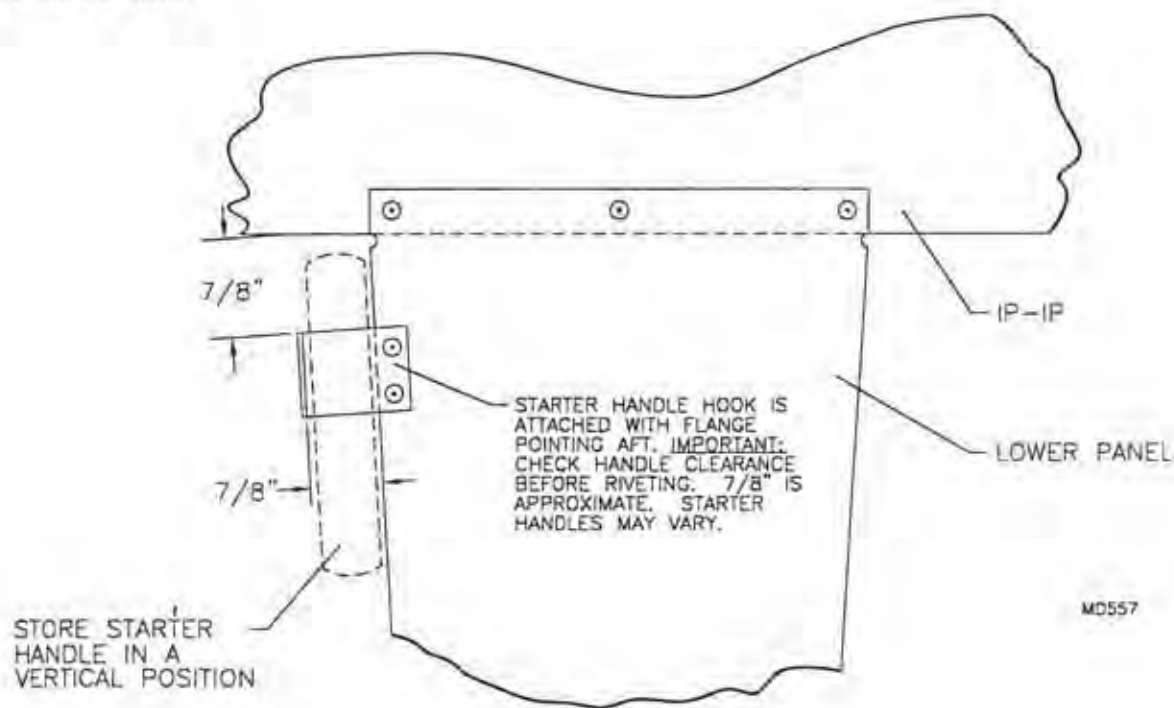
**FIGURE 016-02**



3. The top panel dust cover is positioned on the panel's front side and drilled #30 through the panel's top and bottom flanges. Use the pre-drilled holes in the panel to locate the holes in the dust cover. Make sure the dust cover is inserted fully into the panel. After drilling through the dust cover with the #30 drill, remove the dust cover and drill out the holes in the flanges of the top instrument panel 3/32". After all the instruments are installed replace the dust cover and install the screws.
4. The lower panel dust cover installs the same way as the top panel cover.
5. To access the top instrument panel it is not required to remove the dust cover, only the top screws. Be careful not to scratch the windshield when removing the top screws.

**912 INSTALLATION SKIP THIS STEP**

6. Locate, drill and rivet the starter handle hook as shown in **Figure 016-06**. The starter handle stows in the vertical position. Check the fit before drilling and riveting. Check control stick travel to be sure it does not interfere with the handle.

**FIGURE 016-06**

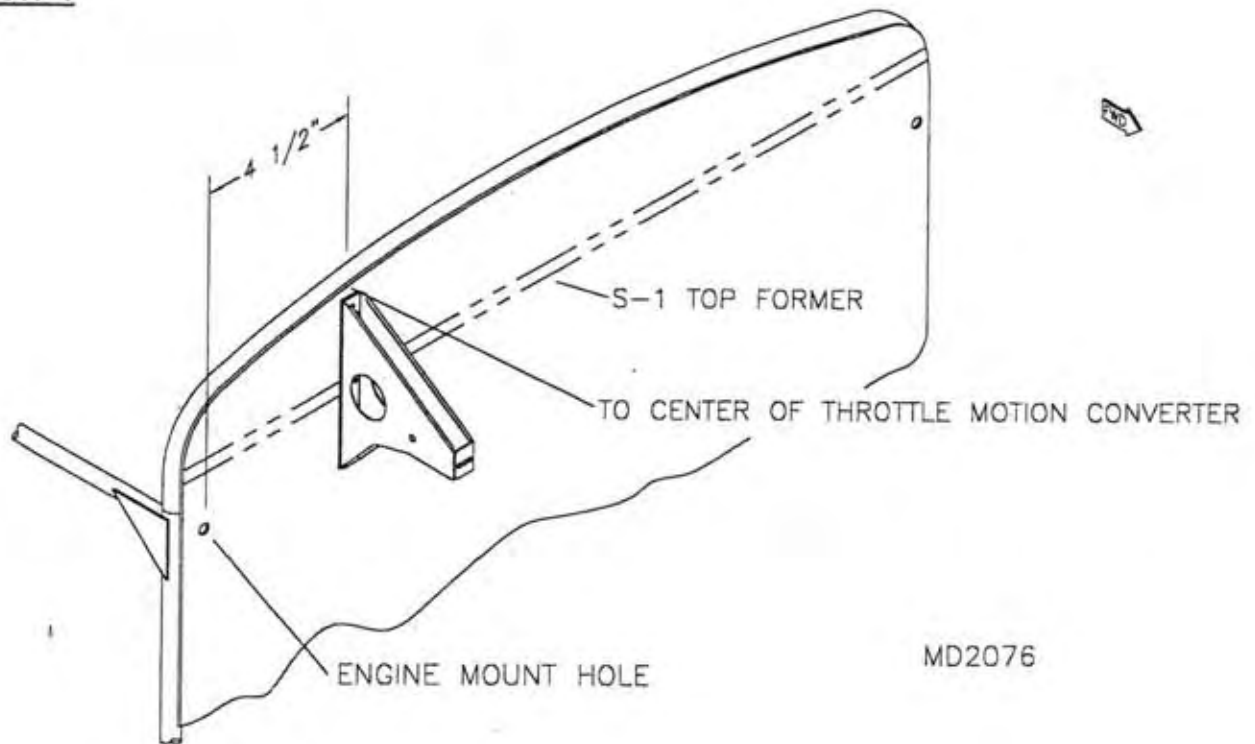
## BATTERY BOX INSTALLATION

1. Locate the parts shown in the parts manual.
2. Drill one hole in the support angles and the corresponding hole in the side plate to #30 and rivet the support angles to the side plate. Chase drill through the second hole of the side plate and support angle and rivet. Refer to the parts drawing.  
Position one side of the side plate flush with the mount plate. Using a #30 drill bit and using the mount plate as a guide, transfer drill through the three side holes in the mount plate into the side plate. Rivet the side plate to the mount plate through the #30 hole(s) only. Slide the battery into the box and pull the opposite (loose) side of the side plate in tight to the battery. Using the mount plate as a guide transfer drill through the mount plate into the side plate with a #30 bit and rivet.
3. Install the cushioned clamps as shown in the parts drawing. Note the orientation of the cushioned clamps. Position the battery box for best placement. Mark the mount hole locations onto the box using the clamps as a guide. Drill the mount holes to #11 and bolt in place.
4. Install the cushioned clamps as shown in the parts drawing. Note the orientation of the cushioned clamps. Position the battery box for best placement. Mark the mount hole locations onto the box using the clamps as a guide. Drill the mount holes to #11 and bolt in place.
5. Connect the battery as shown in the parts drawing. Use the four gauge wire to make the cables, cut the negative cable long enough to go from the battery to the right socket bolt. Route the positive cable up the right side of the fuselage and connect it to the starter solenoid.

## S-6ES COYOTE II - 503/582 THROTTLE & MOTION CONVERTER

1. Assemble the Throttle Motion Converter as shown on the parts drawing. Drill the spacer bushings #30. For 503 equipped aircraft locate the motion converter as shown in **Figure 017-1**. For 582 equipped aircraft mount the converter to the right side of the radiator mount. Secure to the mount with (2) CCPQ-42 rivets. Drill #30 and rivet. Drill 1/4" through the firewall and install the Adjustor Ferrule.

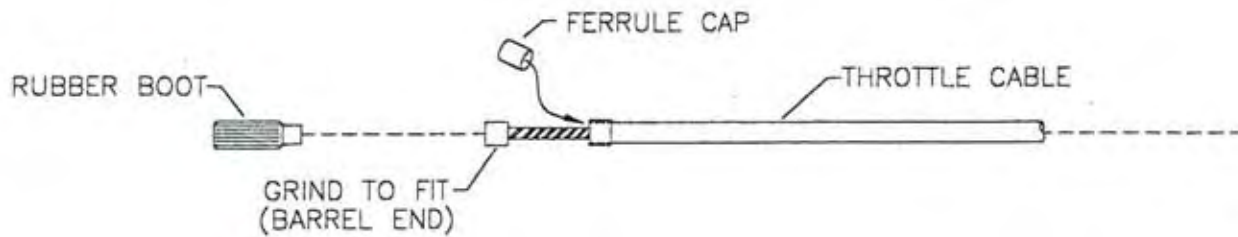
**FIGURE 017-1**



MD2076

2. Install the Throttle in the lower panel. Route the Throttle to the adjustor ferrule in the firewall. **IMPORTANT:** *No sharp turns are allowed that will bind the cable.* Mark the throttle housing for trimming. Pull the throttle out of the throttle body until the wire's free end is past the cut off mark. Cut off the excess housing. **IMPORTANT:** *Closely examine the housing where you've cut it. A clean cut is a must...the metal coil can rub the wire and cause it to break.* Push the throttle wire back out. Safety-wire the housing to the adjustor.

3. To hook up the throttle cable, unscrew the carb's top plate. Take care not to let the spring inside jettison the plate onto the floor. Remove the spring and cap and place aside. Look closely at the slider...see the white plastic fitting on the bottom? Underneath this should be the needle-clip that holds the fuel-metering needle. **IMPORTANT:** *Be sure when re-assembling, the needle-clip is UNDER the white plastic.* Close examination will reveal where the cable terminates, but before hooking up the throttle cable, slide the Cable Ferrule Cap (a small metal cup shaped piece) over the cable and over the end of the cable housing. Now slip the little rubber boot over the end. See **Figure 017-03**. During re-assembly, note that the position where the throttle exits the cap is not on center. Position the cap so the cable is directly over its slider position.

**FIGURE 017-03**

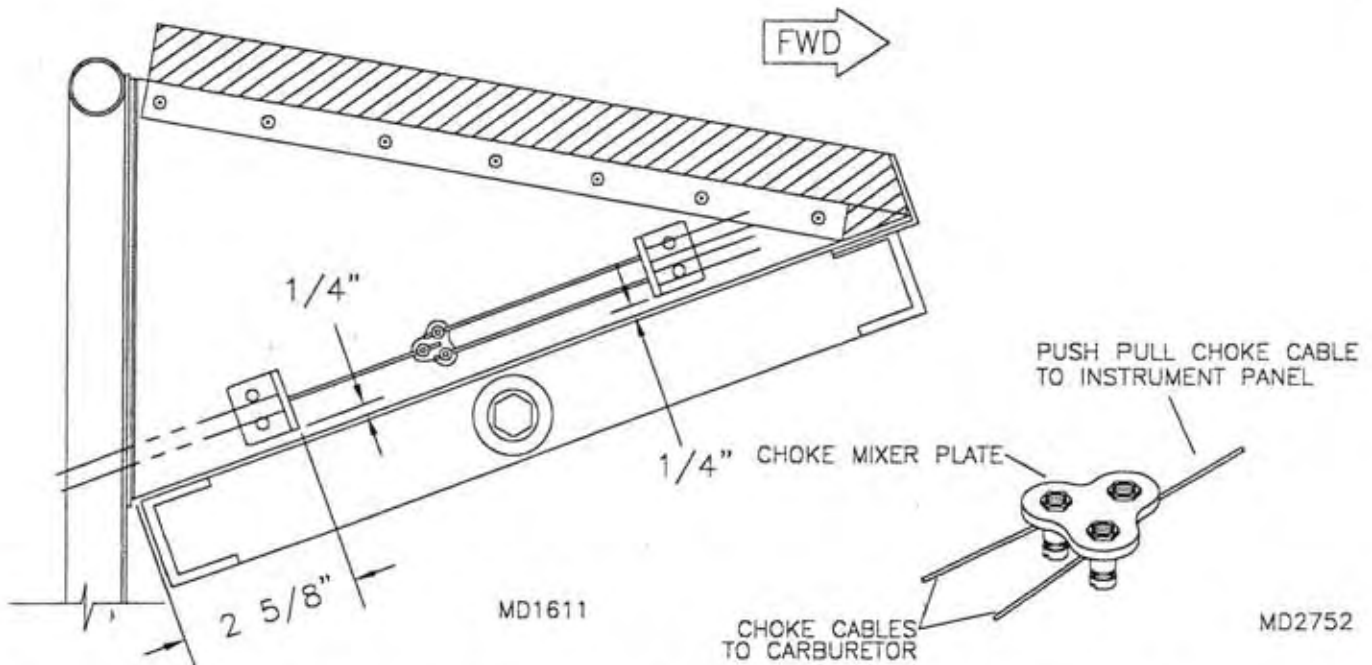
4. Pull on the free end of the cable to seat the housing into the fitting on top of the carb plate. Now route the cables as follows: Out the top of the carb, curving back to the Throttle Motion Converter, through the Adjustor Cable Ferrules in the converter and through the 3/8" spacer bushing. Double check to see that everything is curving gently. **IMPORTANT:** *No sharp turns are allowed that will bind the cable.* Check to see if the housing is into the carb's top plate fitting. Mark the housing where it needs to be cut to length at the converter. Pull the housing away from the carburetor so the cable's free end will be inside past your cut off mark. Cut off the excess housing and push the cable out. **IMPORTANT:** *Closely examine the housing where you've cut it. A clean cut is a must...the metal coil inside the housing can rub the cable and cause it to break.* An unclean cut of the throttle cable housing can also result in sticking of the controls due to the added friction. Slip a Cable Ferrule Cap over the cable and housing. Safety wire the housing to the Adjustor Cable Ferrules.

5. The panel mounted throttle is designed to be at full throttle when pushed forward toward the panel. Adjust the Wire Stop Screws as needed to attain full throttle when the throttle is pushed all the way forward. **IMPORTANT:** *Be sure to synchronize the carbs on dual carb systems.*

## S-6ES COYOTE II – 912/912S THROTTLE

1. Install the single and dual cable retainers to the right side of the radiator mount as shown in **Figure 017-01**. Drill 1/4" through the firewall, in line with the single cable retainer. Install the Cable Conduit Ferrules in each retainer. Drill a #40 hole next to each ferrule for safety wiring of the throttle cables.

**FIGURE 017-01**



2. Install the Throttle in the lower panel. Route the Throttle through the firewall to the conduit ferrule. **IMPORTANT: No sharp turns are allowed that will bind the cable.** Mark the throttle housing for trimming. Pull the throttle out of the throttle body until the wire's free end is past the cut off mark. Cut off the excess housing. **IMPORTANT: Closely examine the housing where you've cut it. A clean cut is a must...the metal coil can rub the wire and cause it to break.** Push the throttle wire back out. Safety-wire the housing to the retainer.

3. Slip the Throttle Cable through the Allen Screw on the carburetor throttle arm. Hold the Allen Screw and tighten the nut to retain the cable. Route the cable through the adjustable ferrule in the support arm on the carb. Slip a Cable Ferrule Cap over the cable and housing. Route the cable and housing from the adjustor ferrule to the conduit ferrule in the dual retainer. **IMPORTANT: No sharp turns are allowed that will bind the cable.** Mark the cable housing for trimming. Pull the housing away from the cable until the cable free end is past the cut off mark. Cut off the excess housing. **IMPORTANT: Closely examine the housing where you've cut it. A clean cut is a must...the metal coil can rub the wire and cause it to break.** Push the housing back on. Slip a Cable Ferrule Cap over the cable and housing. Safety-wire the housing to the dual retainer.

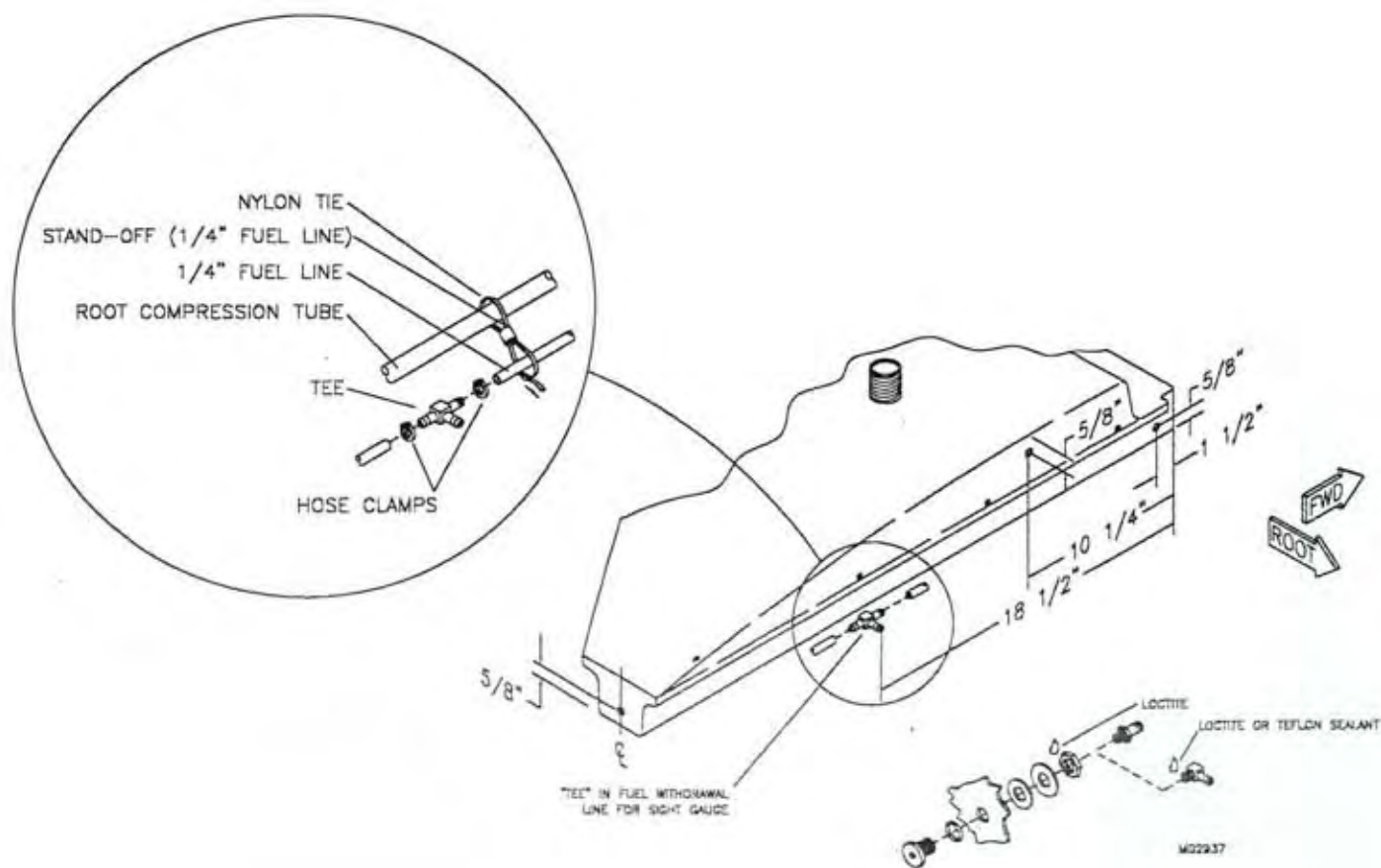
4. The panel mounted throttle is designed to be at full throttle when pushed forward toward the panel. Adjust the Wire Stop Screws in the Mixer Plate as needed to attain full throttle when the throttle is pushed all the way forward. **IMPORTANT: Be sure to synchronize the carbs using the full throttle stop on the carb as a guide.**

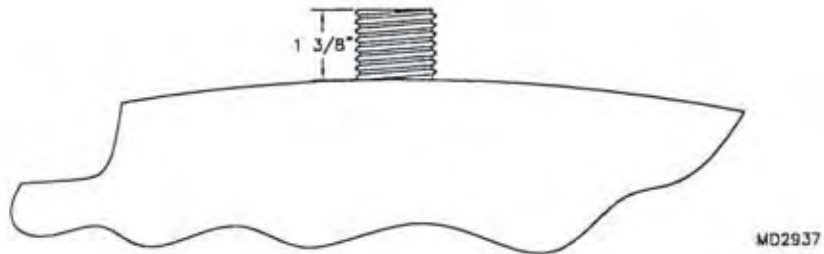


## WING TANK FITTING INSTALLATION

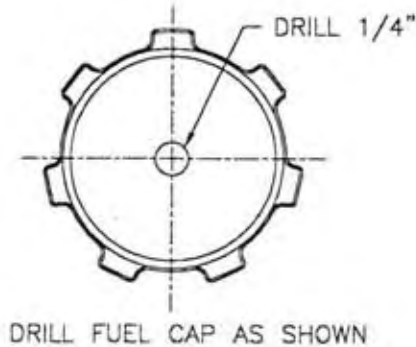
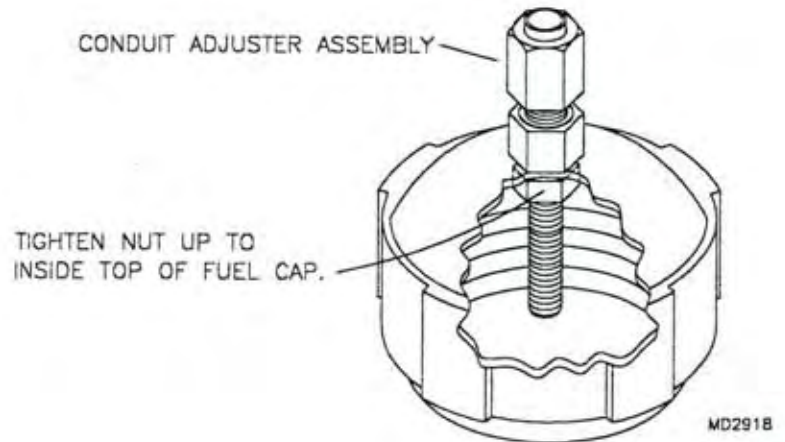
1. Locate the fuel tank(s). See the parts list for part numbers.
2. The fuel tanks are leak tested from the supplier and guaranteed leak proof. You, however, may want to perform a leak test, especially after installing the fittings. If you desire, fill the tank(s) with water and let it sit for approximately 48 hours. Locate three (3)  $\frac{1}{2}$ " diameter holes for the fuel fittings at the locations shown in **Figure 018-02**. **IMPORTANT:** These measurements are very critical for proper clearance of the Tank Withdrawal Fitting. **HINT:** A UNIBIT<sup>®</sup> step drill makes a very clean, accurate hole. All fittings are located on the inboard side of the wing tank (see parts manual for orientation). Debur all holes. **NOTE:** Mark on the tank the position for the  $\frac{1}{4}$ " Tee (lower sight gauge attachment). Secure the withdrawal line and Tee to the Root Compression Tube when installing the tank in the wing. **HINT:** Place a wire in the fitting hole and up through the filler neck, slip a withdrawal fitting and o-ring on the wire, then pull the fitting to the hole with the threaded portion out of the tank. Holding the fitting with the threaded portion extended out of the tank, thread on the rubber washer,  $\frac{1}{2}$ " washer and nut with Loctite. Remove the wire. **NOTE:** Use a  $\frac{1}{4}$ " Allen wrench to hold the tank withdrawal fitting while tightening the nut. **HINT:** Hold the metal washer with needle-nose vise grip to prevent rotation while tightening the nut. Apply sealant to the straight or 90-degree fuel line fittings, and screw into the tank withdrawal fitting until snug. **CAUTION:** Do not tighten to the point the tank withdrawal fitting turns in the tank. Mark and trim the filler neck to a length of  $1 \frac{3}{8}$ " from the top of the tank using a hacksaw or cut-off wheel and file smooth. See **Figure 018-02A**. **CAUTION:** Remove **ALL** shavings and loose debris from the interior of the tank. Use a vacuum to assist in removal.

**FIGURE 018-02**

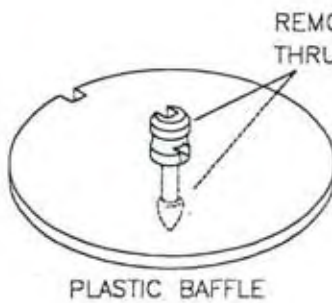
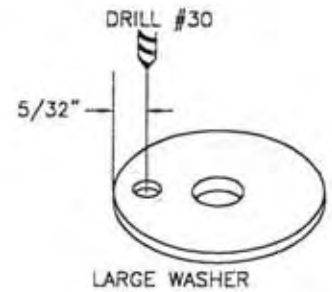
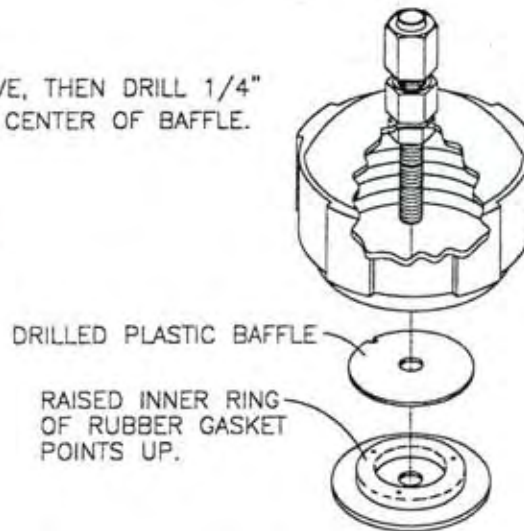


**FIGURE 018-02A****FUEL CAP/VENT ASSEMBLY**

3. Remove the rubber gasket and plastic baffle from the fuel cap. The plastic baffle will "snap" out of the fuel cap. A screwdriver works well for the removal. Locate and drill a 1/4" hole in the center of the fuel cap as shown in **FIGURE 018-03**. Install the conduit adjuster ferrule into the fuel cap. Apply a small drop of Loctite and install the 1/4" plain nut and tighten to secure the ferrule into the cap. See **FIGURE 018-03A**.

**FIGURE 018-03****FIGURE 018-03A**

3a. With a side cutters or file remove the attach nipples from the plastic baffle. See **FIGURE 018-03a**. Drill a 1/4" hole in the center of the plastic baffle and install into the fuel cap over the adjuster ferrule stem. Drill a 1/4" hole in the center of the rubber gasket and install into the cap. Note the orientation of the rubber gasket. Drill the 1/4" large wood washer as shown in **FIGURE 018-03a-A**. Assemble the bead chain to the bead chain retainer sleeve. Install the bead chain and retainer sleeve into the #30 hole in the large wood washer. Install the washer and bead chain into the fuel cap. Install the 1/4" shear nut on the adjuster ferrule stem and tighten.

**FIGURE 018-03a****FIGURE 018-03a-A**

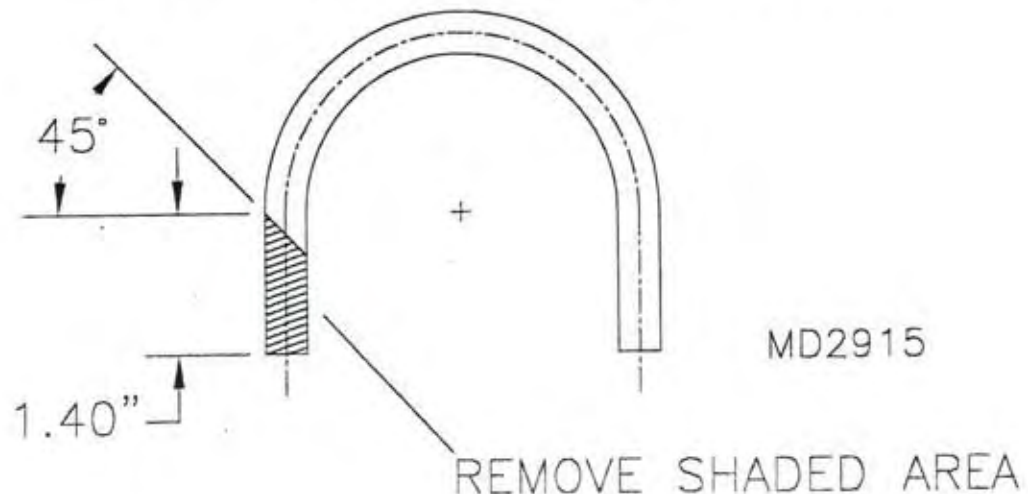
MD2918

3b. Install the bead chain end coupling onto the bead chain. Find the center of the plastic retainer and drill a #30 hole. Using the brass-backing washer, rivet the plastic retainer to the bead chain. Refer to the parts drawing.

3c. Modify the vent tube as shown in **FIGURE 018-03c**. Install the vent tube into the adjuster ferrule. Install the fuel cap assembly onto the tank and tighten. Position the vent tube so that the 45-degree angle is pointing forward (into the slipstream) and tighten the ferrule cap to secure the vent tube.

**FIGURE 018-03c**

MODIFY VENT TUBE (KPFS0020)



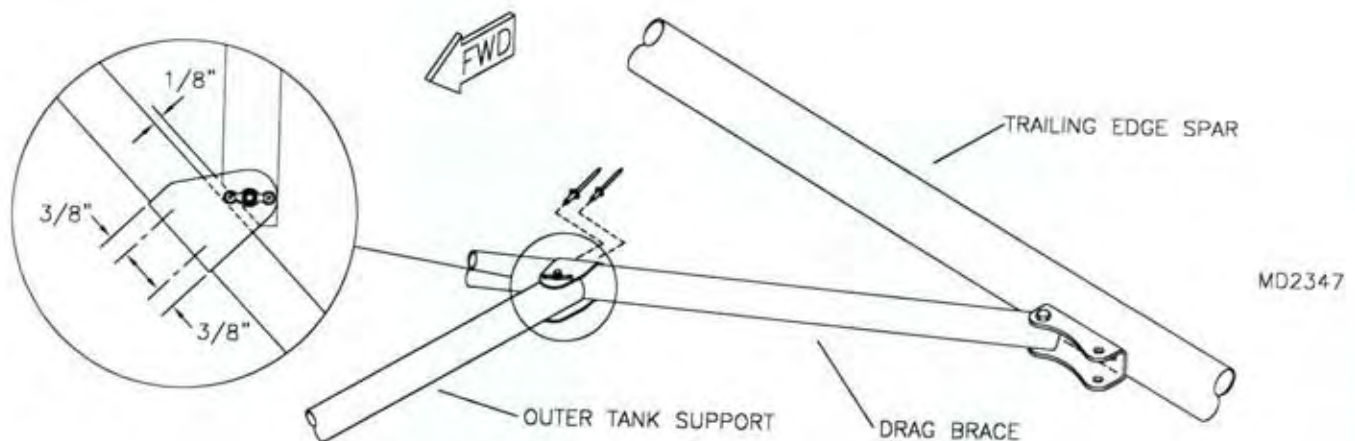
## S-6ES FUEL TANK MOUNTING

4. Locate the parts shown in the parts manual. Make sure that the tank assembly steps shown have been completed before installing fuel tanks into the wing. Locate the pre-located hole, 17" from the inner S2-SAB, on the trailing edge of the Leading Edge Spar. Drill #11, and rivet an S2-SAB to the spar. This will locate the S2-SAB, which holds the outer tank support in place. Install single-ear nut plate to S2-SAB; refer to parts drawing.

### STANDARD WING

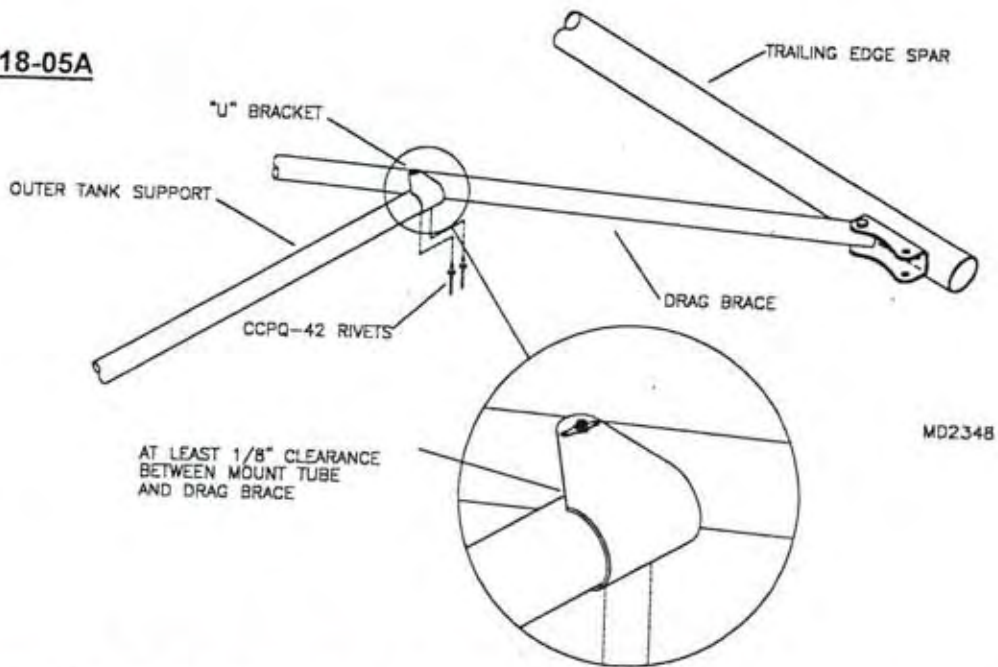
5. Place tank on wing frame, leaving 1/8" gap between leading edge spar and tank; also allow 1/8" gap between inner compression tube and tank. Bolt forward end of outer tank support to S2-SAB. With tank in position, pull outer tank support parallel to tank, maintaining 1/8" gap. Trim outer tank support diagonally to accommodate drag brace; take care not to trim tube short. Locate U-bracket to drag brace, install nut plate and bolt. Drill two #30 holes through aft side of U-bracket and rivet U-bracket to brace. See **Figure 018-05**.

**FIGURE 018-05**

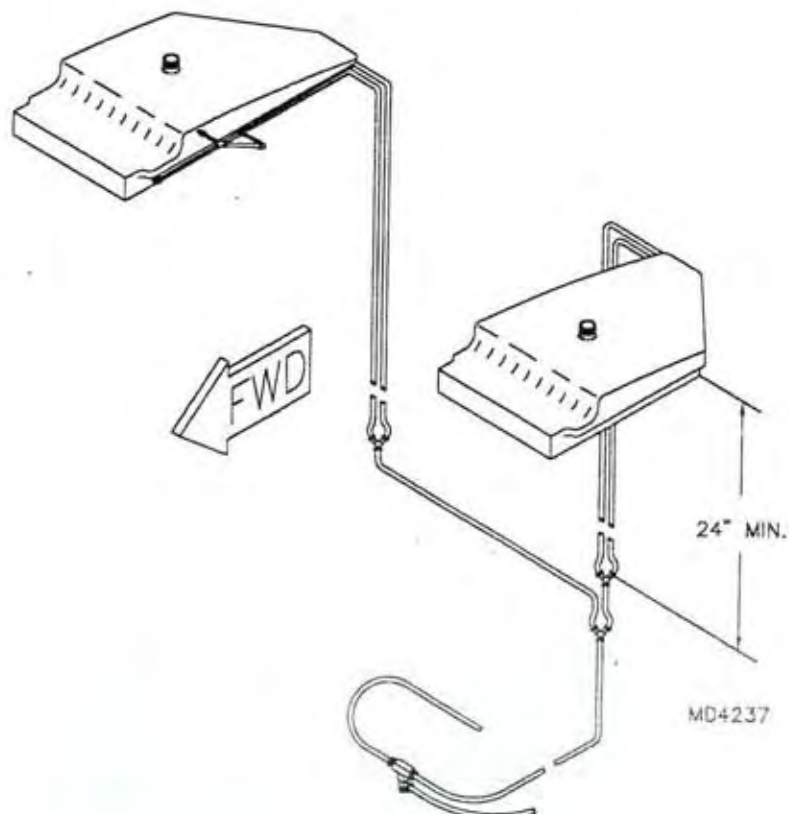


### 116 WING

Place tank on wing frame, leaving 1/8" gap between leading edge spar and tank; also allow 1/8" gap between inner compression tube and tank. Bolt forward end of outer tank support to S2-SAB. With tank in position, pull outer tank support parallel to tank, maintaining 1/8" gap. Trim outer tank support diagonally to accommodate drag brace; take care not to trim tube short. Locate U-bracket to drag brace, transfer-drill #11, install nutplate and bolt to U-bracket. Drill two #30 holes through underside of U-bracket and rivet to tank support. See **Figure 018-05A**.

**FIGURE 018-05A**

6. Bolt the wing tank mount brackets to the fuel tank using the hardware shown. Notice that the bent bracket bolts to the aft of the fuel tank on the inboard side. Using the tank mount brackets as a guide, drill #30 the brackets and inner compression tube. Install the rivets shown in the parts manual. Repeat this for the outer tank support. Once tank installation is complete, apply Loctite to the bolts that hold the tank in place. Repeat for the second wing tank. Route the fuel lines as shown in **Figure 018-6**. **IMPORTANT:** Allow fuel line to extend at least 24" below wings, before installing the "Y" connector. **HINT:** For now, only tape the fuel lines in position. This will ensure proper routing without wasting zip ties. Zip tie lines in position during final assembly once satisfied with the routing. Be sure to route the fuel lines out the wing near the trailing edge of the wing. This will allow the wing to easily fold.

**FIGURE 018-06**

## **GENERAL GUIDELINES FOR FUEL SYSTEM ASSEMBLY**

- (A). Route lines to curve without kinks or chafing against structure. Use anti-chafe material as needed.
- (B). Hold lines in place with the plastic zip ties provided. **DO NOT** over-tighten and kink lines.
- (C). Keep lines away from sources of heat and electricity.
- (D). Safety wire or clamp all connections including the primer lines.
- (E). Firewall exit of the fuel line should be on the side the carburetor is on\*. Use rubber grommets to protect fuel line.
- (F). **Operational Note:** Fill tanks to within 1/2" of bottom of filler necks. This will reduce overflow.
- (G). Remember water doesn't flow uphill and neither does fuel. Avoid running lines with routes above fuel source.
- (H). Apply blue Loctite to all fittings.

\*DOES NOT APPLY FOR 912 INSTALLATION

## S-6ES COYOTE II WINDSHIELD ASSEMBLY

1. Collect all the parts shown on the part pages for the windshield. Extra care should be taken when working with Lexan. Lexan scratches easily and as much as possible of the protective plastic should be left in place until the aircraft is ready to be flown. The windshield will require some minor trimming. Lexan can be easily trimmed with aviation snips or by scoring and snapping off the piece to be trimmed. A sanding block with 80 grit paper works well for dressing up trimmed Lexan.

### WINDSHIELD CARE

Lexan windshields scratch very easy. To get a longer service life from your windshield and other Lexan surfaces, we recommend a soft terry cloth and a cleaner made for plastic. We use a product called Brillianize. It is available from RANS or any large aircraft supply company. The big no-no is never dust off a windshield unless you have sprayed on some sort of fluid. Your dry dusting action will readily cut millions of fine scratches into the glazing, dimming its clear optics.

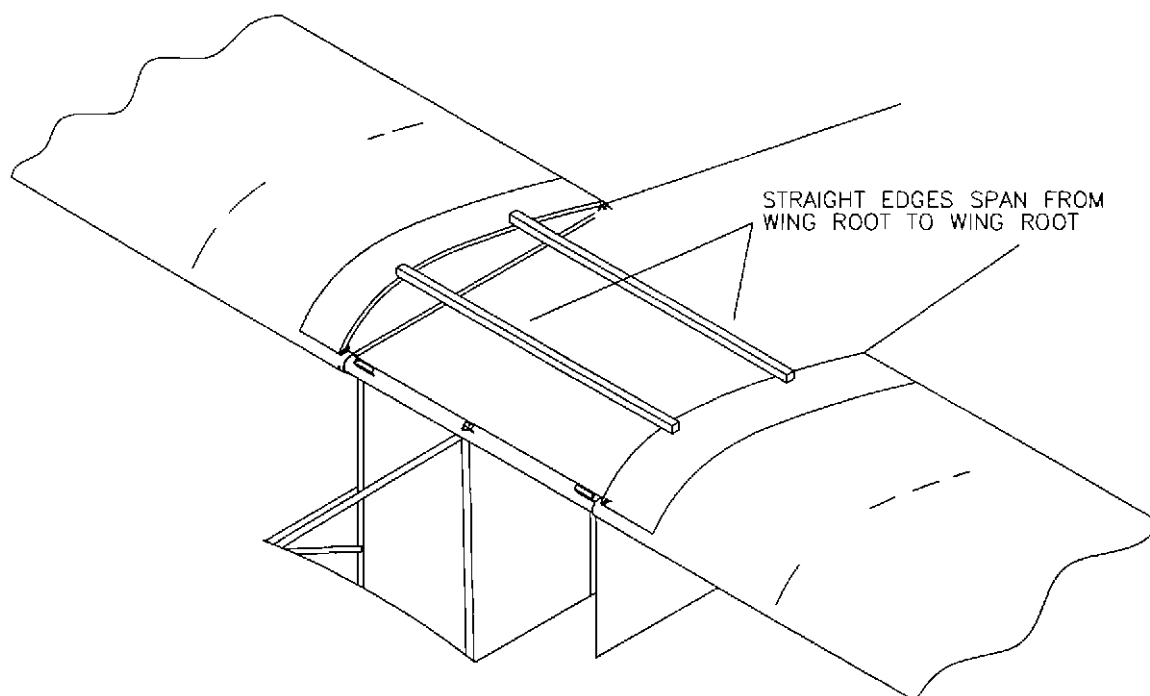
#### **CAUTION: NEVER ALLOW FUEL TO COME IN CONTACT WITH LEXAN.**

If fuel is spilled on Lexan, spray with water or cleaner immediately to lessen the chance of crazing damage.

**NOTE:** *The wing structures must be complete (can be covered and painted) and attached to the fuselage prior to installing the windshield/skylight.*

2. With the wings attached to the fuselage, position two straight edges from wing root to wing root as shown in **FIGURE 019-02**.

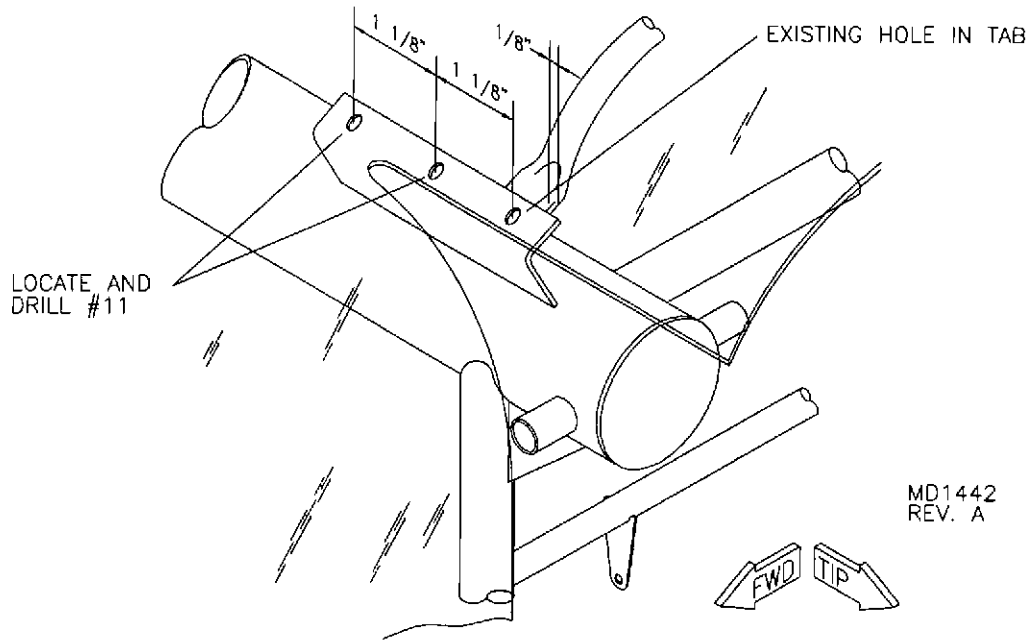
**FIGURE 019-02**



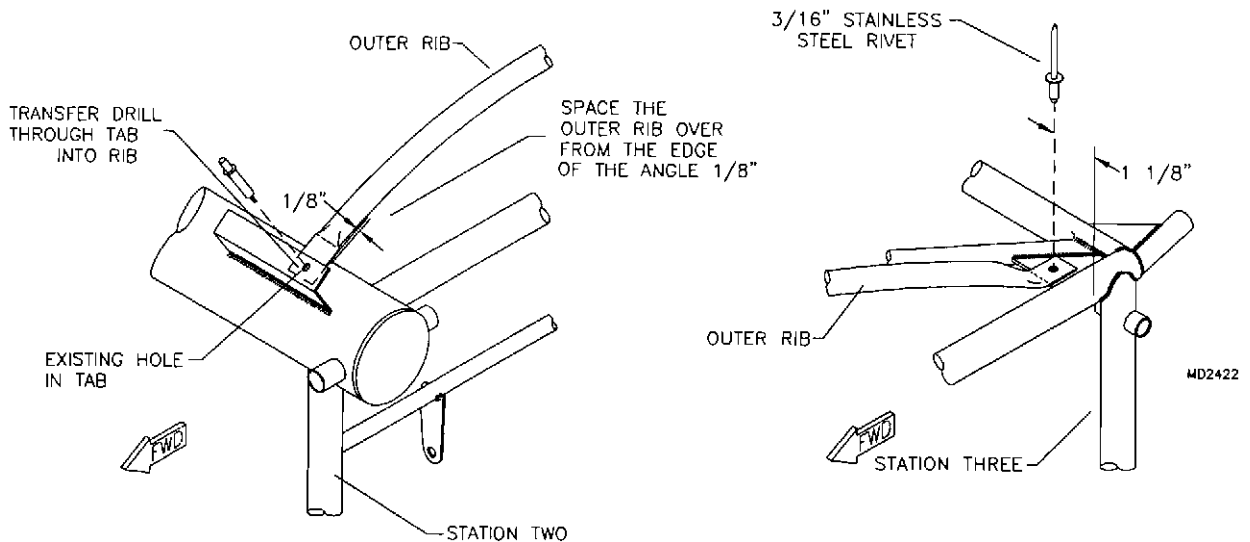
MD3354

- Drill the windshield tabs located on the leading edge spar carry through as shown in **FIGURE 019-03**. The outer skylight ribs mount to the underside of each tab through the outboard hole. Slip each rib into position and transfer drill through the carry through tab into the rib and Cleco in place. Refer to **FIGURE 019-03A**. The center rib is positioned under the center tab on the leading edge spar carry through and slips over the center tab on the Station 3 top cross tube. Position the center rib and transfer drill through the forward tab into the rib and Cleco. Locate and drill a #11 hole in the center of the flattened portion on the aft end of each outer rib. Push the aft end of each rib forward until they uniformly contact the straight edges. Some tweaking of the ribs may be required. With the ribs contacting the straight edges transfer drill through the rib into the steel gusset on the fuselage and Cleco. **NOTE: Do NOT rivet the forward ends of the outer ribs until after installing the windshield.** Refer to **FIGURE 019-03A**.

**FIGURE 019-03**

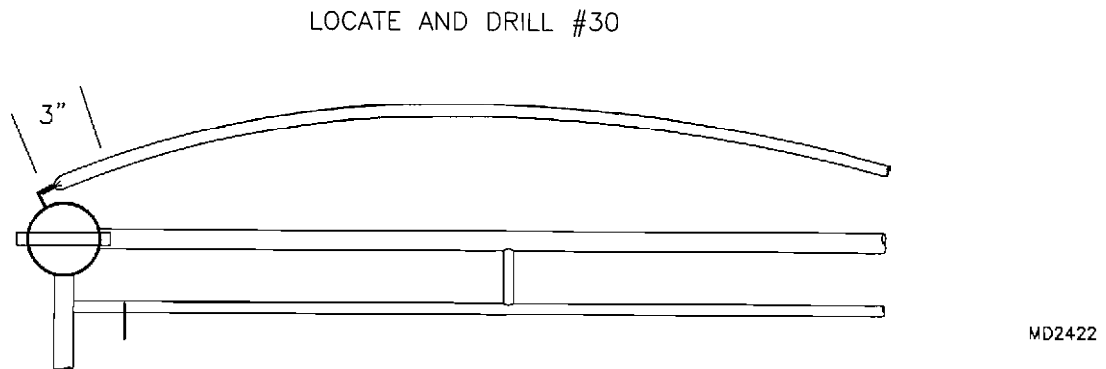


**FIGURE 019-03A**

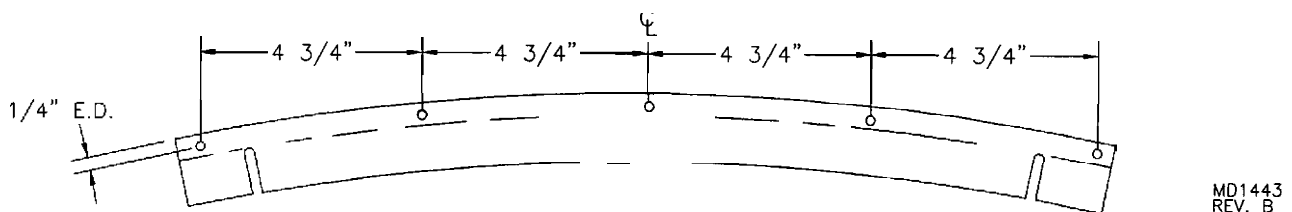




4. Remove the center rib from the aft mount tab. Hold the rib under the tab and push forward until contacting the straight edges. Transfer drill through the tab through the rib. Locate and drill a hole in each rib, on top centerline, as shown in **FIGURE 019-04**. **HINT:** Draw a length of aluminum across the top of the ribs to mark the top centerline. Mark the entire length of the ribs. Do **NOT** drill completely through the ribs! Reposition the center rib over the tab and rivet both ends. Rivet the aft end of the outer ribs. **NOTE:** Do **NOT** rivet the forward ends of the outer ribs until after installing the windshield.

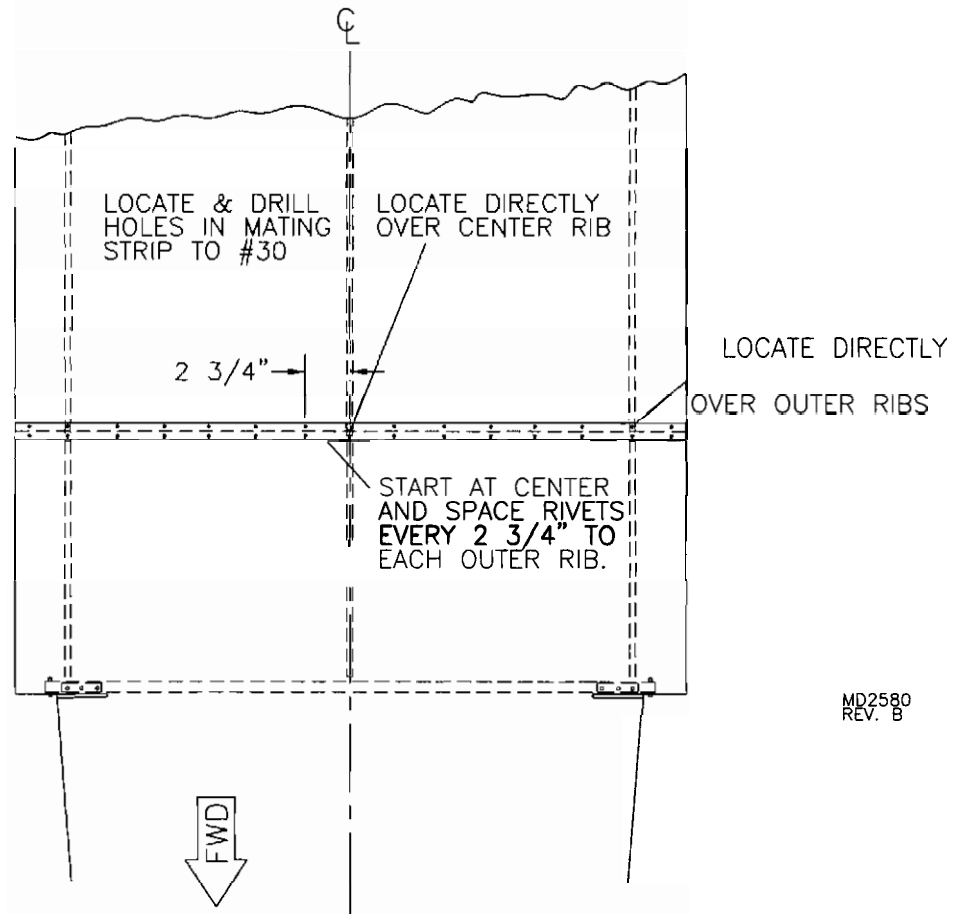
**FIGURE 019-04**

5. **NOTE:** Refer to the firewall section and install the windshield hold down strip. Mark and drill the top flange of the windshield hold down strip as shown in **FIGURE 019-05**.

**FIGURE 019-05**

6. The windshield and skylight panels are joined together with two mating strips. Pre-drill the mating strips as shown in **FIGURE 019-06**. Note that the center set of holes should be located to pick up the center rib, as well as the corresponding holes to the outer skylight ribs. Lay the windshield and skylight on a clean flat surface. Butt the skylight to the windshield. Center the top and bottom mating strips on the windshield and skylight seam. Using the pre-drilled holes as a guide, transfer drill through the mating strips and windshield and skylight. Cleco as you go. With all holes drilled, remove the mating strips and deburr. Drill out the windshield/skylight holes to #28. The mating strips may be painted or left as is. Run a small bead of silicon along the holes in the mating strips and rivet the strips to the windshield and skylight. **IMPORTANT:** Do **NOT** rivet in the rib area. A fillet of silicon seal may also be applied to the mating strip, windshield/skylight junction.

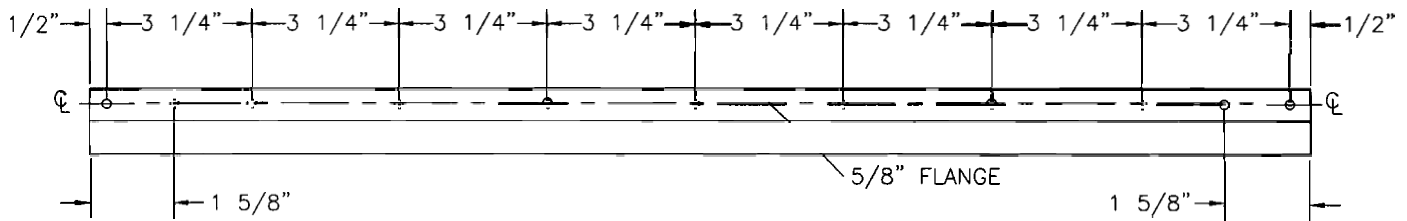
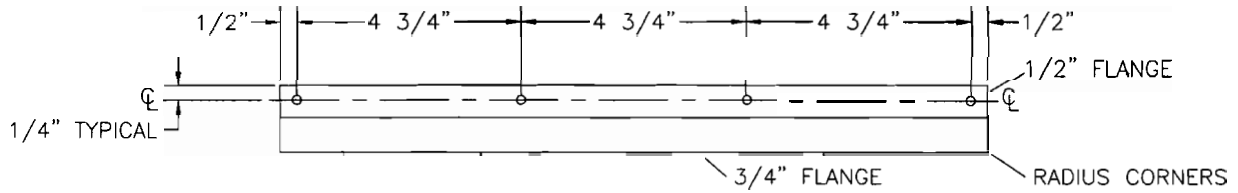
**FIGURE 019-06**



MD2580  
REV. B

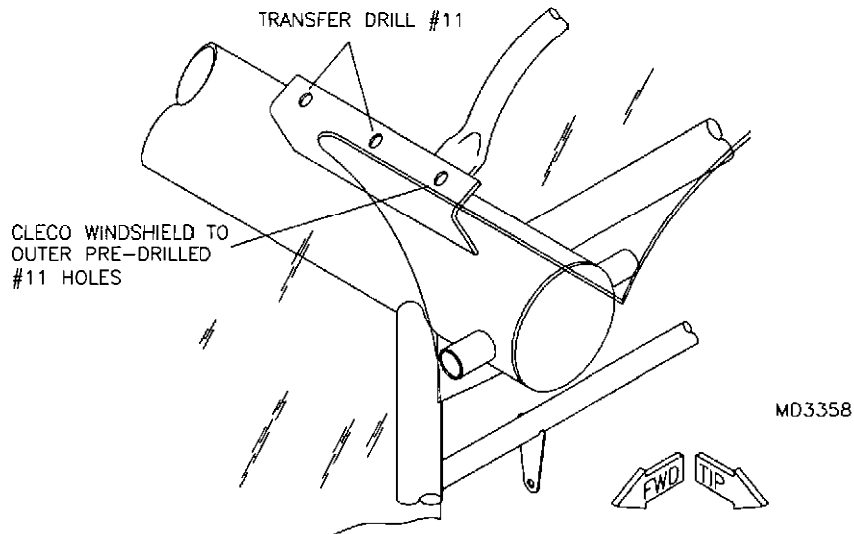
7. Lay out and pre-drill #30 holes in the "Z" strips as shown in **FIGURE 019-07**.

**FIGURE 019-07**

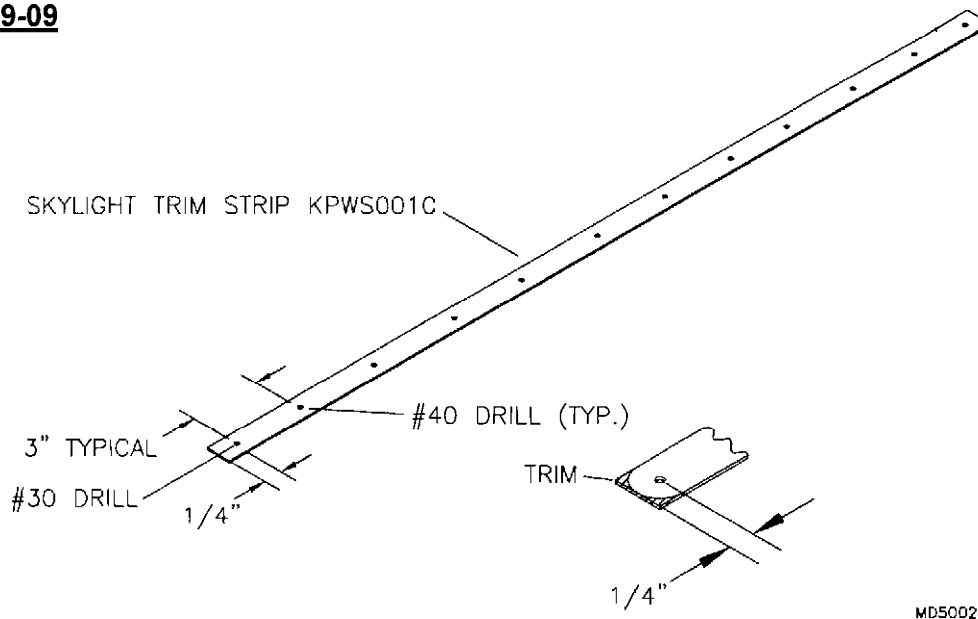


MD1443  
REV. B

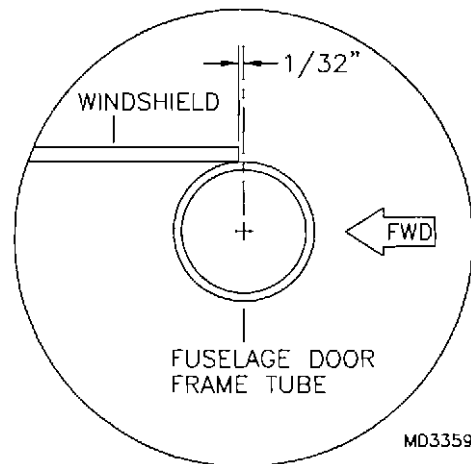
8. The windshield comes pre-cut, slightly oversized to create an overlap. Lay the windshield/skylight in position on the fuselage and ribs. Cleco the windshield to the outer pre-drilled #11 holes in the mount tab. Refer to **FIGURE 019-08**. Pull the sides down to contour around the structure and clamp or tape in place. Check for an even amount of overhang on each side and if the Lexan is down against all edges. Re-position and clamp as required. Peel back a small area of the protective plastic around the windshield tab. With the skylight centered, drill through the windshield into the remaining holes in each tab and Cleco in place.

**FIGURE 019-08**

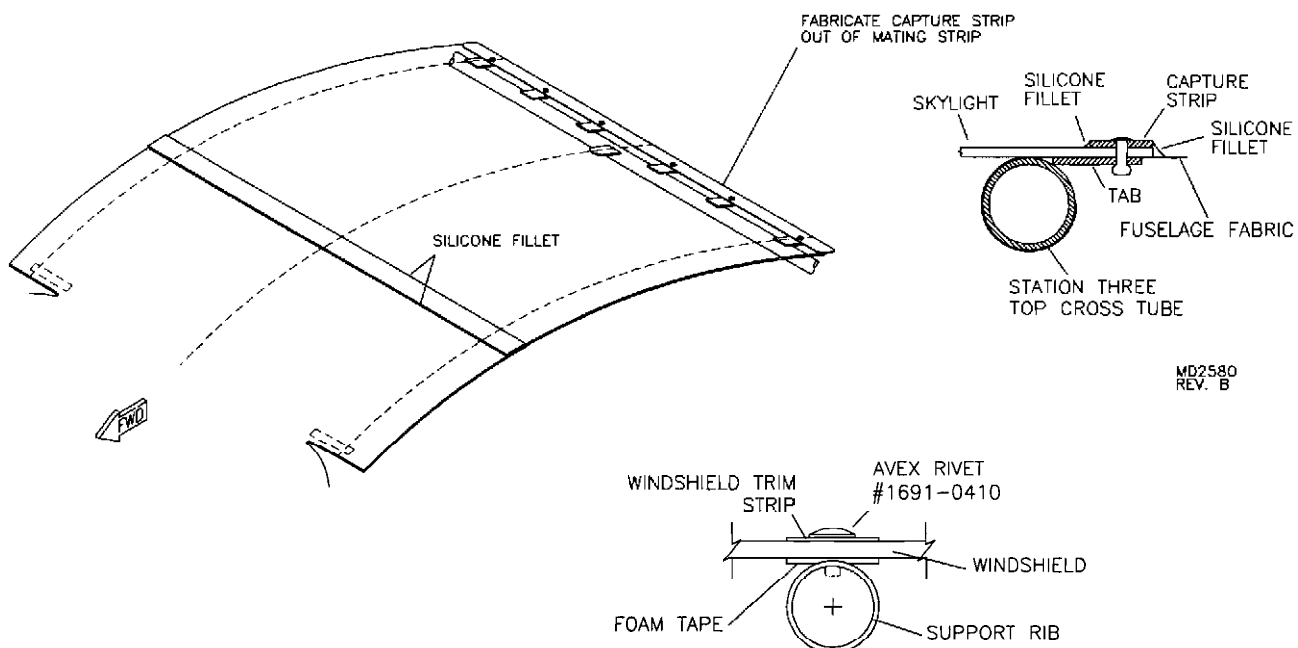
9. Layout and drill holes in the Skylight Trim Strips per **FIGURE 019-09**. Transfer drill through the windshield into the previously drilled #30 hole in each support rib. Cleco the Skylight Trim Strip to the hole in the rib. Align the strips on the centerline of each rib. Transfer drill; be sure to stay on centerline. Cleco as you drill. **HINT:** Tension the strip to the aft as you drill to prevent puckering. Trim the strip 1/4" past the hole next to the mating strips. **NOTE:** The Trim Strips will **NOT** overlap the Mating Strips. Size drill all holes to #30.

**FIGURE 019-09**

10. Position the "Z" strips inside the fuselage on the diagonals and the station two vertical cabanes. Position them with an even amount of space on each end of the "Z" strips. Press the windshield flat against the "Z" strips with a board. Using a #30 bit, transfer drill through the pre-drilled holes in the "Z" strips through the windshield. Cleco as you go.
11. Use masking tape to mark the trim line on the AFT edge of the windshield at the station two vertical side tube. Mark and trim so that the edge of the windshield is  $1/32$ " forward of centerline of the door frame tube. Refer to **FIGURE 019-011**.

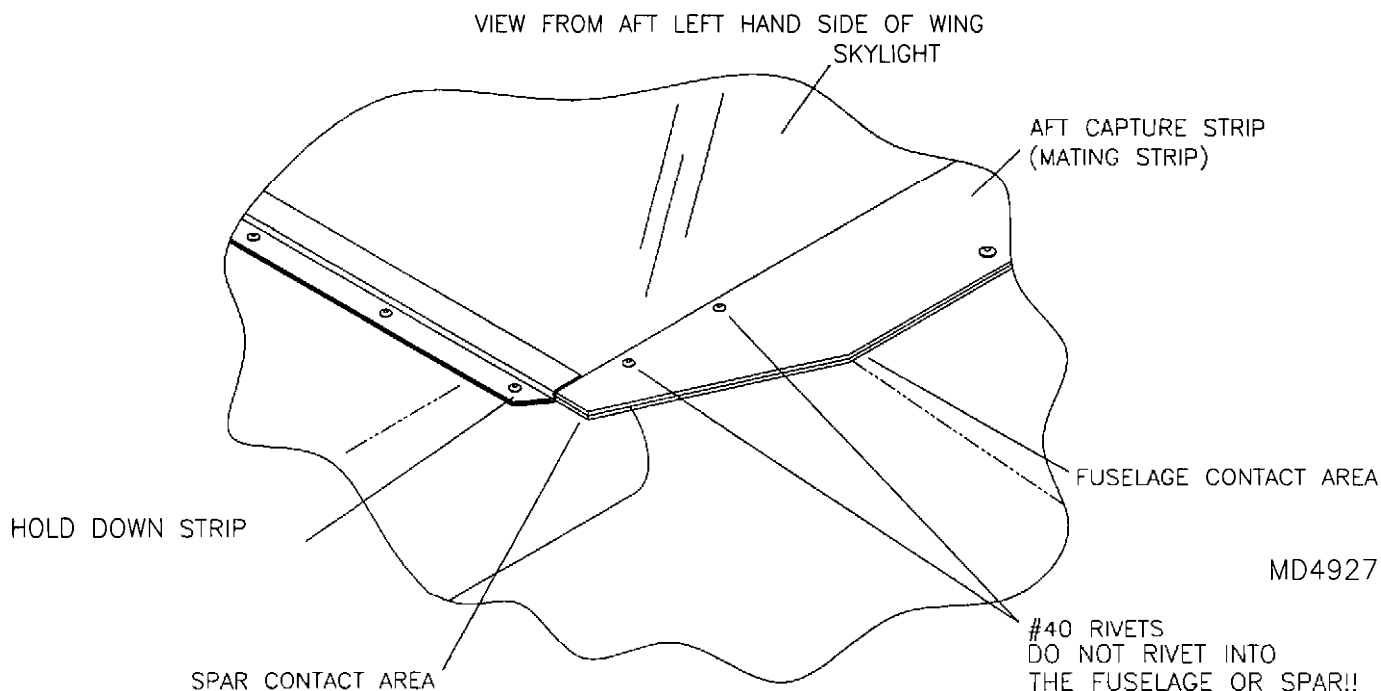
**FIGURE 019-011**

12. Mark where the top and middle ribs lay under the Lexan with a marker. Trim the protective coating out of these areas when windshield/skylight is removed.
13. Use the third skylight mating strip supplied to fabricate an aft capture strip to attach the skylight to the station 3 fuselage tabs shown in **FIGURE 019-013**. Center the mating strip on the fuselage and the S-3 tabs. Transfer drill holes to #30 and cleco in place. Work from the center of the strip out each direction.

**FIGURE 019-013**

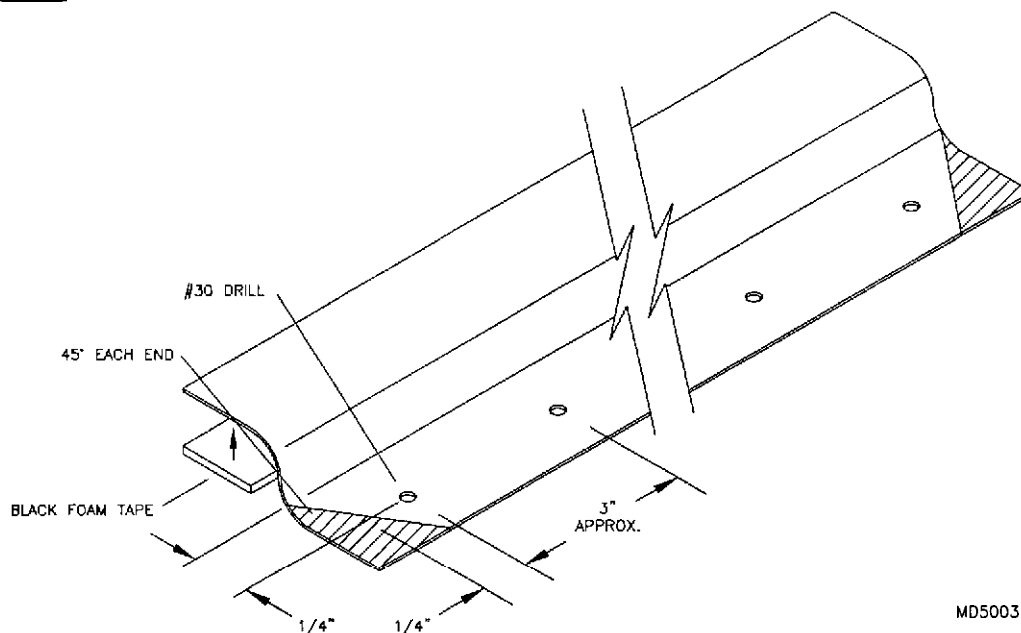
14. Trim the Skylight and Aft Capture Strip per **FIGURE 019-14**.

**FIGURE 019-014**



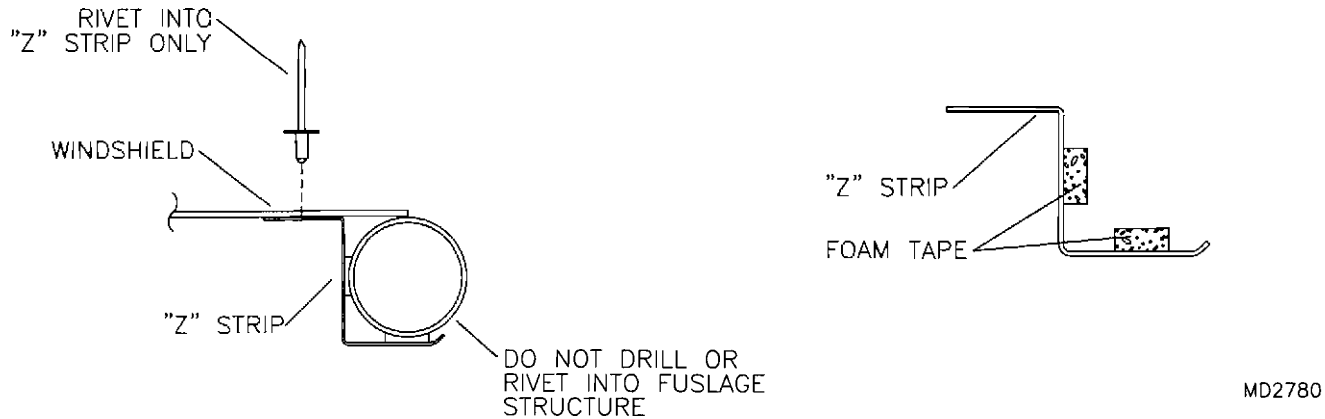
15. Position Skylight Hold Down Strip against the edge of the Skylight between the Mating Strip and Aft Capture Strip. **NOTE:** The flange with a slightly downward angle overlaps the skylight. Trim the Hold Down Strip length as needed to clear the strips. Layout and drill holes in the Skylight Hold Down Strip per **FIGURE 019-015**. Trim the ends of the Strip. Reposition the strip and transfer drill #30 into the Root Tensioning Rib. Cleco as you drill. **IMPORTANT:** The wing must be covered and skin final tensioned. **CAUTION:** Do **NOT** drill into the fuel tank or fuel lines. **Use a Drill Stop!** Remove and paint the strip if desired. Apply 1/2" black foam tape to the flange overlapping the skylight. Rivet during final assembly.

**FIGURE 019-015**



16. Remove the windshield. Drill out all holes in the Lexan to #28 and debur. The "Z" strips may be painted or left as is. Apply the foam strips to the "Z" strips. See **FIGURE 019-016**.

**FIGURE 019-016**



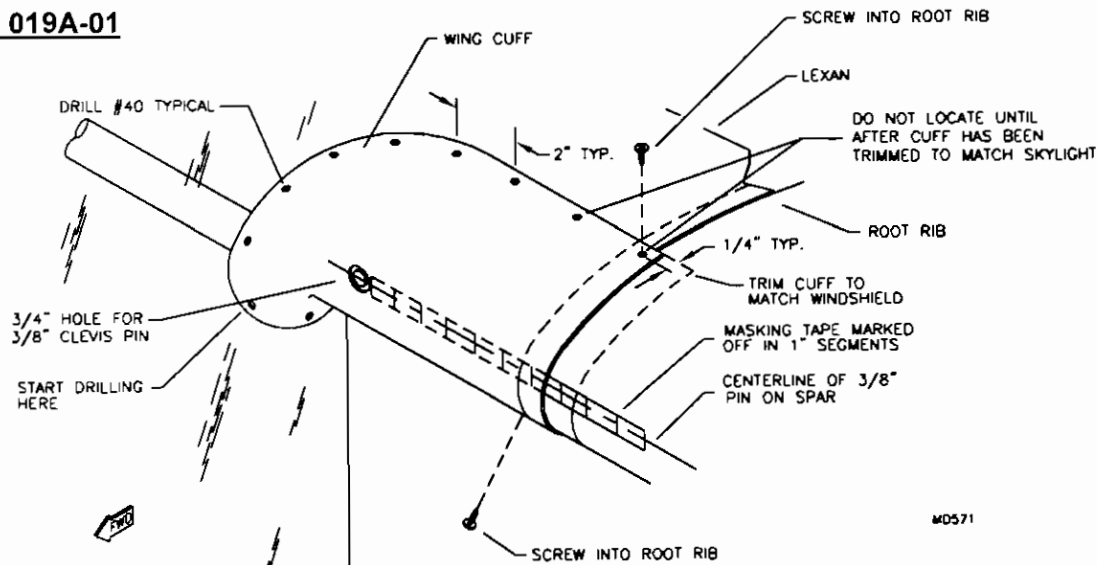
17. Apply 1/2" black foam tape to the top of each rib. Apply the 3/8" x 1/2" foam strip to the lower outer edge of the windshield/skylight. The foam will help seal against the wing. During final assembly, install the windshield/skylight, trim strips, hold down strips, "Z" strips, and rivet.

## INSTALLING THE WING CUFFS

**PLEASE NOTE:** Before the wing cuffs can be installed the wings and windshield must be on the plane.

- Before installing the cuffs place a strip of masking tape on the spar at least 8" long on the spars centerline coming off the spars 3/8" pin. Mark off the tape in 1' segments from the exact center of the pin. The tape will serve as a way of marking on the cuff where to drill for the 3/4" diameter pin access hole. See **FIGURE 019A-01**. To locate the pin under the cuff, measure into the cuff using the tape as a reference. The wing cuffs come trimmed, painted, and ready to install. Because of the springy nature of the plastic the cuffs are a bit tricky to fit up to the windshield. The trick is to start drilling and installing clecos from the **BOTTOM** to the top. A total of 9 rivets are used to retain the cuff to the windshield. Locate and mark for 9 rivets, along the edge with about a 1/4" edge distance.

**FIGURE 019A-01**



M0571

- Hold the cuff in position. By moving the cuff around a bit you will find where it fits the best. Drill through at your marks with a #30 bit and cleco as you go starting near the bottom. Push firmly on the cuff to form it against the wing as you work your way to the top. See **FIGURE 019A-01** for starting hole location.
- After drilling and clecoing the cuff in place drill a #30 hole at the top and bottom locations for #8 pan head screws. Before drilling make sure the cuff is tight against the wing by pushing it firmly into the wing. drill into the root rib on the top and into the spar on the bottom. The screws will self tap into the spar but not without an effort. Be careful not to slip off the screw and punch a hole in the wing. Remove the screws and clecos and drill the 3/4" for the wing pin in the cuff. Clean up the 3/4" hole by rolling a piece of 80 grit sanding paper into a cylinder. Sand the inside of the hole smooth, avoid scratching the paint!
- Clean the cuff and wing of any debris and apply a small bead of silicon caulking to the edge of the cuff. Cleco the cuff in place, then install the rivets and screws. Make sure you use the small brass washers to back up the rivets. Use extra care in placing the washers; make sure they are up against the Lexan before pulling the rivet. Wipe off any extra silicon with a damp paper towel. A properly installed wing cuff will contour exactly with the wing and windshield as well as provide a water tight joint against the rain.
- Install the rubber edging along the outer edges of the skylight from the cuff to the Hold Down Strip. Use a small amount of Cyanoacrylate glue (Permabond, super glue, etc.) to retain the edging in place.

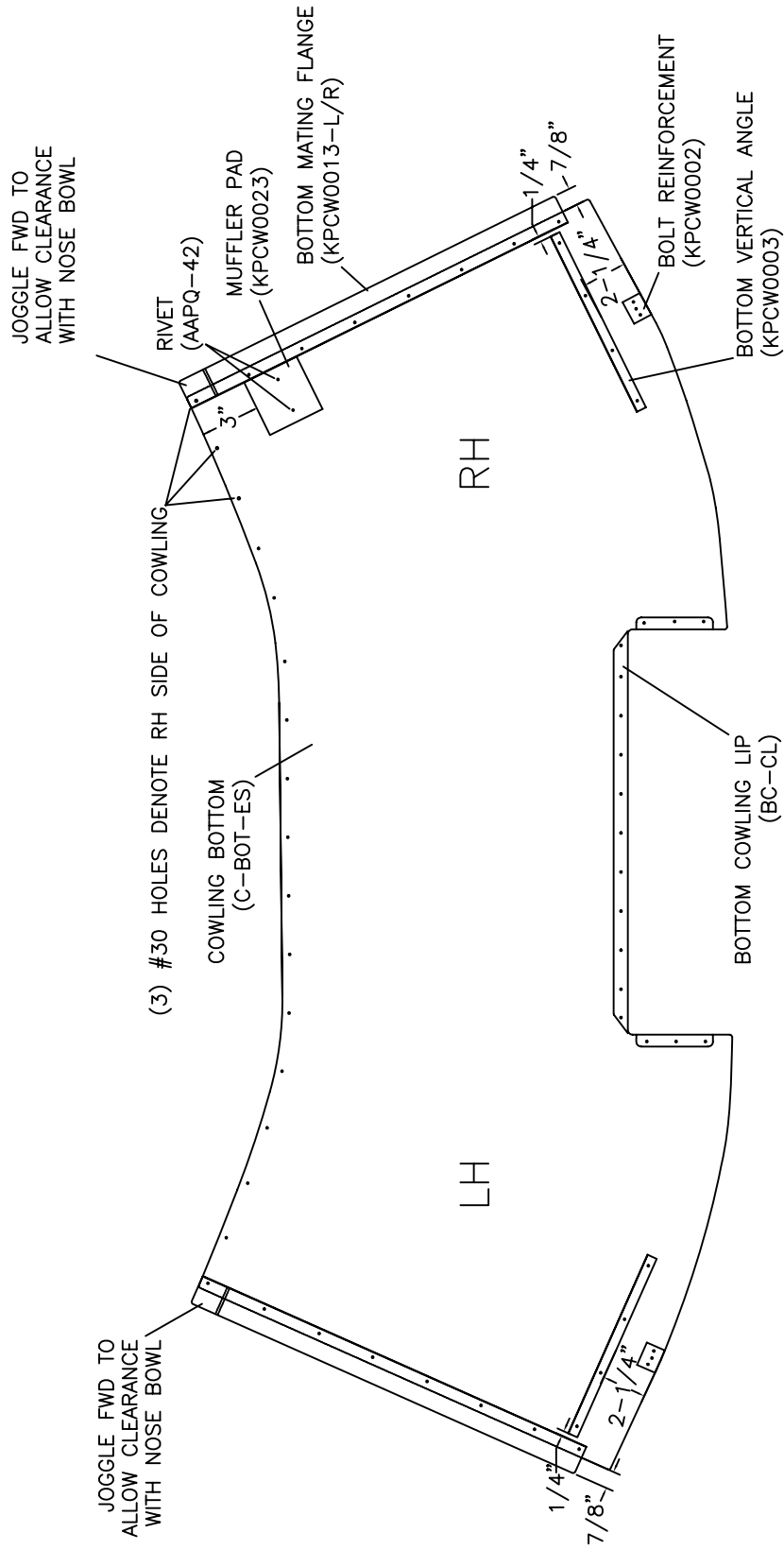
## S-6ES COYOTE II COWLING ASSEMBLY

1. Select the parts depicted on the parts page.
2. Carefully unwrap the painted cowling components (nose bowl, top and bottom halves). **CAUTION:** When working with sheet metal be careful of sharp edges. Also handle with care to avoid buckling and permanently deforming parts.
3. Install trim loc to the AFT edge of the top. Trim to length after installing. **HINT:** Lay the part on a flat table with the edge you are applying the trim loc to over hanging slightly.
4. Find the center smaller rivet hole of both the nose bowl's (bottom half) and the cowling bottom's front edge. Cleco these parts together (use copper clecos). **PLEASE NOTE:** The sheet metal fits to the outside of the nose bowl.
5. Bolt the cowling to the firewall (it is assumed the engine, firewall, windshield and nut plates are installed, it is also helpful for the fuselage to be covered). **HINT:** Super glue the 3 stack of washers together and to the inside of the cowling. It may also be necessary to slot the side and bottom bolt holes to get the stripes on the cowl to line up with the striping on the fuselage.
6. Center the top half, drill and cleco in place. **PLEASE NOTE:** The top half may need to be trimmed if it overlaps the bottom half.
7. Check the alignment by viewing from the front and side. The prop flange should be approximately centered although a slight variation either way will not matter. If it looks good remove the clecos one at a time and rivet the lower cowl and nose bowl. **PLEASE NOTE:** Be sure to use the 1/8" brass washers inside to back up the fiberglass.
8. Install 1/4 turn fasteners as per instructions and **Figure 020-1**.
9. Rotax 912 engine installations need a 1 1/2" hole for the exhaust pipes exiting the lower cowling. The mufflers should be installed on the engine at this time but not the extensions. Use a pencil and project the outline of the muffler exhaust tube to the cowling. Find the center of the pencil line circle and carefully cut out with a 1 1/2" hole saw. These holes should line up with the muffler exhaust. Now install the stainless steel extensions using the hose clamps called out in the muffler parts drawing.

### 1/4 TURN INSTRUCTIONS

1. Select parts as per parts drawing.
2. Align and drill cowling to #30 and cleco.
3. Disassemble and drill lower cowling holes out to #11.
4. Cleco a 1/4 turn receptacle into the holes and use a drill guide for the 3/32" rivets.  
**NOTE:** Do not rivet at this time
5. Drill out the fastener or middle hole to 5/16" and rivet in the receptacles.
6. Drill the holes in the top cowling out to 1/4" and install 1/4 turns as per **Figure 020-1**.





ALL RIVETS AAPQ-41 UNLESS OTHERWISE NOTED

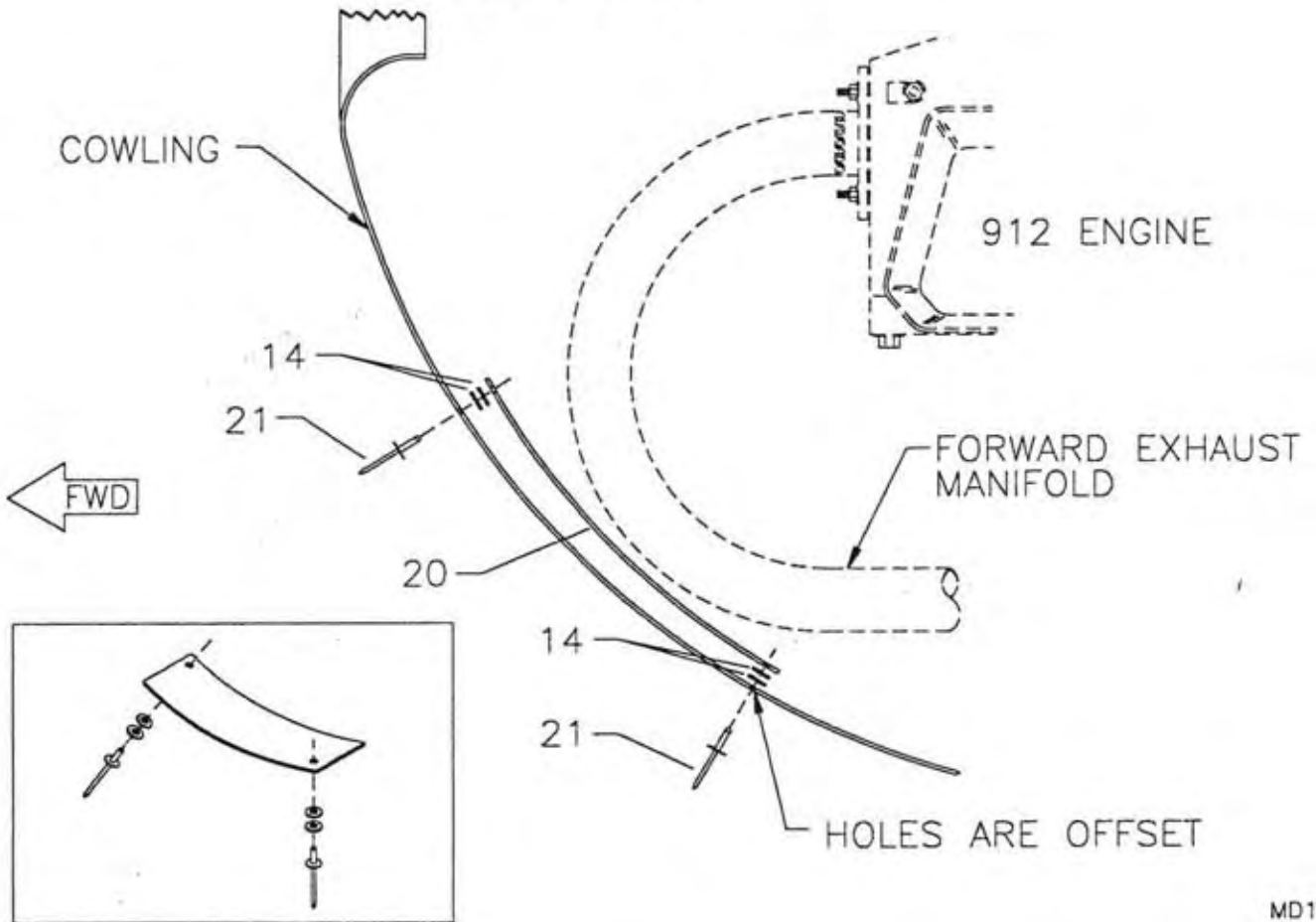
MD5546

# RRAMES S-6ES COYOTE II BOTTOM COWLING ASSEMBLY FIGURE DRAWING

**S-6ES COYOTE II 912 COWLING HEAT SHIELD ASSEMBLY**

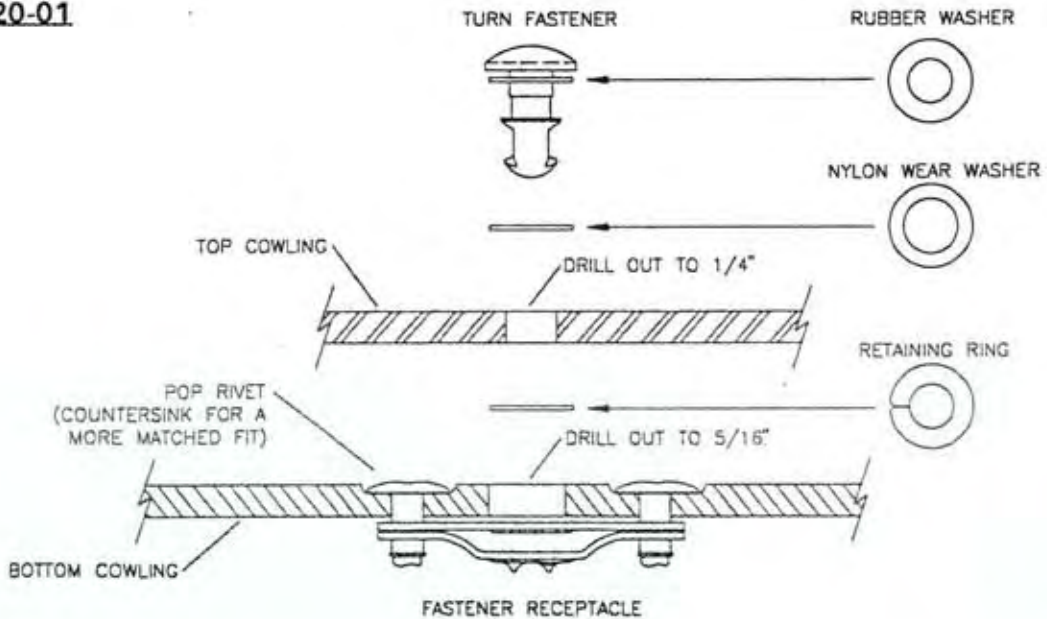
NOTE: LINE UP THE HEAT SHIELDS CENTERED ON THE CURVE OF THE EXHAUST MANIFOLD CLOSEST TO COWLING.

LOCATE 1 HEAT SHIELD PER FORWARD EXHAUST MANIFOLD.



MD1418

**FIGURE 020-01**



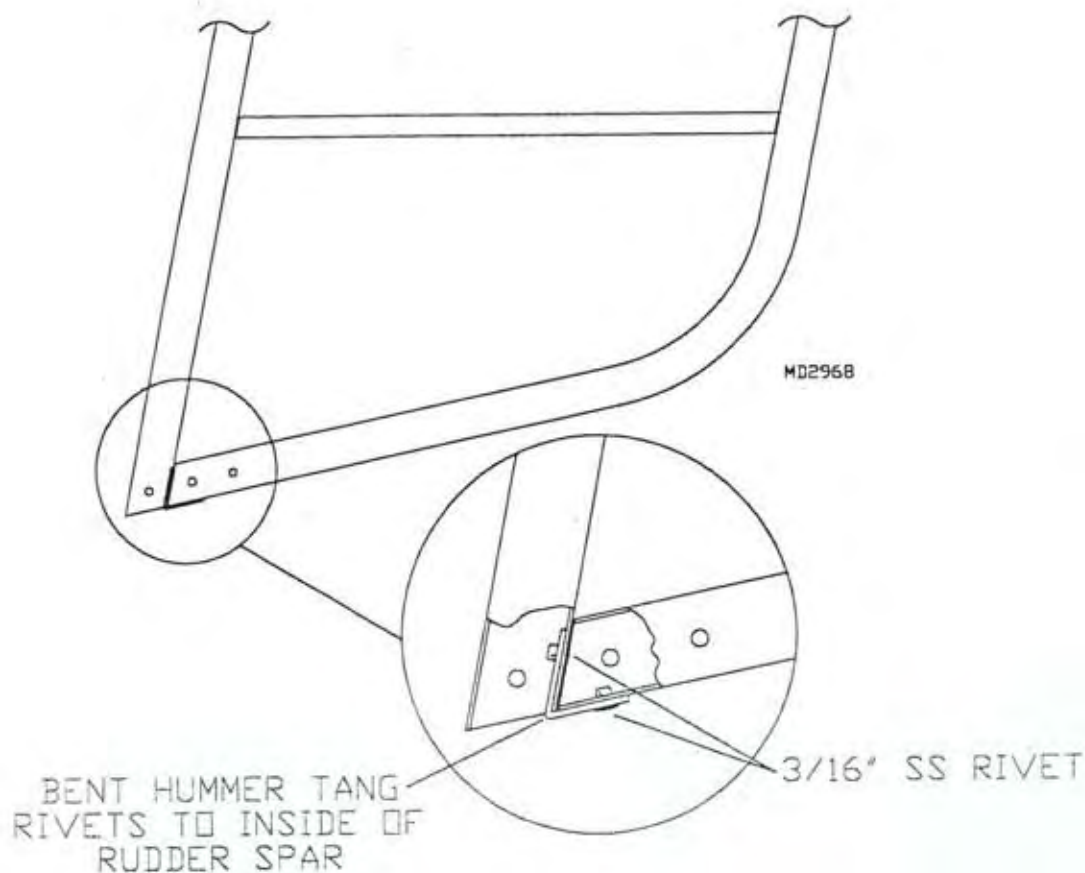
MD1418

## S-6ES COYOTE II RUDDER ASSEMBLY & INSTALLATION

The S-6 rudder is cable operated. The standard system is designed for the average person's leg length. If you feel that the seat adjustment is not enough to allow you to reach the pedals, the pedals can be tilted to the aft by adjusting the multi hole cable tangs. If a greater amount of adjustment is required, consider fabricating a custom seat cushion.

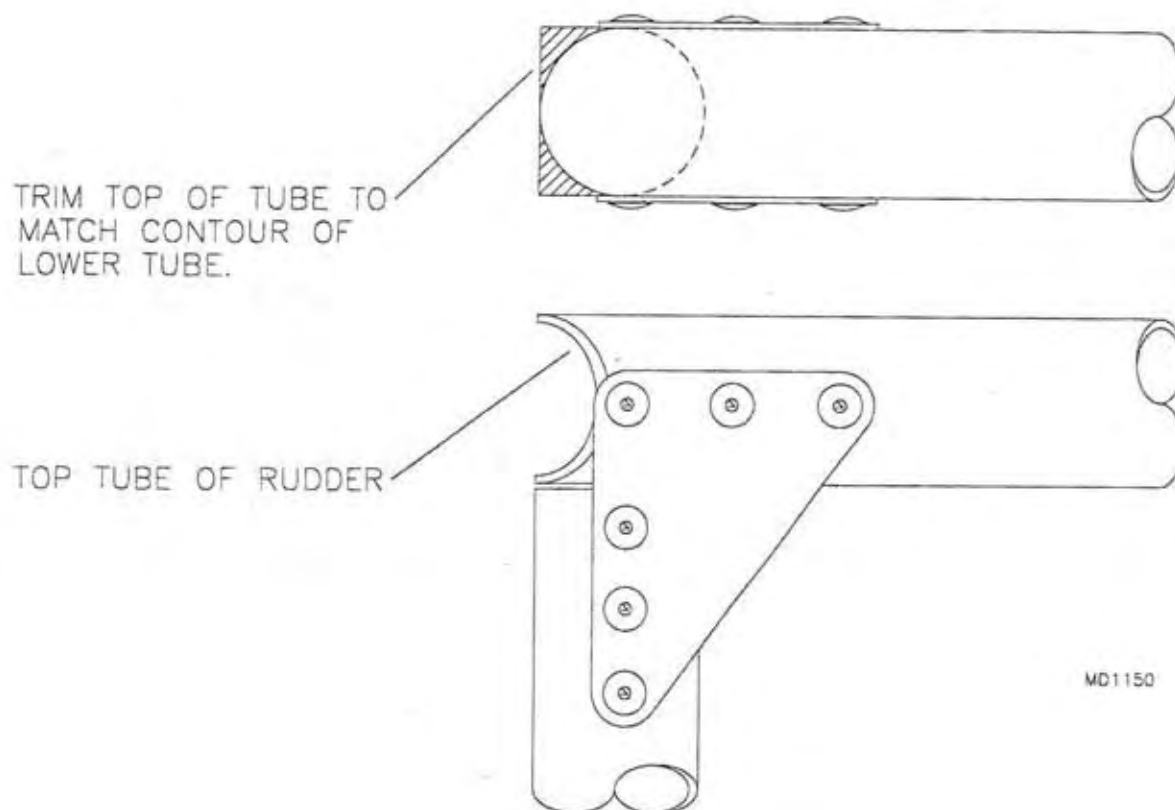
1. Note that there is a upper and lower, as well as an interior and exterior side to the leading edge spar. The upper end is distinguished by a series of three holes in the same plane drilled through the spar. The interior is distinguished by four holes that are drilled through only one wall of the spar. The two through holes are the upper and lower hinge points. Drill out the upper hinge hole to #11. Install the nut plate to the interior side of the spar. Drill out the lower hinge hole to 1/4" and install the nut plate to the interior side of the spar.
2. Install the 3/16" thick washers and 3/16" aluminum pop rivets ("buttons") to the interior side of the leading edge spar as shown in the parts drawing. The 1/2" internal brace tubes are retained by snapping them over the "buttons".
3. Drill out the pre-drilled hole in the lower interior end of the spar to #11. See **FIGURE 021-03**. Install the hummertang in the inside of the spar and rivet in place. Bend the hummertang to match the angle of the lower end of the trailing edge tube. Do **NOT** rivet the bent tang to the trailing edge at this time.

**FIGURE 021-03**



4. Install the "buttons" to the interior side of the trailing edge spar. Refer to step 2 and the parts drawing. The upper end of the trailing edge spar is distinguished by three holes in the same plane drilled completely through the spar. Position the trailing edge spar so that it is resting on top of the upper end of the leading edge spar. Refer to **FIGURE 021-04**. Cleco the gussets in place. Profile the upper end of the trailing edge spar as shown in **FIGURE 021-04**. Remove one cleco at a time, drill #30 through the gussets and re-cleco. Rivet after the Rudder Horns have been fit up.

**FIGURE 021-04**

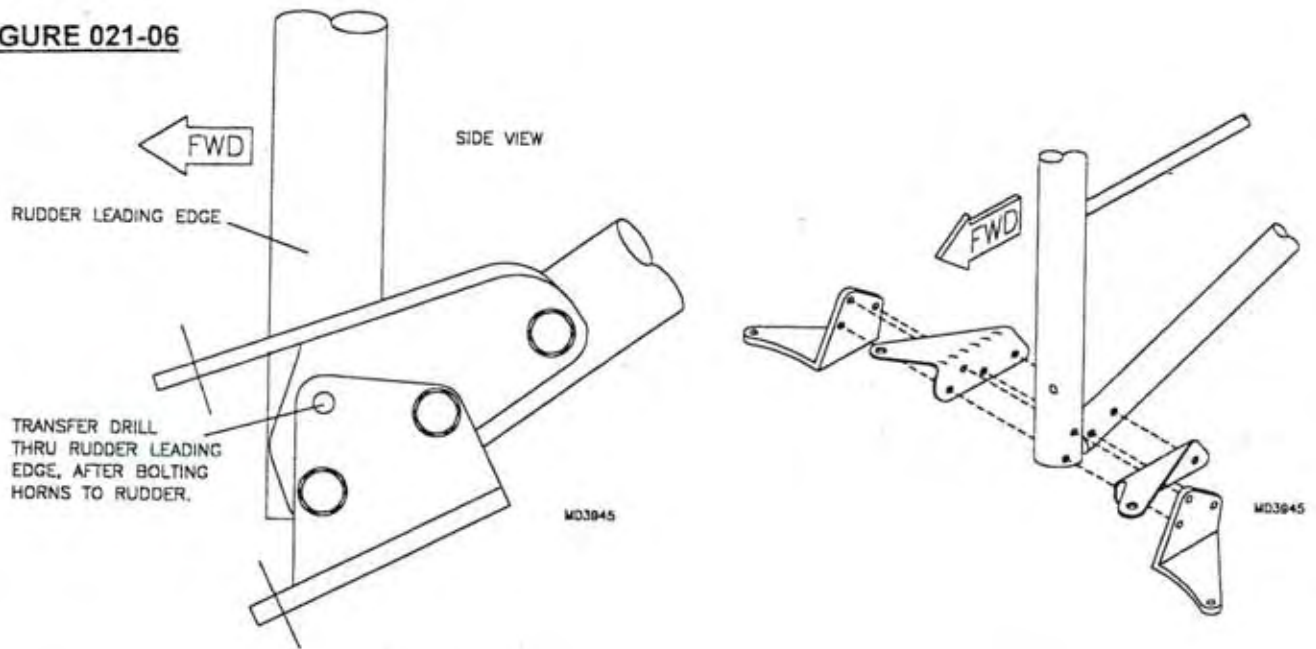


5. Drill #11 the 2 pre-drilled thru holes in the lower end of the Trailing Edge Spar. Temporarily bolt the Rudder Horns to the trailing edge. Align the forward hole in the Rudder Horns on the Rudder Spar centerline. Trim the Trailing Edge as required. **NOTE:** The trailing edge must contact the bent tang riveted to the Rudder Spar. Transfer drill #11 and temporarily bolt. Rivet the gussets to the top of the spar and trailing edge. Transfer drill #11 through the bent tang and rivet.

**NOTE:** Step 6 is for Taildragger models only.

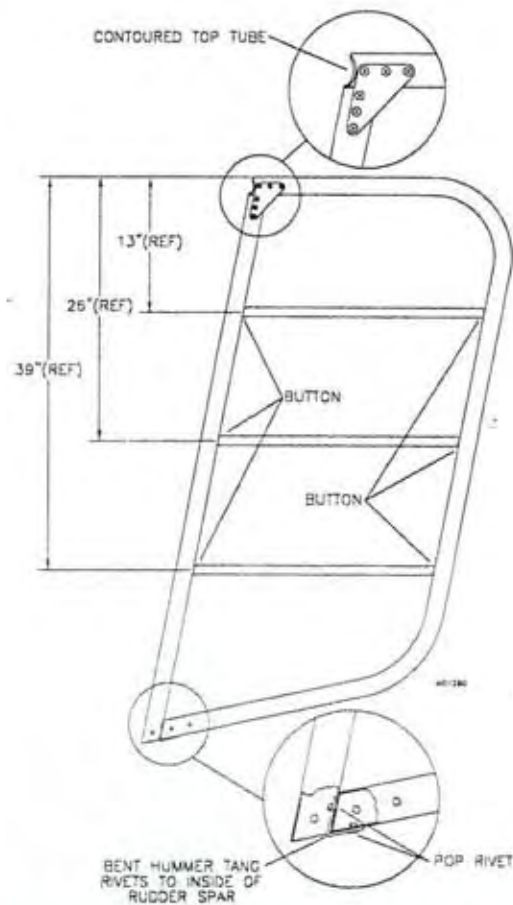
6. Bolt the Tailwheel Steerhorns on top of the Rudder Horns. See **FIGURE 021-06**. Transfer drill #11 thru the top forward hole in each steerhorn.

FIGURE 021-06



7. Measure the distance between the leading and trailing edge spars at each button location. Fabricate the internal compression tubes from the raw stock provided. Install the compression tubes by snapping them over the "buttons" on the leading and trailing edge spars. See **FIGURE 021-07**. It may be necessary to bevel the inside of the tubes to achieve the proper fit over the "buttons". **NOTE:** It is important that the compression tubes **DO NOT** bow or deform the leading and trailing edge spars.

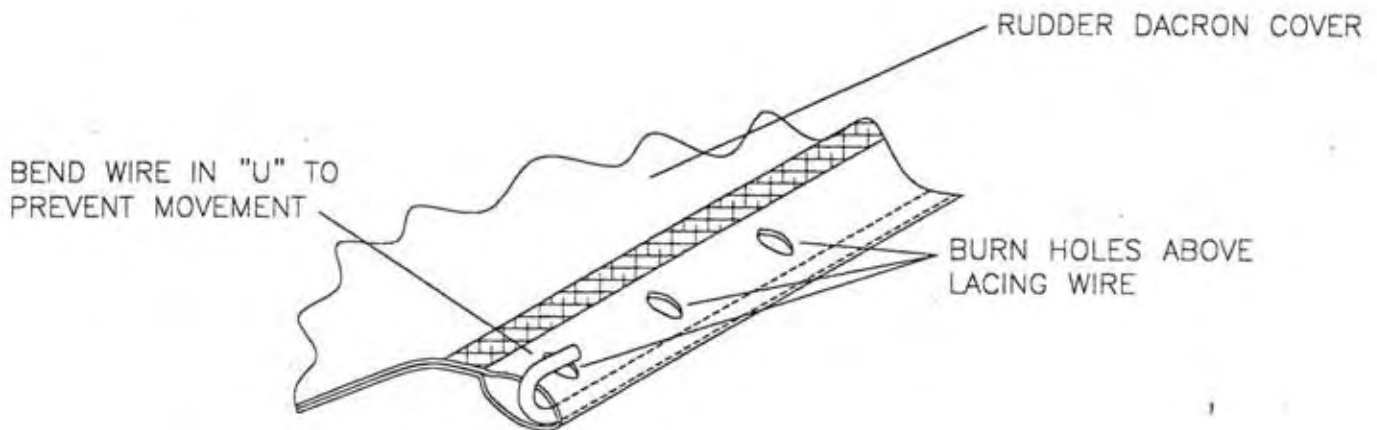
FIGURE 021-07



## S-6ES COYOTE II RUDDER COVERING

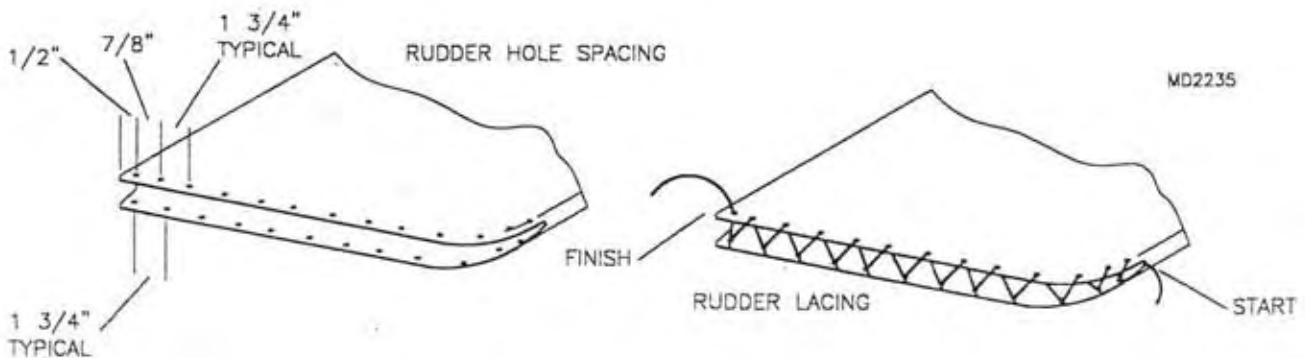
8. Remove the rudder horns and slide the skin over the rudder frame. It will be a fairly tight fit and may take some effort to pull on. Slide the 1/16" lacing wires into the pockets on the lower end of the skin. Pre-shaping the wires to follow the pocket contour will ease full insertion. Form a hook on the end of the wires to secure them into the pockets. See **FIGURE 021-08**. Layout the hole pattern as shown in **FIGURE 021-08A**. With a hot knife or soldering iron, melt through each location just above the lacing wire. Lace the tensioning cord as shown in **FIGURE 021-08B**. Start at the trailing edge and work forward pulling the cord and skin tight as you go. Several passes will be required to achieve the proper skin tension.

**FIGURE 021-08**



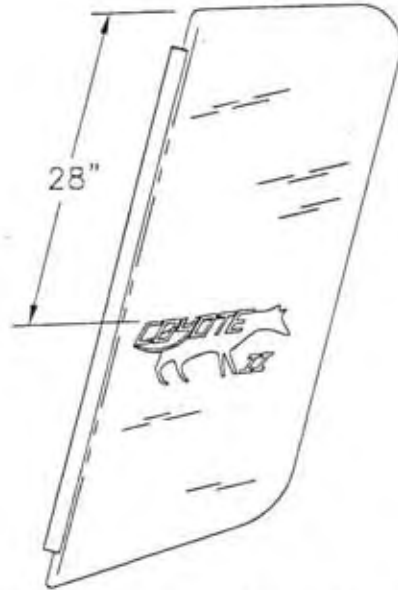
**FIGURE 021-08A**

**FIGURE 021-08B**



9. With the rudder covered and properly tensioned, place the Coyote II decal 28" down and parallel to the top of the rudder. Refer to **FIGURE 021-09**. NOTE: If clear-coating, install the decal afterward.

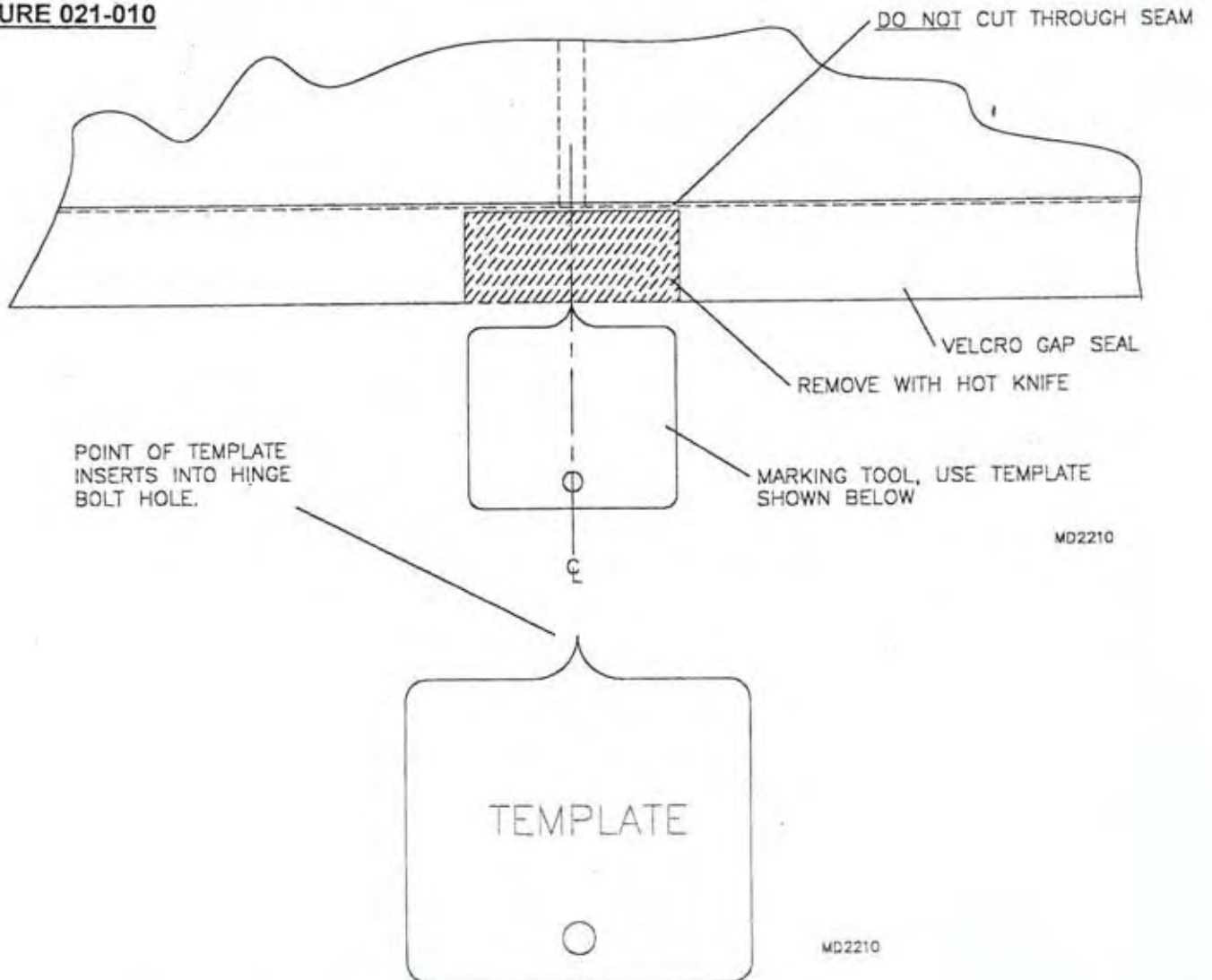
**FIGURE 021-09**



MD1464

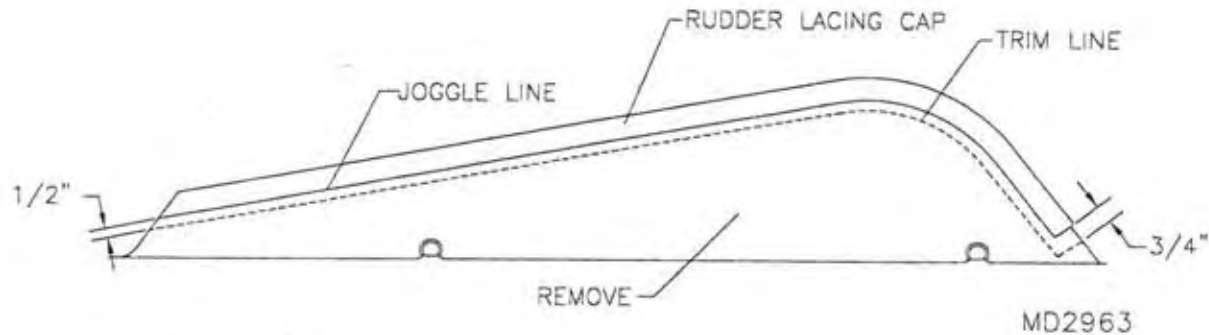
10. Use a hot-knife, (soldering iron or wood burning tool), to trim the gap seal for the upper hinge location as shown in **FIGURE 021-010**. Use the template shown as a guide. **CAUTION: Do NOT** cut into the stitching of the trailing edge. Refer to the parts drawing and install the upper hinge and lower eyebolt. Install the rudder horns.

**FIGURE 021-010**

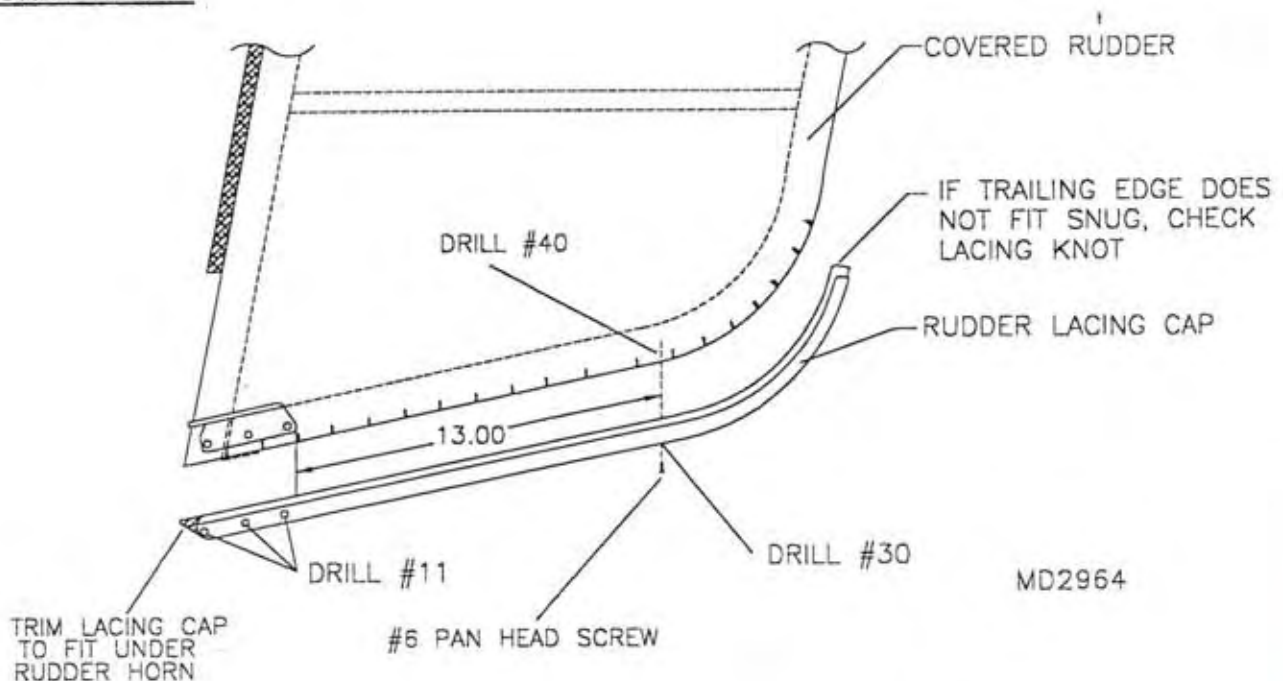


11. Trim the rudder lacing cap as shown in **FIGURE 021-011**. Install the lacing cap onto the rudder and trim to fit under the rudder horns. Check for a snug, uniform fit against the rudder skin. It may be necessary to re-tie the lacing knot in order to obtain the proper fit. Locate and drill the mounting holes as shown in **FIGURE 021-011A**. Cleco in place. Drill #11 through the lacing cap to match the rudder horn holes. Attach the lacing cap using the proper hardware. **NOTE:** The lacing cap may be painted to match the rest of the aircraft.

**FIGURE 021-011**



**FIGURE 021-011A**



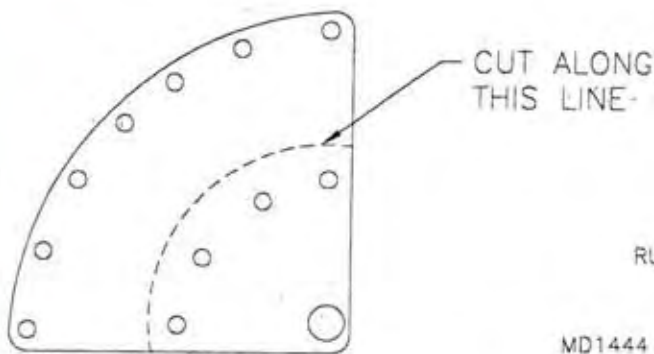
12. Attach the rudder to the aircraft with the proper hardware. Refer to the parts drawing. Place a small drop of light oil on each hinge and check for free movement. It may be necessary to file a half moon notch in the rudder horns where they contact the tail channel in order to obtain full rudder travel. Check for Rudder/Elevator clearance. A 1/2" minimum clearance must be maintained through the full range of elevator travel at full rudder deflection.



## RUDDER CABLE INSTALLATION

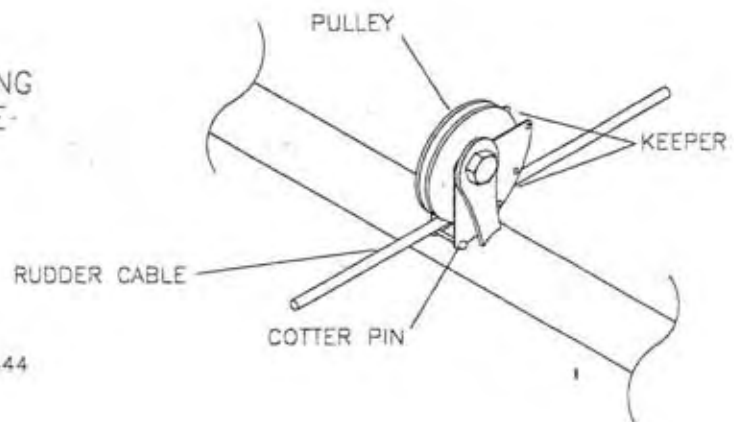
13. Note the orientation of the rudder cables. Install the washers, straight multi-hole tang (on the rudder cable), aluminum bushing and rudder bungee return to the rudder pedals as shown in the parts drawing. Note the sequencing of all parts. Install the castle nut and cotter pin. Do not over tighten; the rudder cable tang must swivel freely. Route the cables through both sets of pulley tangs, located at station 2A and station 3. Trim the cable keepers as shown in **FIGURE 021-013**. Install the cable keepers, pulleys and cotter pins. Position the cable keepers as shown in **FIGURE 021-013A**. Note that the cotter pins **DO NOT** secure the keepers. The tension in the pulley mounting bolt secures the keepers. The cotter pins are used to retain the cable in the pulley.

**FIGURE 021-13**



MD1444

**FIGURE 021-13A**



MD2969

14. Fabricate the aluminum bushings as shown on the parts page and bolt the cable guides to the Station 6 bottom crossing tube. Note the orientation of the guides. Route the rudder cables through each guide and on to the rudder horns. Bolt the rudder cables to the horns as shown in the parts drawing. Do not over tighten this bolt. The bolt must be tight enough to eliminate any play and yet still allow the tang to swivel. Disconnect the cables from the rudder, coil and tie out of the way prior to covering.

15. Locate and drill a 1/4" hole in the firewall directly forward of the rudder bungee return. Thread the bungee through the firewall, slide the large washer over the bungee, tension the bungee and tie a knot to retain. The bungee should be tensioned to its maximum amount while still allowing full rudder pedal travel.

16. Refer to the rudder pedal and nose gear installation sections for the steer link rod installation.

## S-6ES COYOTE II – STANDARD WING ASSEMBLY

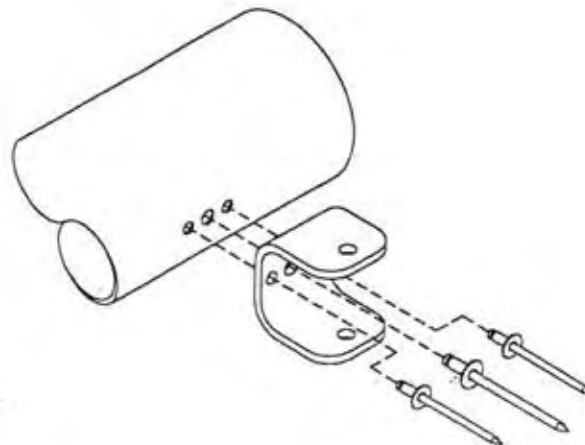
**PLEASE NOTE:** If you are building a 116 wing, jump ahead to the 116 wing assembly in this section.

### LEADING EDGE SPAR ASSEMBLY

**NOTE:** Assemble both spars the same but **make a LH and RH.** This will be true for the aft spars as well.

1. Select the necessary parts as shown in the parts drawing.
2. The leading edge spar comes with all but one of the holes pilot drilled. The final hole sizes are called out during assembly. **PLEASE NOTE:** The front side of the spar has four (4) holes for the tip bow rivets. The 5th hole goes through the spar and serves to hold the pitot tube in the left wing.
3. Bolt the long wing channel to the first hole 55" outboard of the root. Position the channel so the unbolted end points to the root. Line up the channel parallel with the spar and then drill and rivet with a 3/16" stainless steel pop rivet through the remaining hole. (Only drill through one side of the spar).
4. Drill out the three holes in a row to 3/8". For best accuracy, lay the strut attach plate against the spar holes and use it as a template. In fact, it is best to drill through with a 1/4" drill, bolt the plate to the spar, then drill the other two holes out to 1/4". Remove strut plate and drill existing 1/4" holes out to 3/8". **NOTE:** Drill from each side, (not from one side) through to the other. Debur and install the 3/8" x 3" bushings, 1/4" bolts, strut attach plate, and wing channel as shown in the parts catalog.
5. Rivet an S2-SAB to the spar using a single 3/16" stainless steel pop rivet. Drill a #30 hole on each side of the 3/16" rivet. Rivet with 1/8" stainless steel pop rivets. **CAUTION:** These rivets must be stainless steel pop rivets. DO NOT use aluminum pop rivets. See **Figure 022-05**. **NOTE:** The outboard compression tube (W-IO) will bolt to this bracket and another S2-SAB rivets to the aft spar's forward side in the same location after the tip extension is installed.

**FIGURE 022-05**



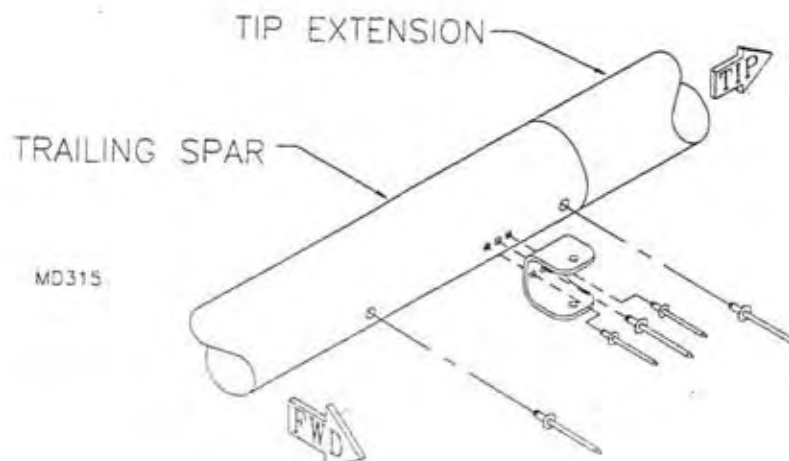
MD997

## TRAILING EDGE SPAR ASSEMBLY

**NOTE:** The front side of the spar has three (3) holes near the outboard end for riveting the spar tip.

6. Bolt a long wing channel to the #11 hole drilled through the spar 6 3/4" from the root end. The unbolted end should point inboard. Line up the channel parallel and drill and rivet with one (1) 3/16" stainless steel pop rivet.
7. Collect the parts shown in the universal hinge drawing. Make and insert the bushings into the bushing fittings. Press the bushings into the ends of the bushings on the spar fitting. If the bushings do not press in, glue them in using a dab of J & B Weld. Test fit the fitting into the end of the spar. It most likely will need to be ground to contour the spar's inside diameter. Assemble the hinge into the trailing edge spar's inboard end. Use the first and second bolts at the spar's root to attach the fitting. The bolt that attaches the hinge cube is used to attach one "L" bracket. The "L" bracket is used for the root rib tensioning system. Only finger tighten the bolt at this time. Rivet a 3/16" nut plate to the front side of the rear spar for the first inboard bolt. This bolt is used as a flap hinge point. The nut plate is required due to wing covering limiting access for a nut.
8. Bolt a long wing channel to the trailing edge spar at the hole 53" outboard of the root on the same side as the inboard channel. Position the unbolted end to the TIP side. Line up the channel parallel and drill and rivet with 3/16" stainless steel pop rivets.
9. Drill the three holes (strut plate attachment) in a row following the same procedure as in step 4.
10. From the parts drawing determine the location of the remaining hinge bolts. Rivet on the forward side of the spar 3/16" nut plates. Position these nut plates parallel with the spar. Also rivet two (2) 3/16" nut plates to each trailing edge spar tip on the side with the 1 3/8" hole.
11. Slip the trailing edge spar tip into the spar. Be sure that the hinge holes in the tip extension are radially in line with the holes in the trailing edge spar (Make sure that the large hole in the end of the tip extension is pointing forward). Drill the holes in the tip extension using the holes in the T.E. spar as guides. It is wise to cleco each hole as you go. Rivet the tip extension to the spar with three 3/16" stainless steel pop rivets. The middle hole is used to attach the S2-SAB at this time using the stainless steel pop rivet shown in the parts manual. Drill a #30 hole on each side of the 3/16" rivet and install the 1/8" stainless steel pop rivets shown in the parts manual. See **Figure 022-011**. **CAUTION:** These rivets must be stainless steel pop rivets. **DO NOT** use aluminum pop rivets.

**FIGURE 022-011**

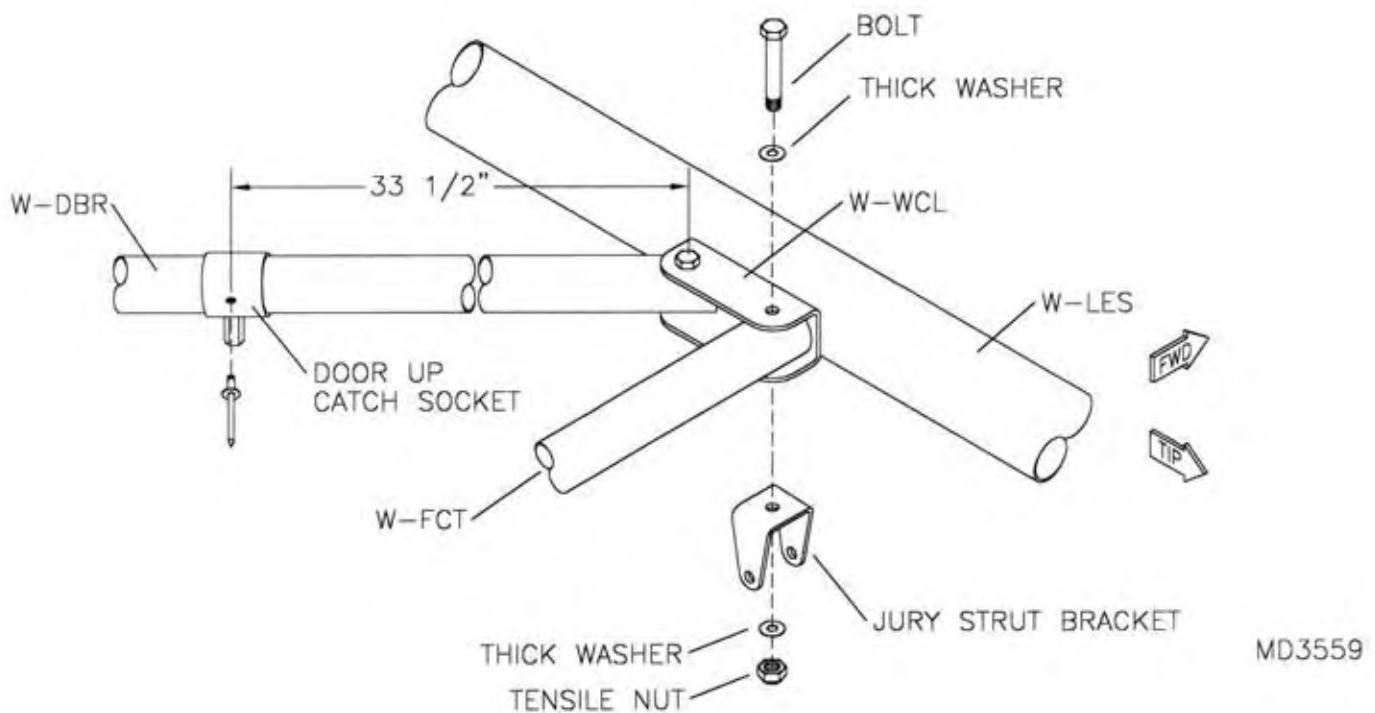


## INTERNAL BRACING TUBE ASSEMBLY

Refer to the wing internal bracing tubes and control stick sections for parts selection.

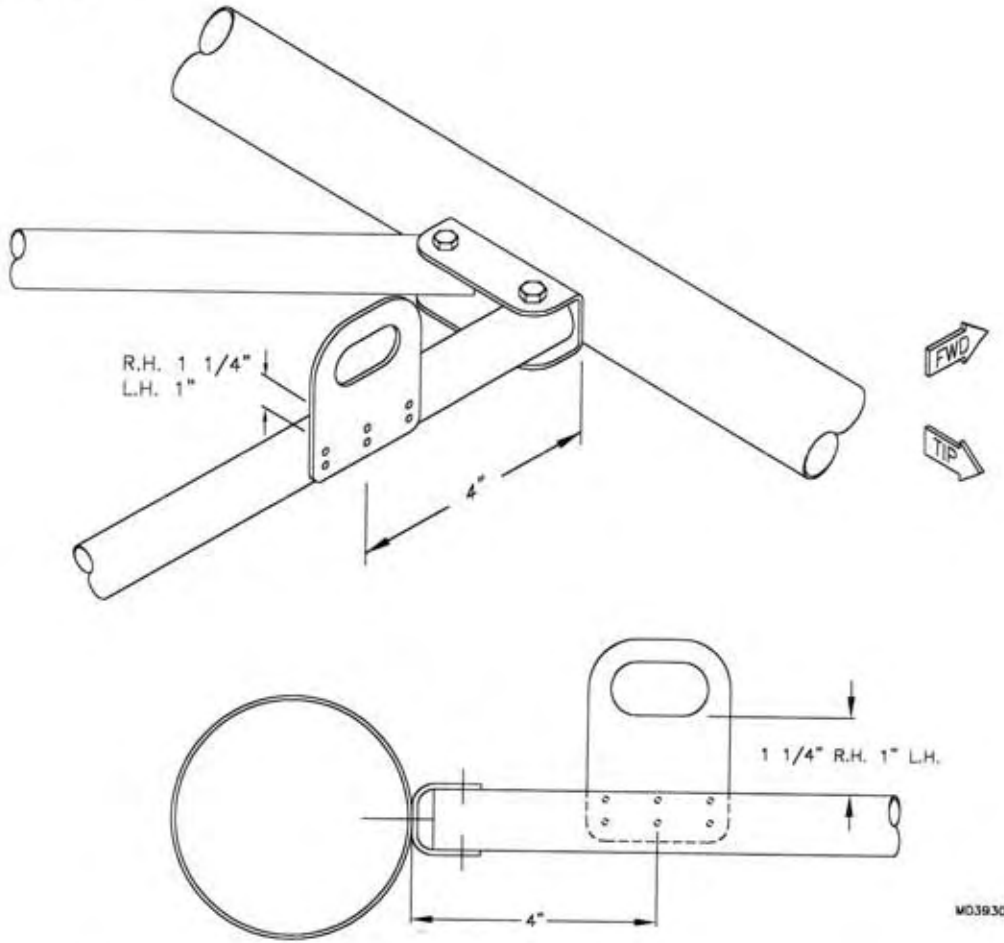
12. Refer to the wing internal bracing tubes and select the parts for assembly.
13. Slide the door upcatch onto the root drag brace and install the drag braces. Slide the compression tube doubler onto the middle compression tube and install all compression tubes. Note that the flap compression tube is positioned with the teleflex retainer mount and aft jury strut mount holes toward the trailing edge and that the forward jury strut bracket attaches to the leading edge mount bolt. **IMPORTANT:** Double check the position of the jury strut bracket before covering the wing! **IMPORTANT:** Refer to the parts drawing. Position and rivet the door upcatch in place, as shown in **FIGURE 022-013**.

**FIGURE 022-013**

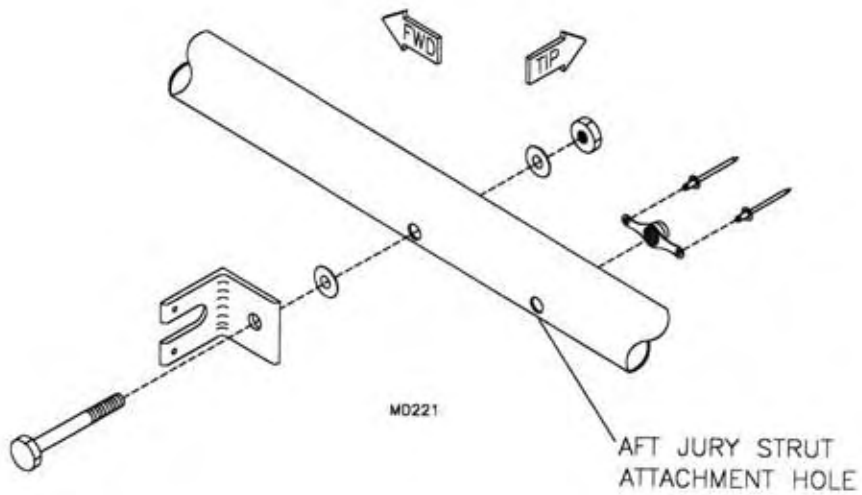


14. Locate aileron push pull tube guide on second outboard compression tube (W-FCT), as per **Figure 022-014**. Install the flap teleflex retainer bracket to the W-FCT tube as shown in the parts drawing. Note the position and orientation of the bracket. **IMPORTANT:** Be sure to install the flap teleflex retainer on the W-FCT tube to the inside. See **Figure 022-014A**. Install the 3/16" nut plate, for the aft jury strut, to the outboard side.

**FIGURE 022-014**

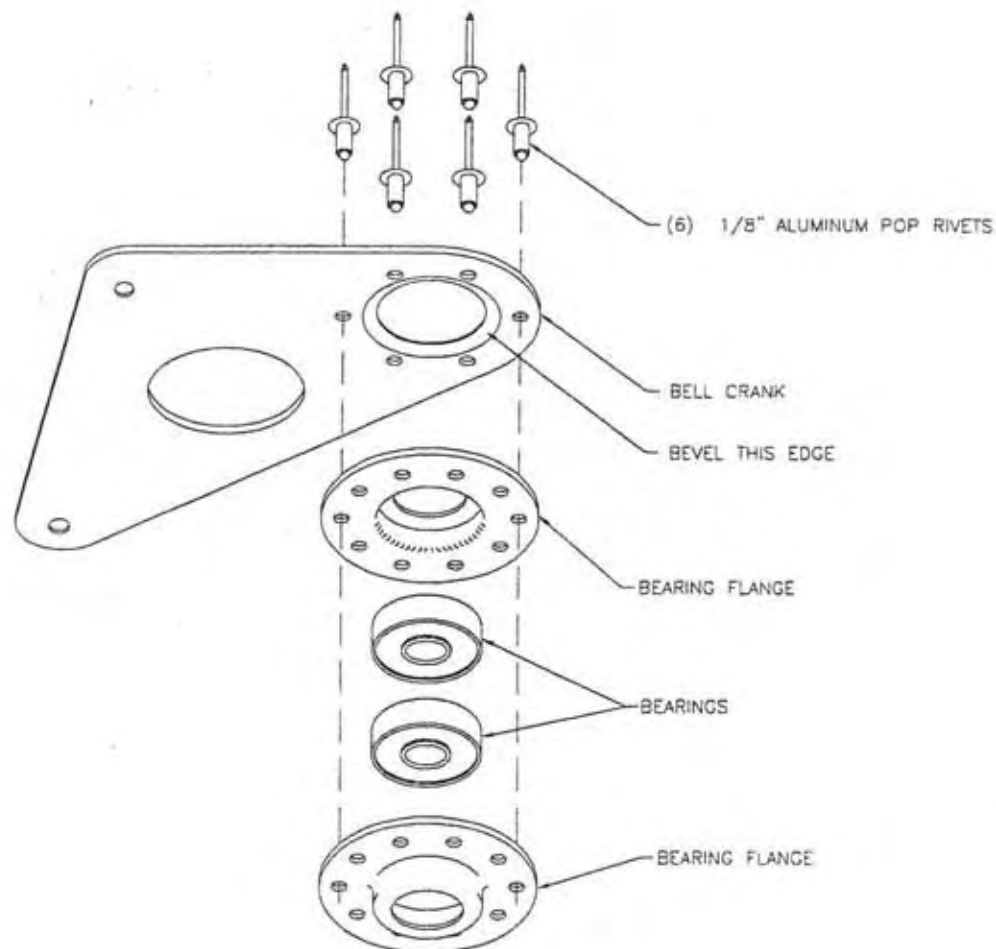


**FIGURE 022-014A**



15. Drill out the  $\frac{3}{4}$ " hole on the bellcrank to  $\frac{7}{8}$ ". It will be necessary to bevel the hole's inside edge to allow the bearing to fit flat against the bellcrank. Place the flange bearing in the bellcrank hole. Drill and rivet **every other hole** in the flange bearing for a **total of six holes** (see control stick). Pay close attention to which side of the bellcrank the bearing rivets to and make one for the left and one for the right. See **Figure 022-015**. Install the aileron bellcranks as shown in **Figure 022-015A**. The bellcrank gusset bolts to the channel bracket's two bolts, the other holes are located over the compression tube. Starting from the bottom, drill out to  $\frac{1}{4}$ " through the compression tube, doubler and gusset. From this  $\frac{1}{4}$ " hole, drill a #30 hole  $1 \frac{13}{16}$ " FWD towards the channel bracket and rivet the gusset to the tube and doubler using a  $\frac{1}{8}$ " stainless steel pop rivet. See **Figure 022-015A**. **IMPORTANT:** Install the bellcrank gusset with the small flange pointing **DOWN**. Install the aileron bellcrank with the bearing on the **UNDERSIDE** of the bellcrank. The longer arm of the bellcrank should be to the wing tip side of the compression tube for attachment to the short aileron push pull tube.

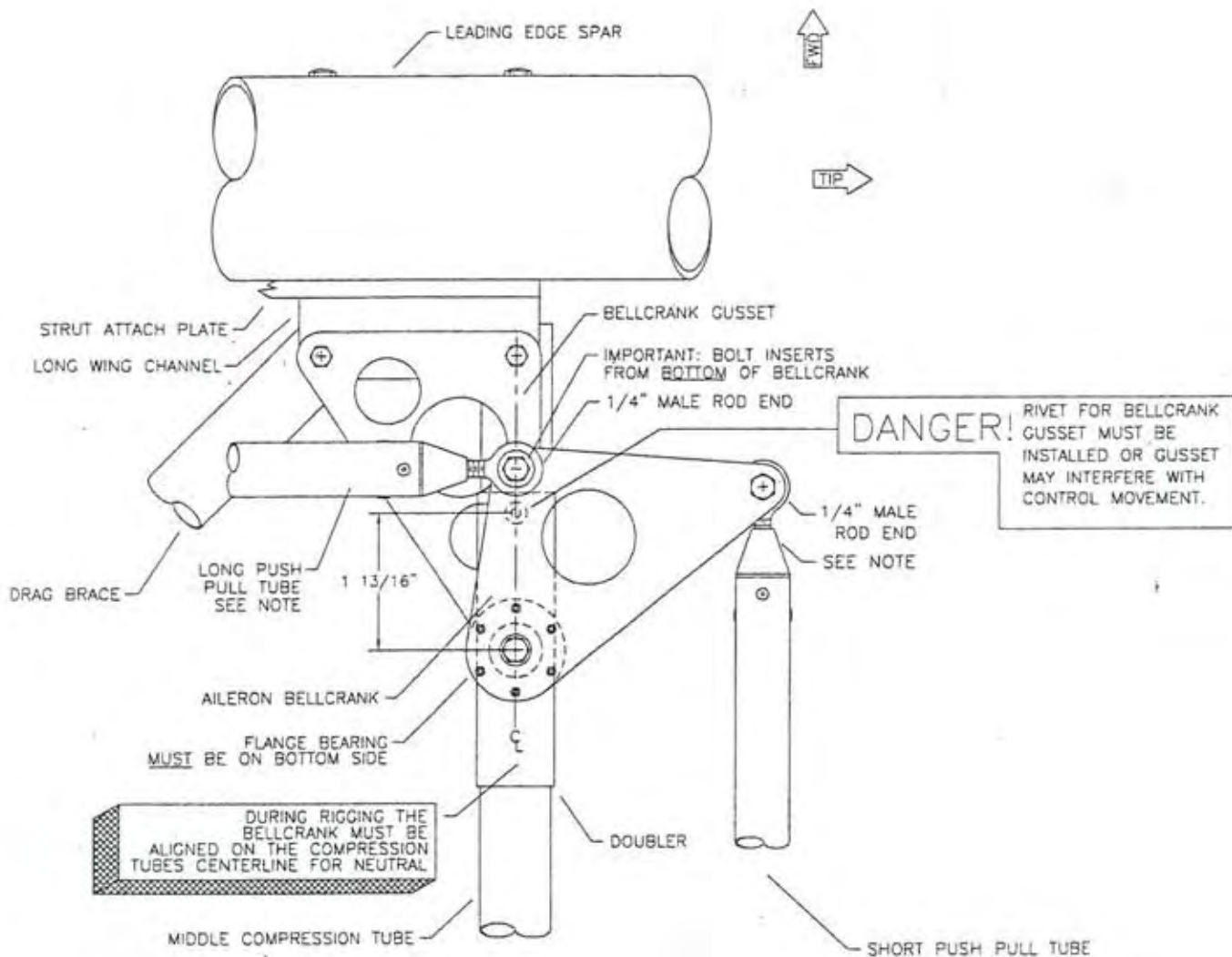
**FIGURE 022-015**



MD105

ATTACH FLANGE BEARING WITH  
(6) 1/8" ALUMINUM POP RIVETS.  
MAKE A LEFT AND RIGHT BELLCRANK.

FIGURE 022-015A



**IMPORTANT:** SMALL FLANGE ON GUSSET MUST POINT DOWN

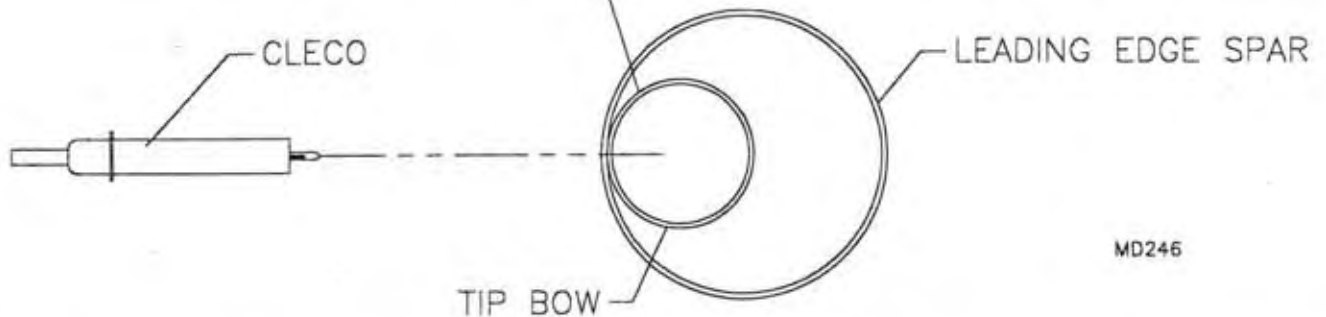
**NOTE:** STOP NUT OR BOTTOM OUT PUSH PULL TUBE ON BELLCRANK DURING FINAL ASSEMBLY. THE ROD END IS LEFT ATTACHED TO THE BELLCRANK AFTER COVERING THE WING THE AILERON PUSH PULL TUBE IS INSERTED THROUGH THE EXIT HOLE IN THE WING AND SCREWED INTO THE ROD END.

MD243

## TIP BOW INSTALLATION

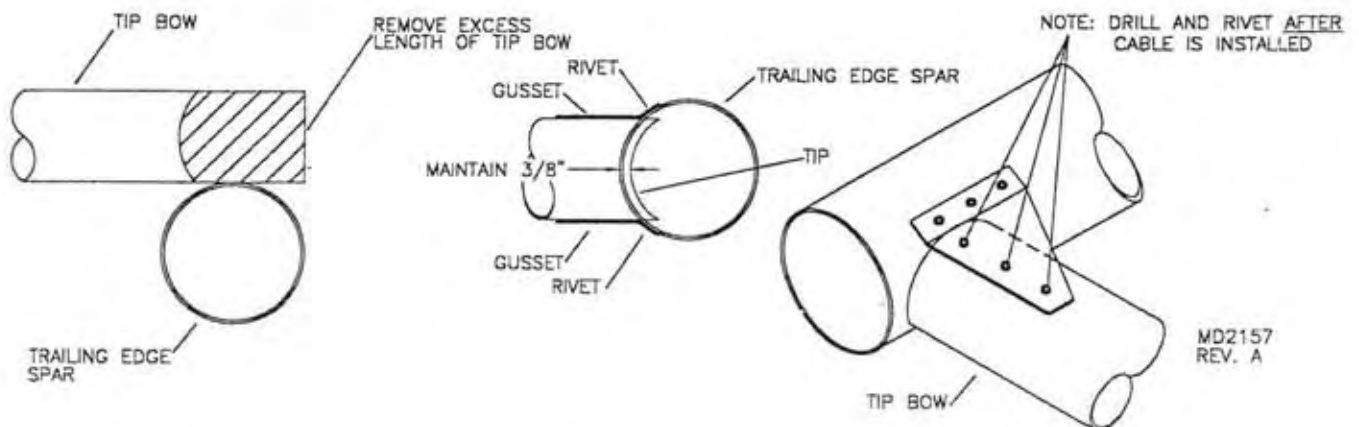
16. Insert the tip bow's drilled end into the leading edge spar so the tip bow's hole line up with the fourth inboard hole and then cleco in place. **IMPORTANT:** The tip bow must be flat against the spar on the inside. See **Figure 022-016**. Line up the bow parallel with the spar and drill through the remaining three (3) holes and cleco.

**FIGURE 022-016** TIP BOW MUST FIT FLAT AGAINST INSIDE WALL OF LEADING EDGE SPAR.

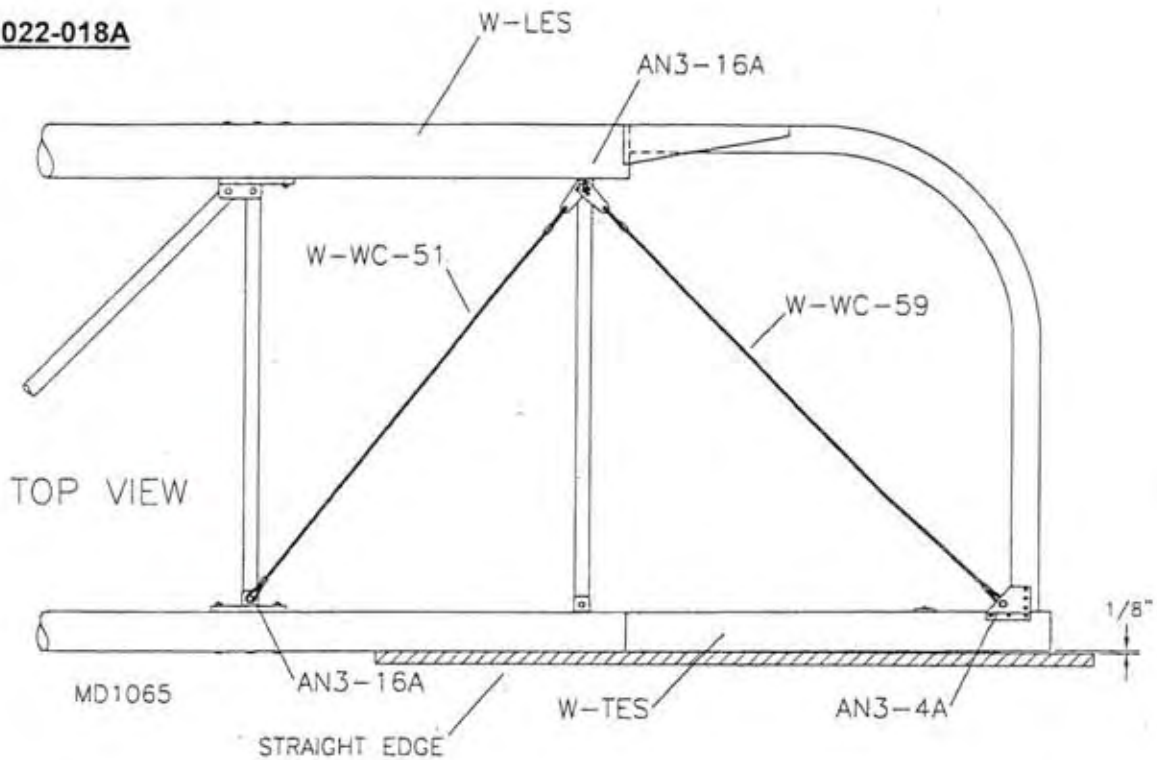


17. Cut and fit the tip bow's outer trailing end into the trailing edge spar tip. The tip should enter the trailing edge spar at approximately 90 degrees. About 1 1/2" of it will have to be trimmed off the fitted end of the tip.
18. Align, transfer drill #30 and cleco the top and bottom tip gussets to the spar tip. See **Figure 022-018**. Tension the tip to 1/8" "bow". Refer to **Figure 022-018A**. Use a straight edge to measure. Trim tip bow as shown in **Figure 022-018**. Use the 2" tube with the 1 3/8" half hole to mark the tip end. Transfer drill #30 through the tip gussets into the tip bow. Cleco as you drill. Rivet with 1/8" stainless steel pop rivets.

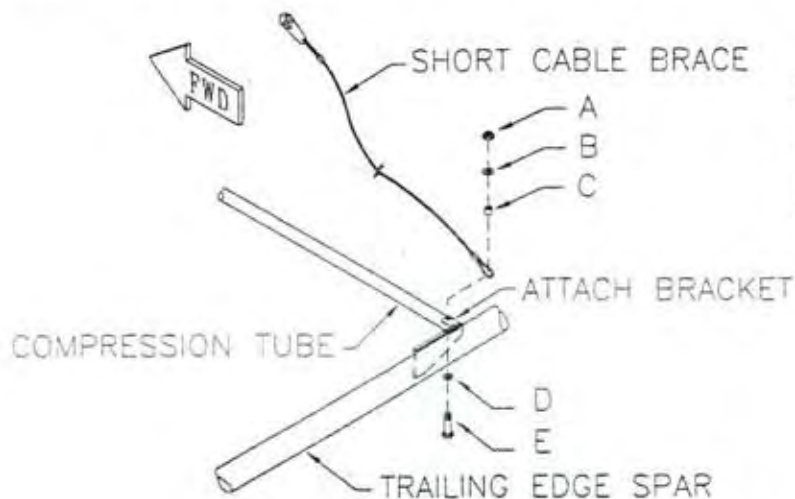
**FIGURE 022-018**





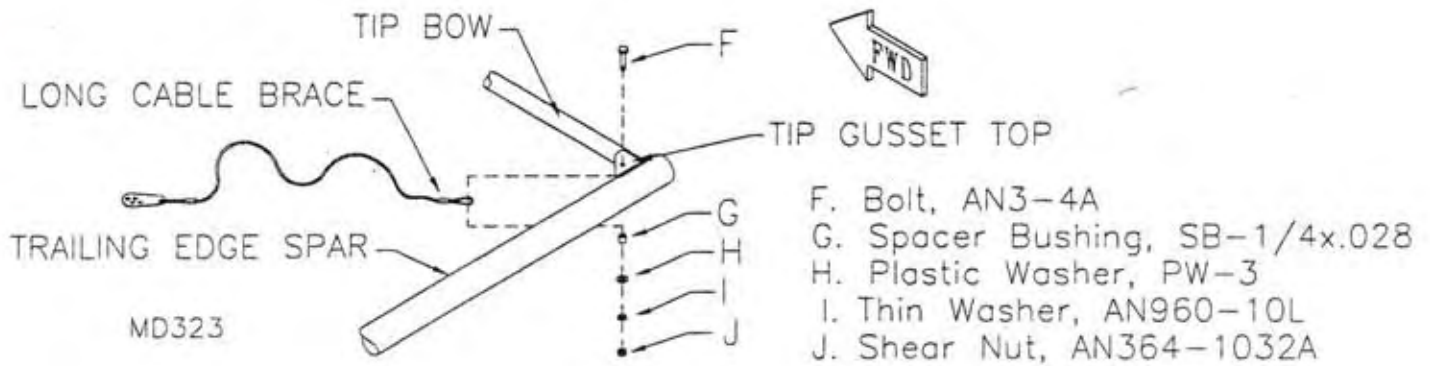
**FIGURE 022-018A**

19. Install the W-WC-50 and W-WC-58 cables used to stabilize the wing tip's last two bays. The W-WC-50 is installed by bolting the shorter cable between the aft spar's S2-SAB at the aft strut plate, and the S2-SAB bracket at the outboard inner compression tube. The W-WC-58 cable is also bolted to the S2-SAB bracket on the outboard inner compression tube and to the wing-tip corner gusset. Refer back to **Figure 022-018A**. First, bolt the thimble end of the **SHORT** cable to the S2-SAB at the aft strut plate using an AN3-16A bolt, plastic washer,  $\frac{1}{4}$ " x  $.028$  x  $\frac{3}{16}$ " bushing, and a  $\frac{3}{16}$ " shear nut. Fabricate the bushings by drilling the raw stock out to #11 and then cutting to length. See **Figure 022-019**. Now insert the AN3-16A bolt up through the other S2-SAB and the compression tube (threads up) and place the adjustable tang of the short cable on the bolt. Place the tang of the **LONG** cable on the bolt using the hole nearest the tang end. With the aft spar and spar tip straight, pull the cable taut and mark the hole location on top of the wing tip corner gusset and drill a  $\frac{3}{16}$ " hole. Remove the nut retaining the tang ends of the cables and slip off the tangs. Next, bolt the thimble end of the long cable to the **UNDERSIDE** of the wing tip corner gusset using the AN3-4A bolt, a plastic washer, a  $\frac{1}{4}$ " x  $.028$  x  $\frac{3}{16}$ " bushing, and a  $\frac{3}{16}$ " shear nut. See **Figure 022-019A**. Place the tangs of both cables back on the bolt. **HINT:** place The **SHORT** cable's tang on top. Place the washer and shear nut back on the bolt. Final secure nut after installing the outboard built-up rib. See **Figure 022-018A**.

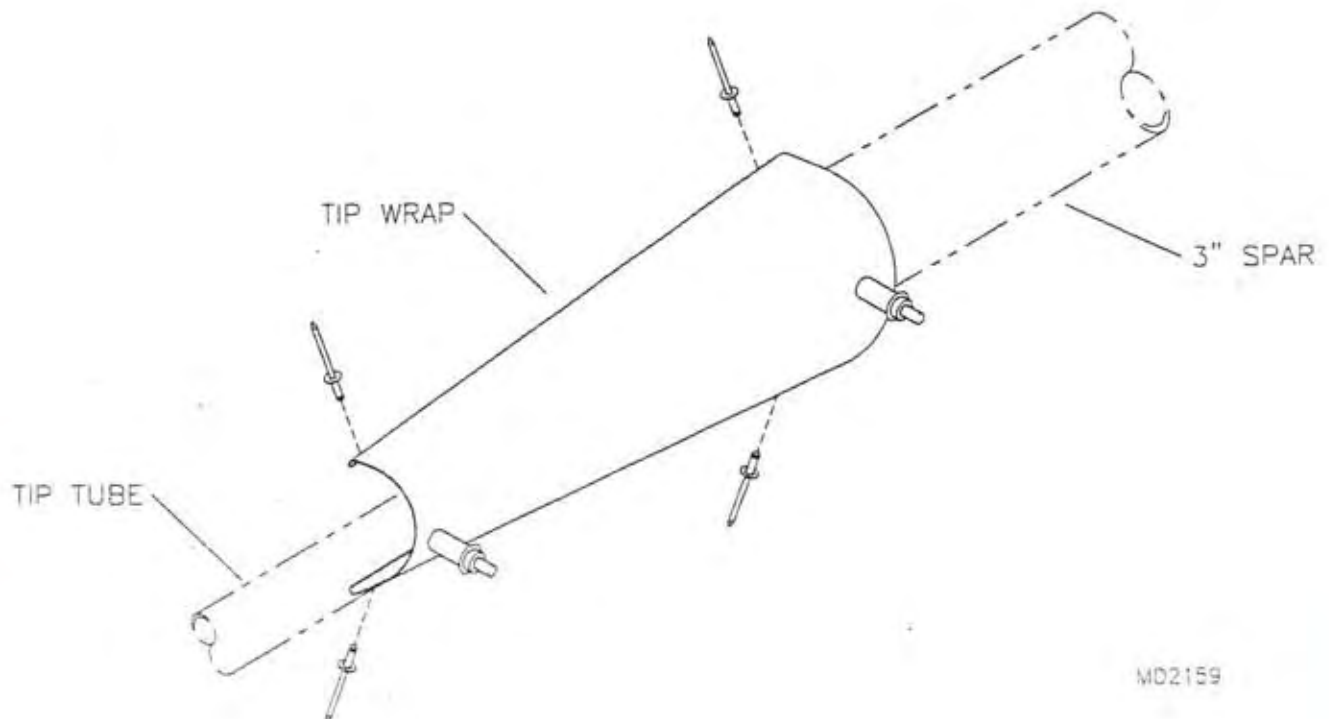
**FIGURE 022-019**

- A. Shear Nut, AN364-1032A
- B. Plastic Washer, PW-3
- C. Spacer Bushing, SB-1/4x.028
- D. Thick Washer, AN960-10
- E. Bolt, AN3-16A

MD323

**FIGURE 022-019A**

20. Shape the tip wraps into half round curves by pressing them over the 3" and 1 3/8" tubes where they are to be installed. Shape the wraps so they flow into the tip without bulges. Overlap the tip wrap onto the spar about 3/8". Center the tip wrap and drill #40. See **Figure 022-020**. Cleco the tip wrap in place. This is only to assist in alignment, **DO NOT** rivet the fwd #40 holes. Working from the middle, pull the wrap together using tape to hold everything together. Drill #30 and rivet the tip wraps to the leading edge spar and tip bow with four (4) 1/8" stainless steel pop rivets.

**FIGURE 022-020**

MD2159

## BUILT-UP RIB INSTALLATION

21. A built-up rib needs to be installed to the outer most compression tube. Insert the duckbill shaped end fittings into both ends of the Tension Top Rib. Dimple the ribs with a center punch to secure the end fittings. Refer to **Figure 11-021**. Place the Root Rib used for the opposite wing between the spars at the tip, up against the inside of the outer most compression tube. Use the root rib as a "contour guide" to place the four (4) tension rib supports. **NOTE:** Open side of supports must face aft. See **Figure 11-021A** and **Figure 11-021B**. The end fitting should fit tight against the spars. Drill #11 the underside of the Top Tension Rib to slip over the compression tube aft bolt. Drill #30 the support ribs and cleco. Remove Root Rib once the tension ribs are fitted with support ribs. Debur and rivet.

**FIGURE 11-021**



**FIGURE 11-021A**

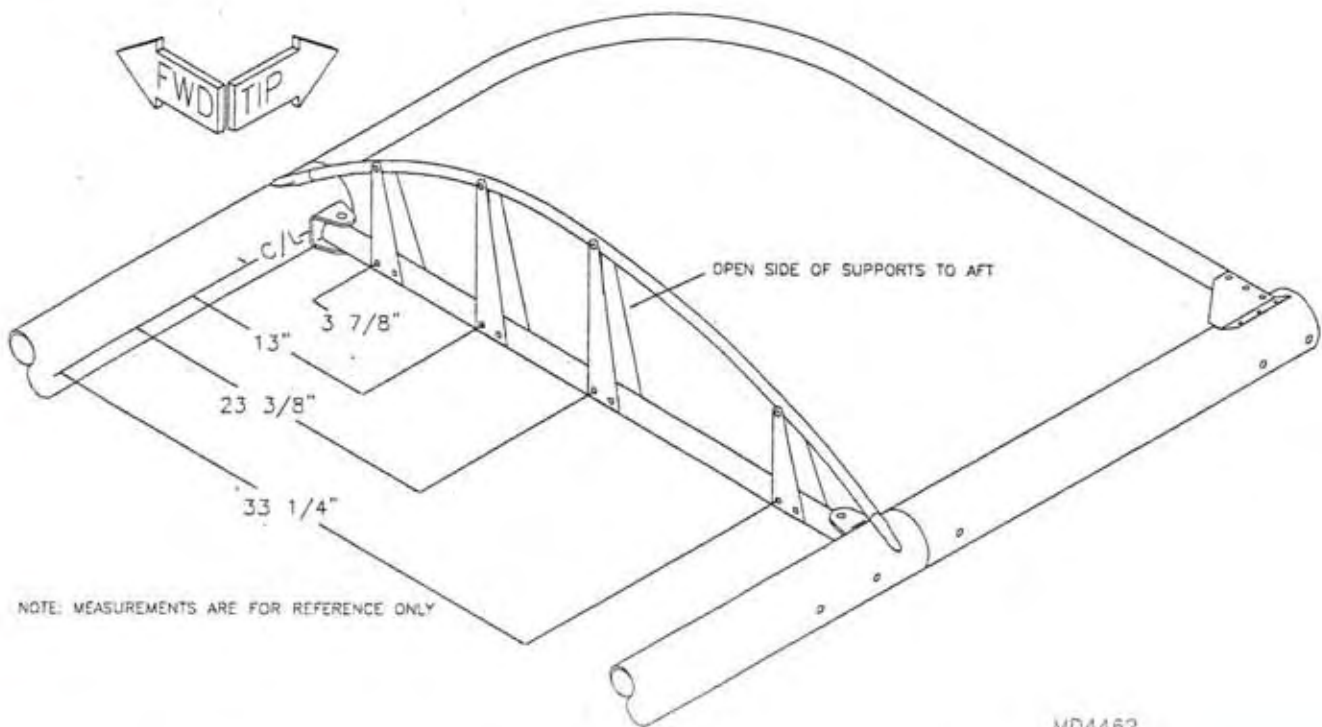
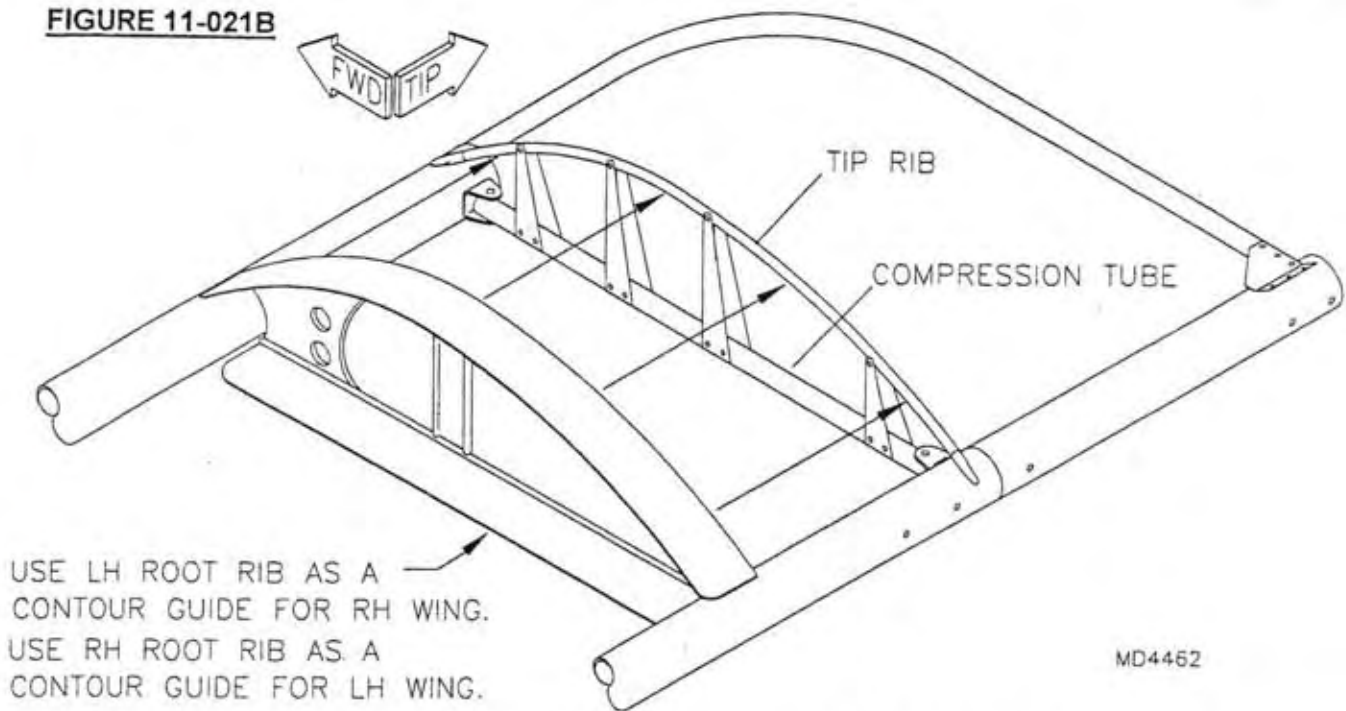


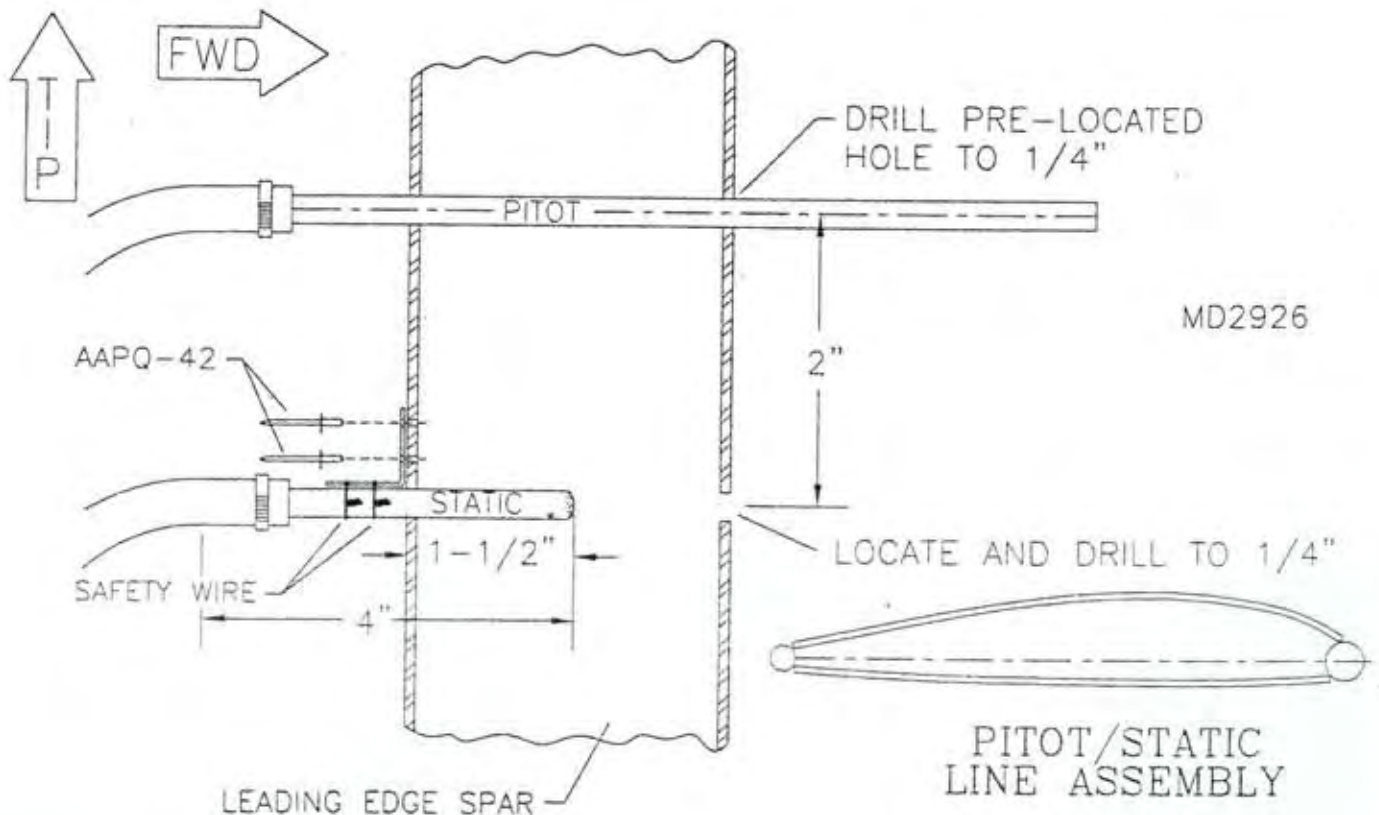
FIGURE 11-021B



### PITOT / STATIC TUBE INSTALLATION

22. Located approximately  $8 \frac{7}{8}$ " from the outer end of the left leading edge spar, is a #11 hole. Drill out this hole in the left hand spar to  $\frac{1}{4}$ " for the pitot tube. Locate and drill another  $\frac{1}{4}$ " hole 2" inboard from the first for the static tube. From the sealed domed end of the static tube, measure 4" and cut the excess length off. Insert the static tube into the inboard most hole so that it extends into the leading edge spar  $1 \frac{1}{2}$ ". Position the aluminum L bracket next to the static tube as shown in FIGURE 022-022. With a #30 drill bit, transfer drill through the L bracket into the spar and rivet in place. Safety wire the static tube to the L bracket.

FIGURE 022-022



23. Install the pitot tube completely through the outboard most hole. Attach the static and pitot line to both the static and pitot tubes in the spar. Route both lines on top of the internal compression tubes and exit the wing at the trailing edge with approximately 24 inches extending beyond the root of the wing. Using zip ties, loosely tie the lines to the compression tubes in 2 or 3 locations. Be very careful to not pinch or restrict these lines with the ties. **IMPORTANT:** For accurate airspeed readings the static probe must be set inside of the spar tube. The airspeed should be checked against a timed mile flown in no wind. Pitot tube must extend out of spar at least 8". When folding wings, pitot tube can be pushed into wing with 1" extended. Return to the 8" mark before flight.

## TURN TO THE FUEL SYSTEM FOR ASSEMBLY DETAILS BEFORE CONTINUING.

In the next section we discuss setting up the ailerons and flaps. You may want to do this with the wings attached, if so, turn to the root rib assembly followed by the strut assembly. This will bring you up to the point where the wings are on the plane setup with the correct washout and dihedral.

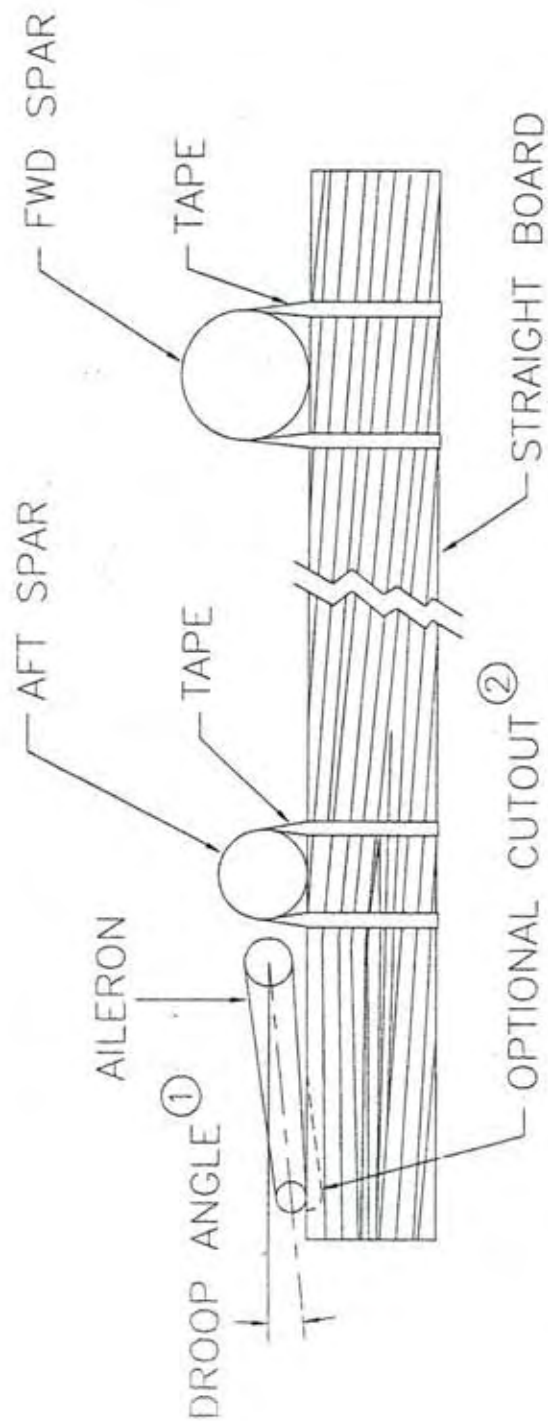
## RIGGING THE FLAPS AND AILERONS

24. To set the aileron rigging, attach the ailerons and flaps to the wing using the hinges. Put the ailerons and flaps on the side of the hinge that gives the best matched fit. Only finger tighten the nuts to the hinge bolts at this time.

25. Apply a drop of loctite and screw the male rod ends into the ends of the push pull tubes until bottomed against the threads. Install a stop nut on the bellcrank end of the short push pull tube or bottom it out against the rod end. The short push pull tube is screwed into the rod ends attached to the bellcrank after covering the wing. Install the aileron push pull tubes using the hardware depicted in the aileron push pull tube parts drawing. **IMPORTANT:** The long push pull tube bolts to the **TOP** of the aileron bellcrank. The short push pull tube bolts to the **BOTTOM**.

26. Before beginning rigging of the ailerons check the control stick and control tee. The control tee must be centered when the sticks are neutral. If this is not the case review rigging instructions for the control stick and tee under control stick assembly. With the control tee centered adjust the long push pull tubes so the bellcranks are in the neutral position. Refer to **Figure 022-015A**. Find two very straight boards at least 60" in length. These will be used to set the droop angles of the flaps and ailerons. The droop angle is shown in **Figure 022-026**. Firmly tape the boards on the bottom of the wing spars. Let the boards overhang off the AFT spar at least 8". The aileron trailing edge should rest on the board to set the proper angle of droop. Adjust the rod ends on the short aileron push pull tube until the aileron is set. **IMPORTANT:** The rod ends must be screwed into the ends of the push pull tubes a minimum of 10 turns to have acceptable strength for flight loads. Remove the boards once both ailerons are set. Test the system by displacing the control stick side to side. The aileron bellcranks are set up to displace twice as much up as down. You can check this very simply by measuring the difference from the neutral position up and down. If this is not the case it means the bellcrank was not at the neutral point. Refer to **Figure 022-015A** to check for the neutral bellcrank position. Use blue loctite to keep the push pull tubes in setting. Remove the short push pull tube to allow installation of the wing covering. After the wing covers are attached, apply a drop of blue loctite to the end of the forward push pull tube. Screw it into the rod end that was left attached to the aileron bellcrank.

FIGURE 022-026



- ① Drop angle of the aileron and flaps is established when the aileron's trailing edge rests on the board.
- PLEASE NOTE: This is the recommended "start" setting. After flight test you may want to droop more for low speed or raise for cruise.

- ② Cut out guide board  $1/4"$  to  $3/8"$  if lower stall speed is desired.

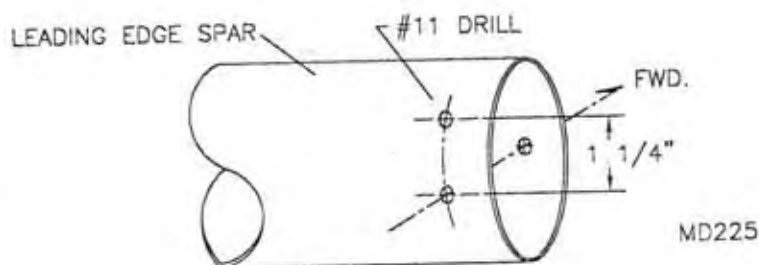
MD316

## INSTALLING THE ROOT RIB TENSIONING SYSTEM

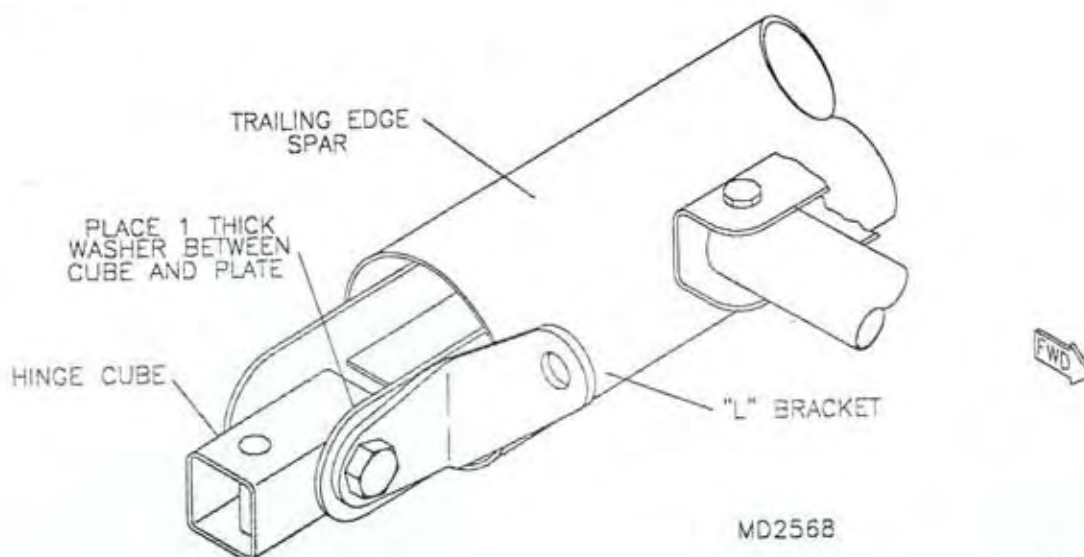
The wing skin is attached and tensioned span-wise using a prefabricated root rib. The root rib comes ready to install with the exception of the holes for the 8x1/2" PHS. Notice that all the pre-located holes are pre-drilled to a #40. Drill these to a #28 and debur any rough edges. This rib is attached to the wing through two "L" brackets and bolts. These bolts are threaded into the root rib. When the bolts are tightened the root rib moves inboard pulling the wing fabric tight.

1. Collect all the parts depicted in the parts drawing for the root rib.
2. Place the root rib in the wing with the wing skin flush to the inboard side of the root rib. Prepare the leading edge spar as shown in **FIGURE 022A-02**. Bolt the brackets to the leading edge spar and the inboard side of the universal hinge on the trailing edge spar as shown in **FIGURE 022A-02A**. Thread the bolt and washer through the leading edge bracket and root rib into the hole provided. Install the nut and washer on the inside of the root rib. **NOTE: Do not tighten the bolts at this point.** Position the root rib against the brackets. Transfer drill 1/4" through the trailing edge bracket and root rib. Thread the bolt and washer through the trailing edge bracket and root rib. Install the nut and washer on the inside of the root rib. **NOTE: Do not tighten the bolts at this point.** Line up the wing skin and Velcro so they are properly centered on the trailing edge spar and the entire wing. **NOTE: See the covering section for details.** Install the 8x1/2" PHS through the wing skin and pre-drilled holes in the root rib. Use an icepick or a small awl to transfer the predrilled holes from the root rib through the wing skin edge webbing. Start installing the 8x1/2" PHS screws in the center of the root rib, working to the end of the rib. The root rib is curved inboard to assure the rib will be straight when installation is complete. Flip the wing and repeat on the bottom side. When screws are installed, begin to tension bolts. Tighten to 3/8" from the inside edge of the "L" brackets. **Caution: Do not over-tighten the tensioning bolts. Stop when the skin is tight, if within 3/8" of the bracket.**

**FIGURE 022A-02**



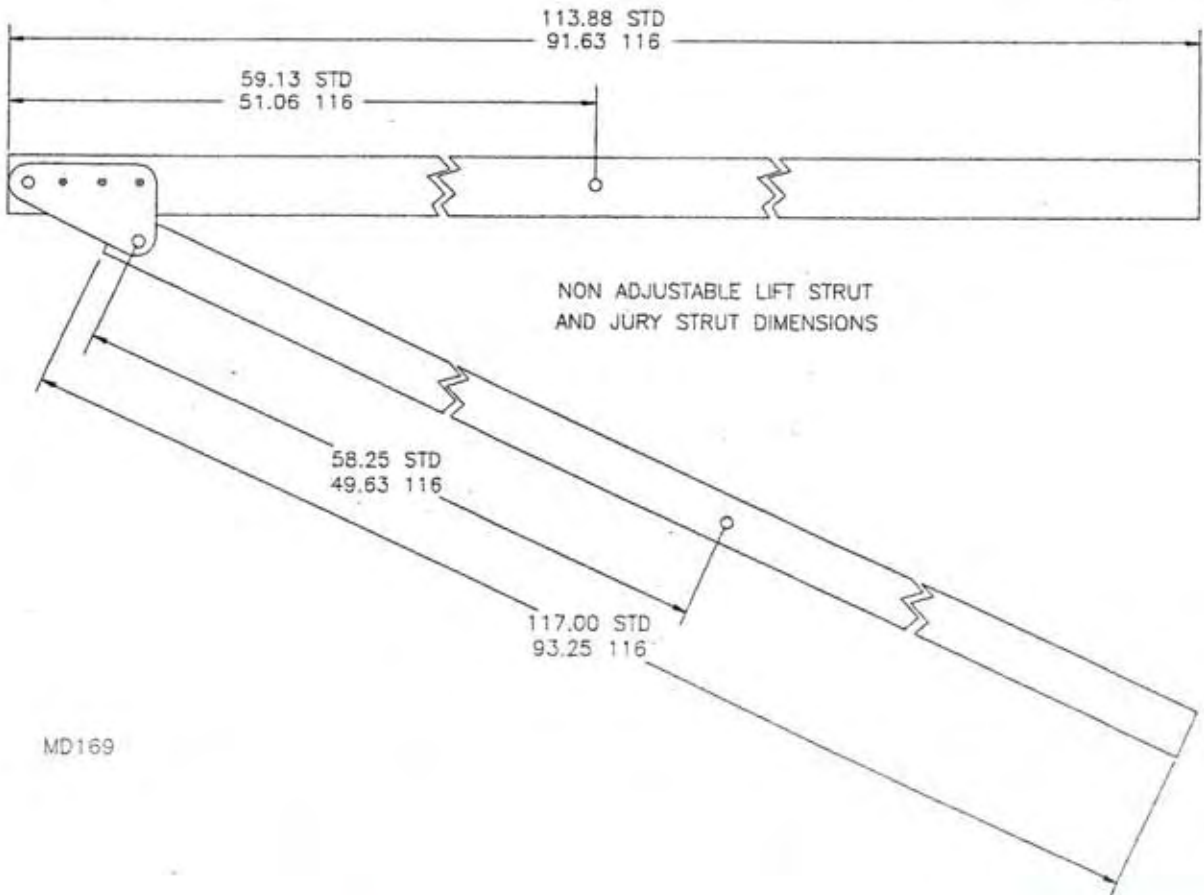
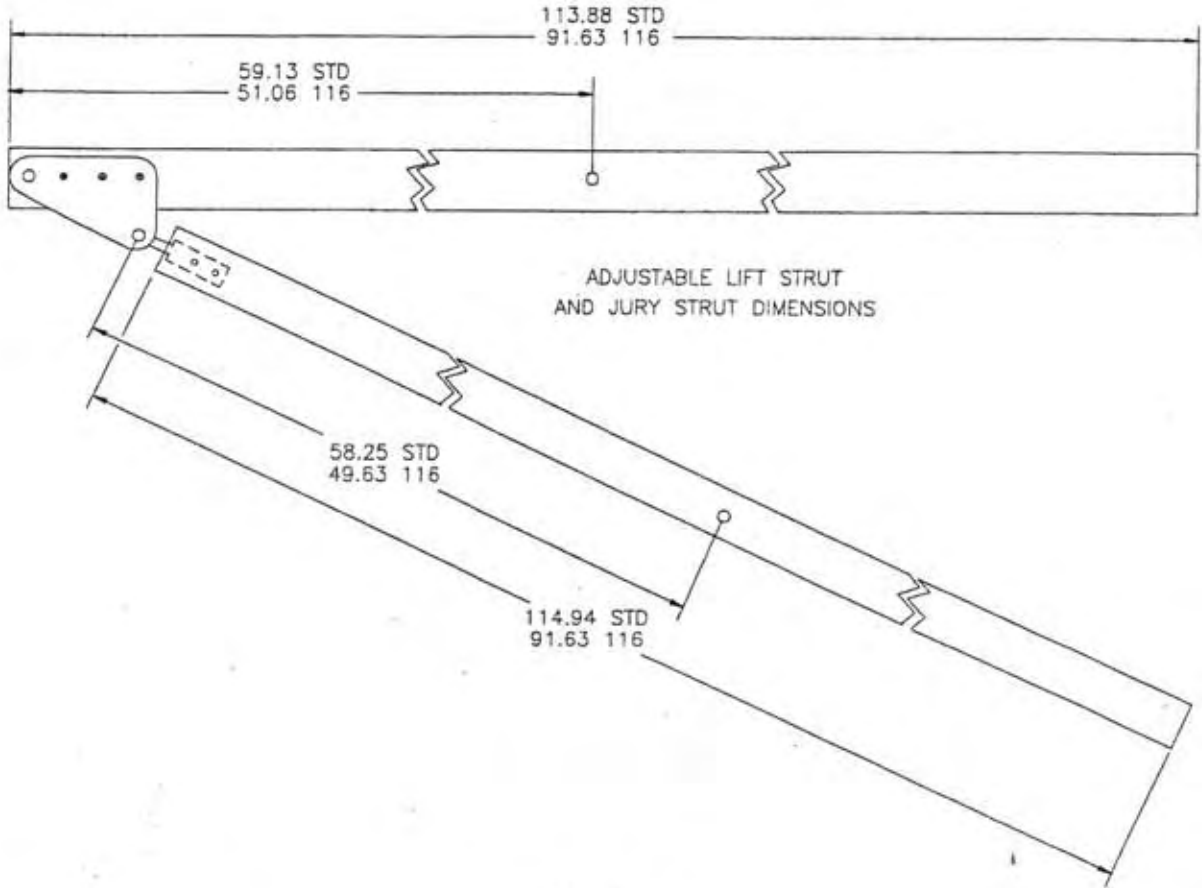
**FIGURE 022A-02A**



## INSTALLING THE ROOT RIB SKIN

1. Position the root rib skin against the root rib assembly. *NOTE: Align the notches in the root rib skin with the rivets retaining the root rib channels.* Transfer drill #30 the skin and rib. Cleco as you drill.
2. Install the rubber grommets. These protect the fuel sight gauge tubing. During final assembly install the sight gauge, fuel level decals and rivet the root rib skin to the root rib.
3. Apply an anti-chafe material to the aft end of the root rib skin as required.





MD169

## INSPECTION OF THE AIRFOIL LIFT STRUTS

RANS airfoil lift struts are made of extruded aluminum. Extrusions of this nature are sensitive to deformation. Cracks and splits can occur along the length of the strut if the ends are compressed beyond the material limits. Over tightened bolts can cause cracking. A compression bushing or fitting large enough to equal the struts inside diameter should be used. Remove any of the burrs that may be on the ends of the tubing before cutting bushings to fit.

Each and every piece of airfoil strut material is inspected two times before shipment to assure you of a quality product. However, we are not infallible, therefore, we encourage you to inspect the material for any form of deformation and surface imperfection. Deeply grooved struts should not be used and returned to the factory for replacement. The surface should look and feel smooth.

Dents and nicks can occur during shipping. The strut material is very thick skinned and resistant to dents. If dents are present they will usually be large enough to require rejection of the material.

Minor nicks and scratches can and should be sanded out with 250, 350 and then finally 400 grit wet or dry sandpaper. Sanding out such defects is an effective way of restoring the strut to a safe full strength status. Any nicks or scratches that need more than light sanding are cause for rejection.

Once the struts are in service, continued inspection is the only required maintenance action. Anodized strut material is resistant to corrosion and needs little care. However, non-anodized material will corrode in a salt air environment and it should be protected inside and out. External protection can be effected using epoxy paints or other high grade finishes. The inside of the strut can be protected with paint by pouring a quantity of paint inside the tube and rotating to cover the entire surface.

Include strut inspection in your pre-flight check.

## STD/116 STRUT INSTALLATION & SETTING WING WASH OUT

**PLEASE NOTE:** It is assumed the wings are assembled but not covered and the fuselage is sufficiently complete. If you are installing the optional adjustable strut fitting, read the standard procedure through and then read the instructions for the adjustable lift strut fittings in this section.

With the help of a friend and two step ladders or similar devices about the height of the main spar carry through, bolt the wings to the fuselage. Hold up the tips with the ladders.

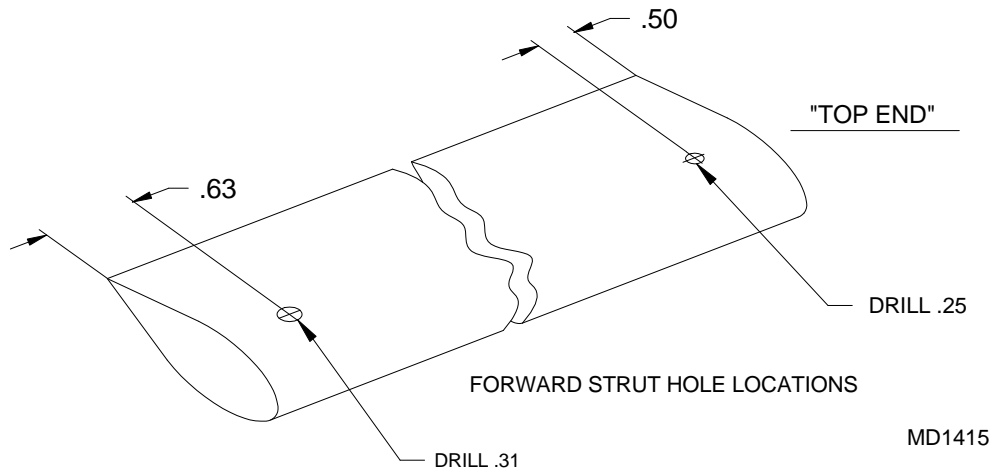
A. The T-bone is what we call the leading edge spar attach point at the fuselage. It will need to be ground to fit the inside diameter of the leading edge spar. To get the best fit bolt the rear spar to the fuselage through the universal hinge. Swing the wing up to the T-bone and take note of how much needs to be ground off to fit. The spar must fit over the T-bone across the diameter of the tube, lower or higher. Grind or file and test fit. Repeat this until the leading edge spar slips easily over the T-bone. If you take off a little too much it presents no problem. Up to an 1/8" gap is acceptable between the T-bone and the inside diameter of the spar. The main idea is to allow the spar to slip on and off the T-bone without scratching up the spar.

B. A single #11 hole is drilled into the front side of the leading edge spar for locating the 3/8" clevis pin. Swing the spar into position with the #11 hole placed over the T-bones' 3/8" bushing. Drill out the #11 hole with a 3/8" drill into the T-bone bushing. **IMPORTANT:** Support the wing tip while drilling. If the wing is not properly supported it will cause the hole to elongate while drilling. Once you have drilled through the front side of the leading edge spar, drill through using the T-bones' 3/8" bushing as a guide to drill out the other side. Insert the 3/8" clevis pin from the front and install the loc ring.

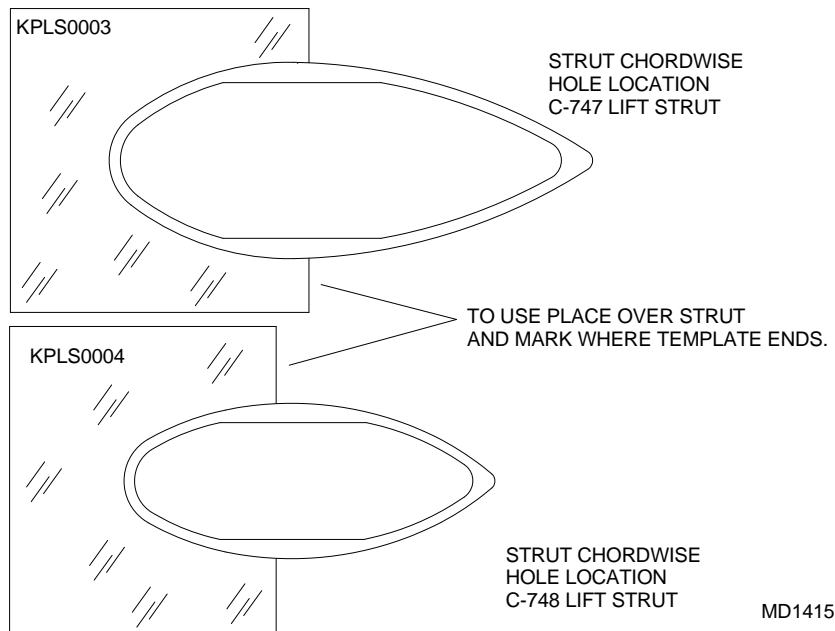
1. Select the parts depicted in the part drawing.

2. Take the two larger struts and locate and drill a 5/16" hole 5/8" in from one end and a 1/4" hole 1/2" from the other. A second hole will be drilled in the 1/4" hole end, this will become the "top" end. Use the templates shown in **Figure 022B-02A** to locate the exact position of the holes crosswise on the struts. See **Figure 022B-02** for hole locations. Due to dimensional variation in extruded material it may be required to shim the fittings. No gap should exist between the fittings and the struts. If there is a gap, it should not be eliminated by tightening down the bolts. If a gap exists this action may crack the struts. Instead, use the .020 shim material to insure a tight fit. At the root fittings of the lift struts, washers or shims may be required. See **Figure 022B-02C** for guidelines to make these shims. Assemble the fittings to each end as per the parts drawing installing gusset plates using **Figure 022B-02B** for reference. **NOTE:** Drill out the fitting 5/16" as required. Rivet the gusset plates to the forward lift strut with 3/16" stainless steel pop rivets.

**FIGURE 022B-02**



**FIGURE 022B-02A**



**FIGURE 022B-02B**

MD1261

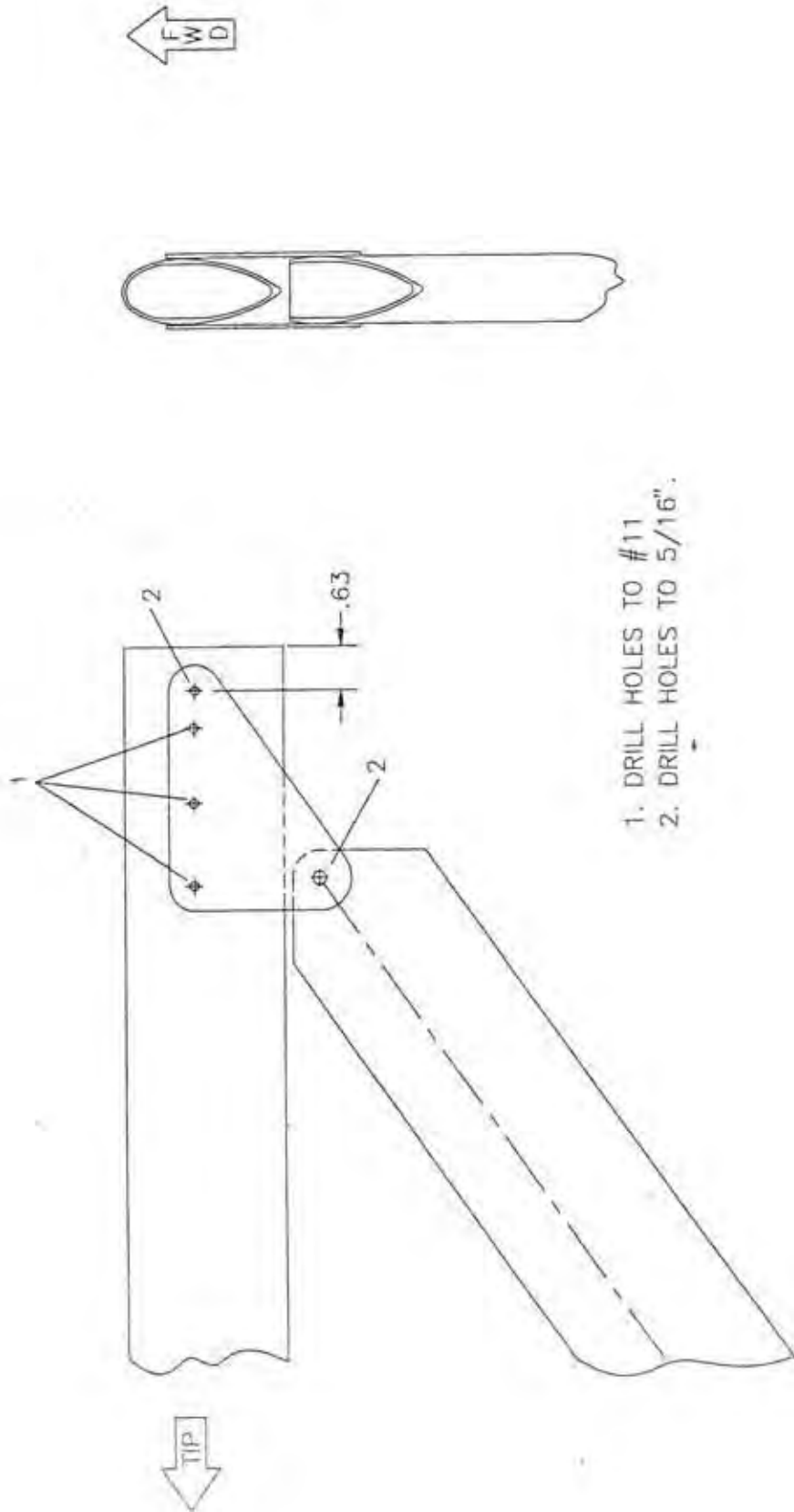
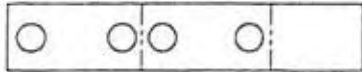
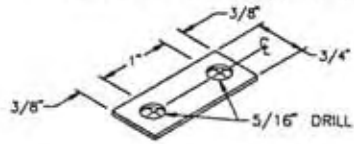


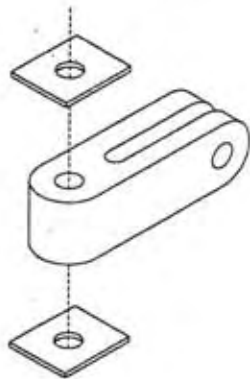
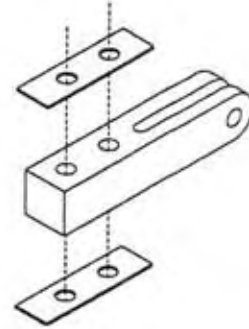
FIGURE 022B-02C

# S-6ES LIFT STRUT SHIMS

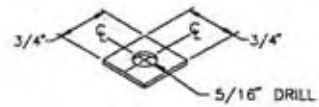
UPPER FWD STRUT SHIM



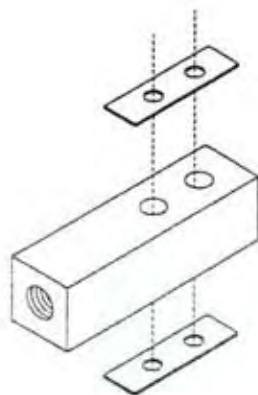
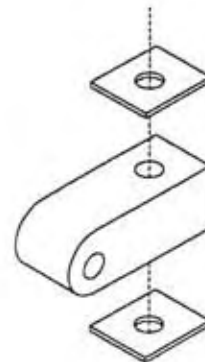
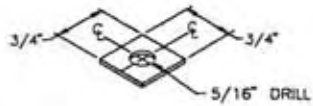
HINT: DRILL HOLES IN SHIM STRAP THEN CUT TO LENGTH. MAKE AS REQUIRED.



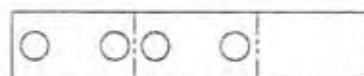
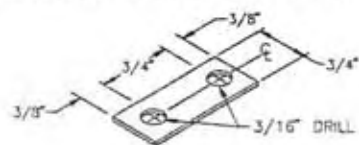
UPPER AFT STRUT SHIM



LOWER FWD STRUT SHIM

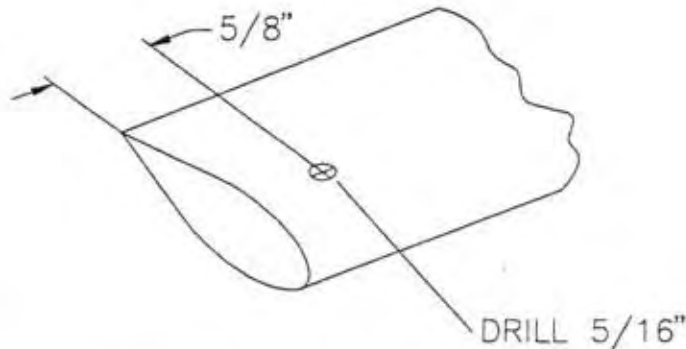


OPTIONAL ADJUSTABLE STRUT SHIM



3. Drill the AFT lift struts on one end only to a diameter of 5/16" at an edge distance of 5/8". See Figure 022B-03. Be sure to use the hole locator to position the hole on the strut chordwise.

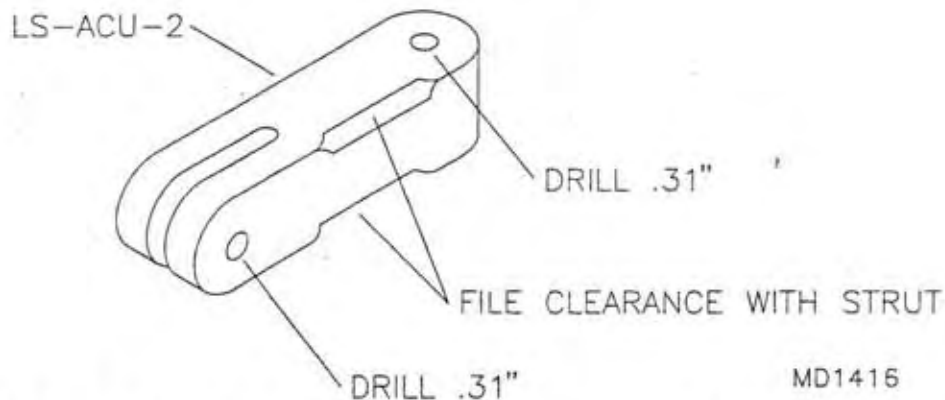
**FIGURE 022B-03**



4. Drill out the two #11 holes to 5/16", see Figure 022B-04.

MD1416

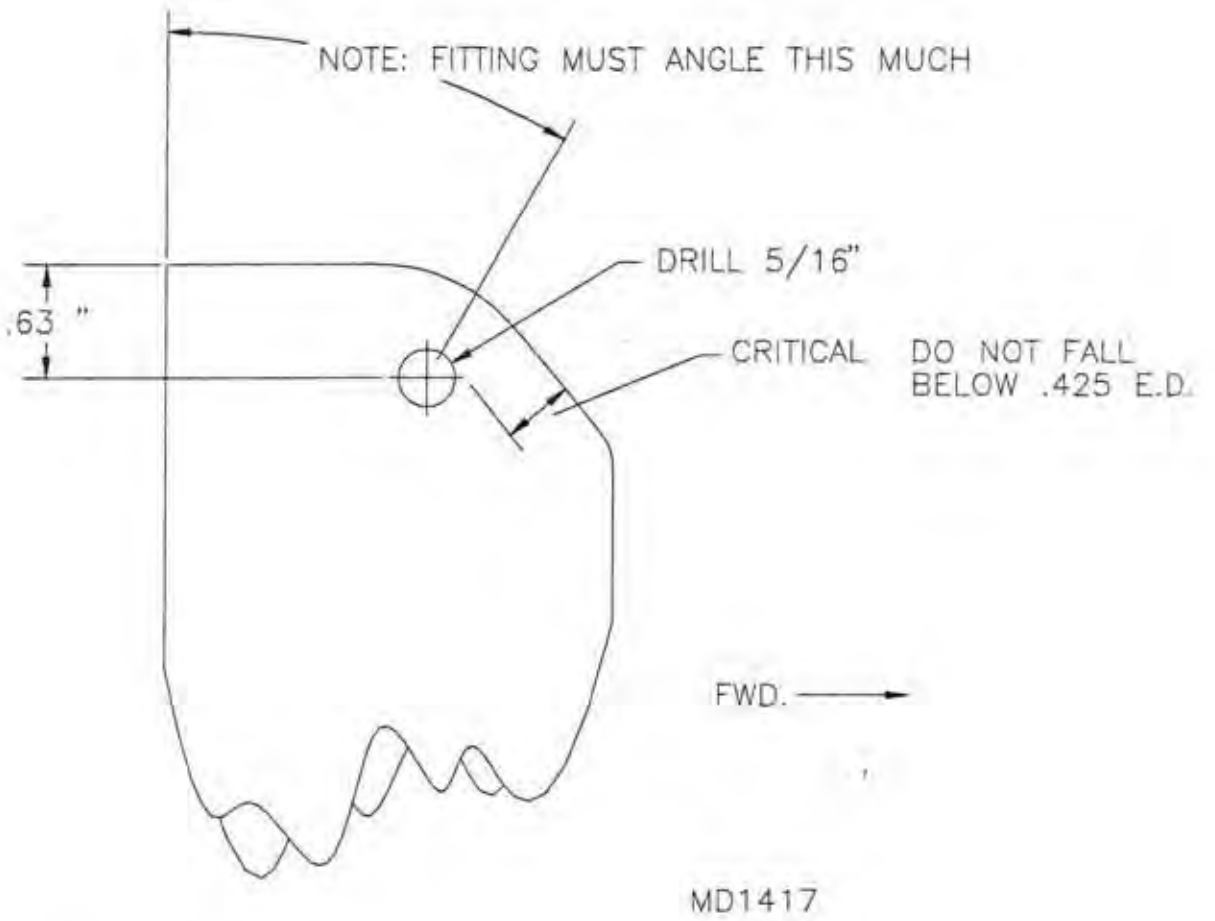
**FIGURE 022B-04**



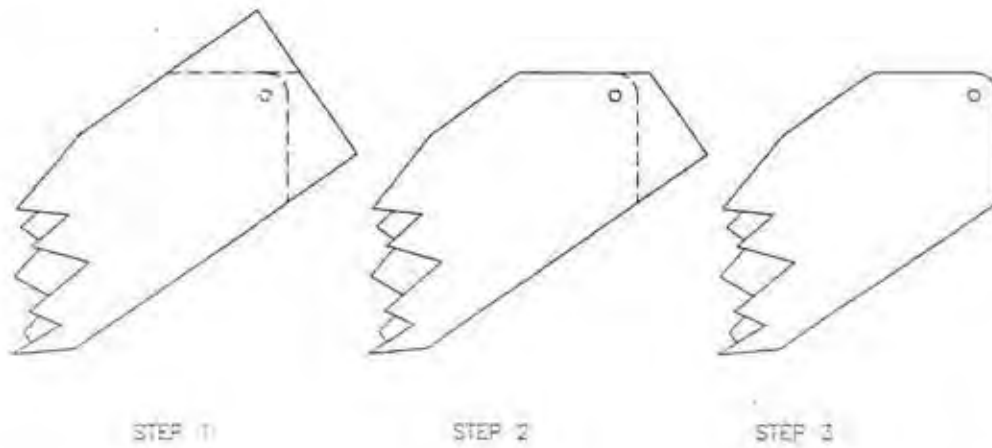
MD1416

5. Trim the AFT lift strut top end as shown for fitting clearance in Figure 022B-05.
6. Bolt the fittings into the AFT lift strut top ends. Shim as required.
7. Bolt the forward lift struts in place with the AFT lift strut gussets point AFT. The forward lift struts automatically set the dihedral.
8. Use the template as shown in Figure 022B-02A to mark a line for several inches at the strut's lower end showing chordwise location for the hole. Rough trim the lower end of the strut to the shape as shown in Figure 022B-08. **NOTE:** To trim and drill the ADJUSTABLE LIFT STRUTS use Figure 022B-08A as a trimming guide. Bolt the AFT lift struts to the wing and place the undrilled end between the gussets. **PLEASE NOTE:** The wash out will be set by twisting the wing. The proper twist lifts the rear spar higher than the forward. The AFT strut will be clamped and drilled at the gusset once the wash out is set. The gusset will act as a drill guide. Install the anti-crush bushing inside the lower AFT strut. **IMPORTANT:** No gap should exist between the fittings and the struts. If there is a gap, it should not be eliminated by tightening down the bolts. If a gap exists this action may crack the struts. Instead, use thin washers or file the crush bushing to insure a tight fit.

**FIGURE 022-05**



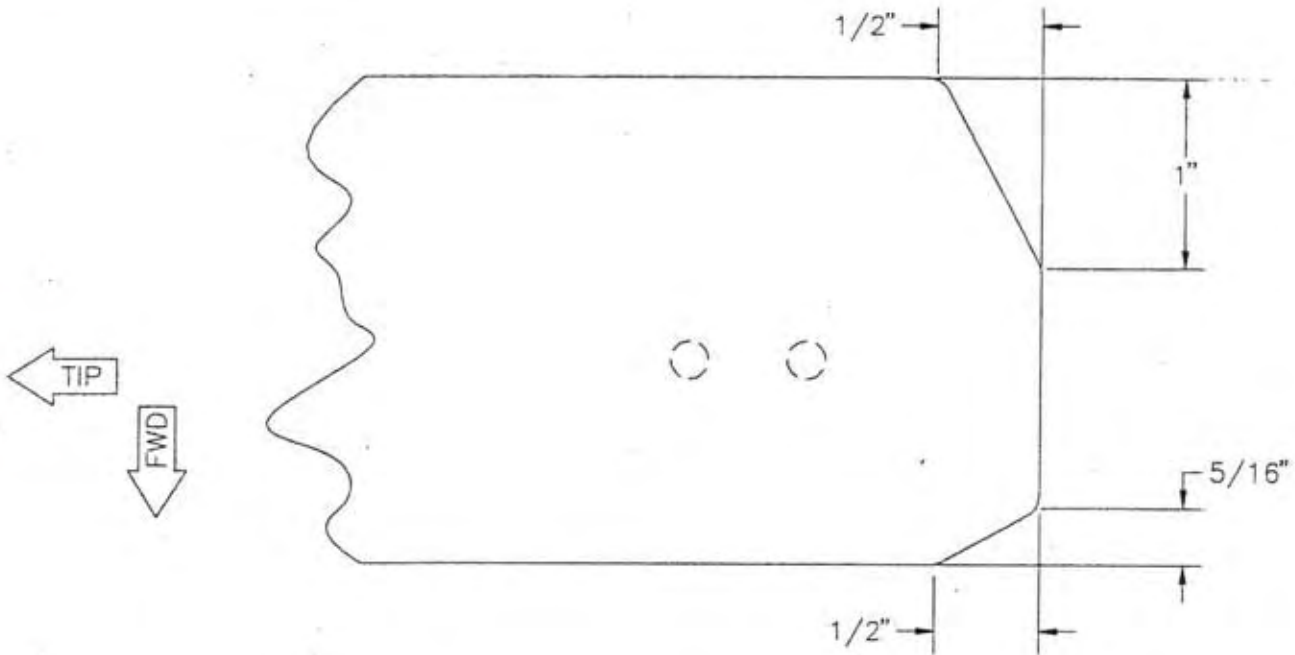
**FIGURE 022B-08**



MD1417

**FIGURE 022B-08A**

ADJUSTABLE LIFT STRUTS

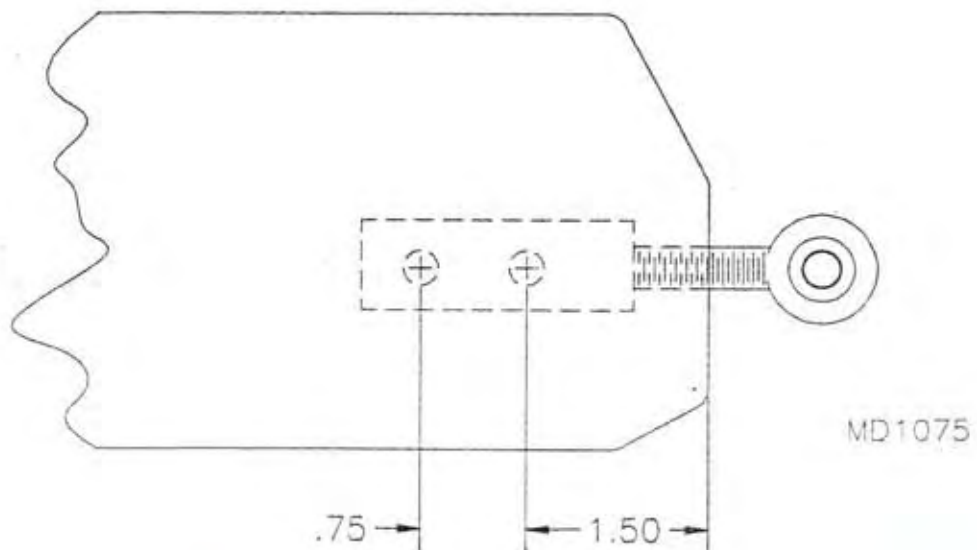


TRIM LOWER END OF EACH AFT LIFT STRUT AS SHOWN.

MD1076

9. For the adjustable lift strut option refer to **Figure 022B-09** for dimensions to use as a guide in setting up the rear lift strut.

**FIGURE 022B-09**



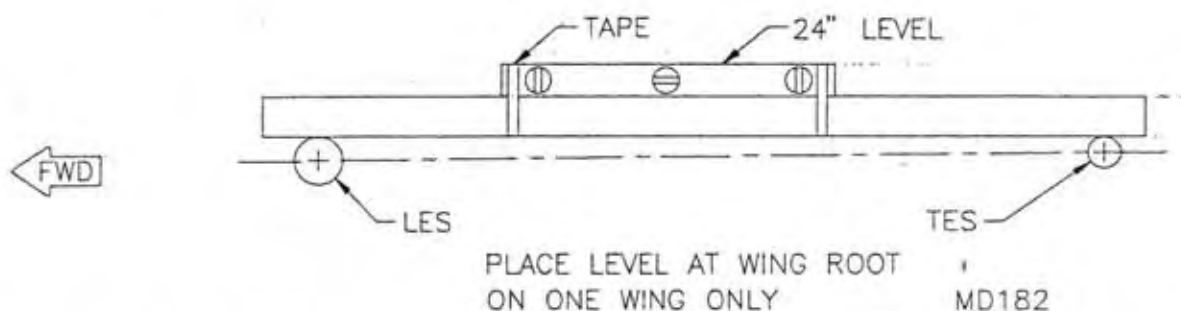
MD1075



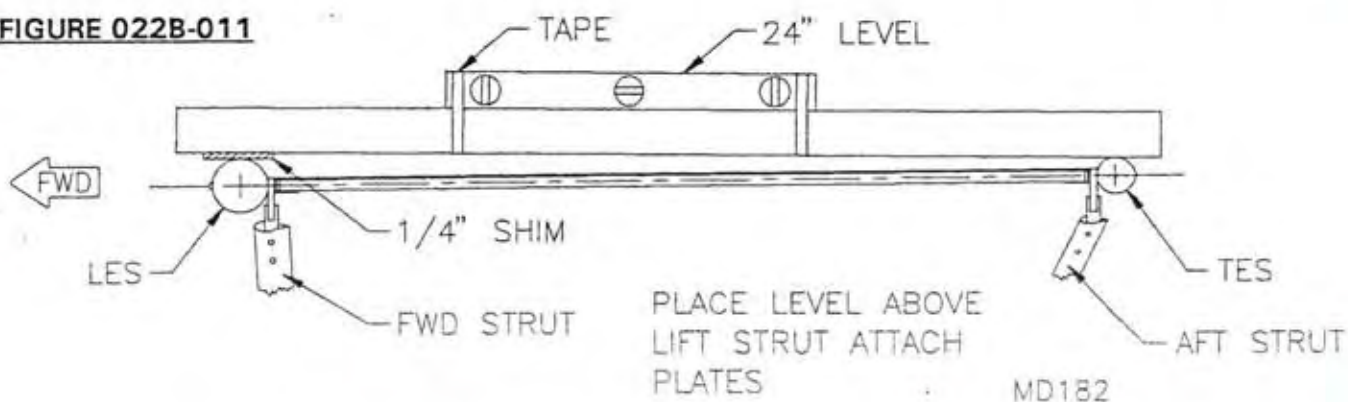
**NOTES:**

- A. Forward strut sets up with the same fittings as standard.
- B. Cut AFT strut to length.
- C. Trim lower AFT strut (use Figure 022B-08A as a guide).
- D. Install upper strut connector as normal.
- E. Install adjustor block as shown.
- F. Hook up strut and adjust rod end.

10. Make a rigging level by taping a 2 foot level to a straight 50" long, 2" X 3/4" board. Place the level on the wing's topside at the root. The level should be held against each spar. Raise the main gear until it reads level. **CAUTION:** Block wheels to prevent rolling. Double check the level prior to step #10. See Figure 022B-010.

**FIGURE 022B-010**

11. Cut out a scrap of 1/4" plywood 6" X 2" and nail or screw it to one end of the straight edge. Place the rigging device just outboard of the right wing's struts with the 1/4" block on top of the forward spar. See Figure 022B-011. This will set the "wash out". Move the AFT spar up or down as required to obtain a level reading. Use a vise grip type "C" clamp to hold the setting. Check for accuracy before drilling. Mark on the fitting with a pencil where the lower end of the strut is. Use the gusset fitting to line up on the mark and the chordwise marks to drill the bolt hole. Drill 5/16", then assemble. Be sure to place the anti-crush bushing on the inside of the AFT strut lower fitting. Remove the pencil marks afterwards or the graphite will cause corrosion.

**FIGURE 022B-011**

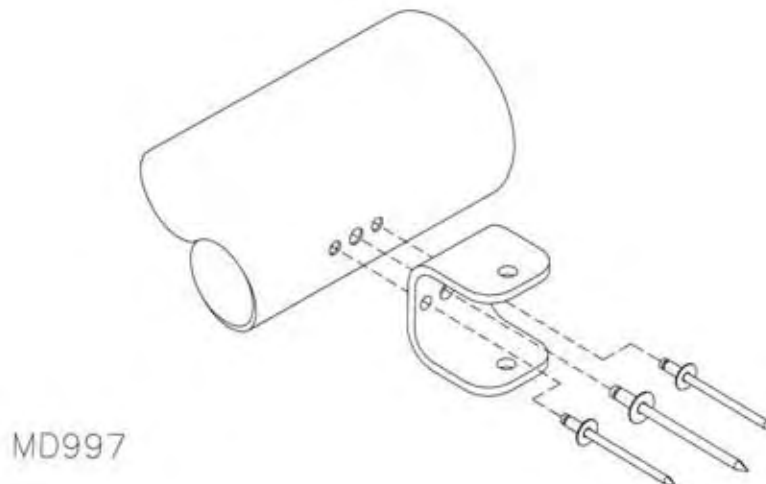
12. Go directly to the other wing's outboard strut location and set the wing. It is not required and can even result in an improper setting if another level reference is taken from the other wing root.

## S-6ES COYOTE II 116 WING ASSEMBLY

**LEADING EDGE SPARS.** While assembling spars, keep in mind that one must be assembled as right (RH), the other as left (LH).

1. Select parts depicted in parts drawing.
2. Leading edge spar comes with all holes pilot drilled; final hole sizes are called out during assembly. **NOTE:** Forward side of spar has three holes for tip bow rivets; fourth hole on left spar will be size drilled to 1/4" to accept pitot tubes. The #11 hole 5-5/8" outboard from the root indicates AFT side.
3. Bolt long wing channel to first hole 45 5/8" outboard of root. Position channel with bolted end toward root. Align channel along spar, drill and secure with 3/16" stainless steel rivet through remaining holes. (Only drill through the one side of spar.) **HINT:** Lay a straight 1" tube between the S2-SAB and channel to aid in alignment.
4. Install strut attach plates. For best accuracy, place attach plate against spar holes and use as a template. It is best to drill through with a 1/4" drill and bolt, then drill the other two holes to 23/64"; drill from each side, not from one side through to the other. Debur and install 3/8" x 3" bushings, 1/4" bolts, strut attach plate and wing channel, as shown in the parts manual.
5. 2 1/2" from tip of leading edge spar (LES), on aft side, is a #11 hole. Rivet an S2-SAB to the spar using a single 3/16" stainless steel pop rivet. Drill a #30 hole to each side of the 3/16" rivet. Rivet with #30 stainless steel rivets. See **Figure 022C-05**. Do the same for the S2-SAB on the trailing edge spar. The outboard compression tube (W-IO) will bolt to this bracket. On the LES root end is a #11 hole (spar's aft side) 5 5/8" outboard. Using a #11 stainless steel pop rivet attach a S2-SAB.

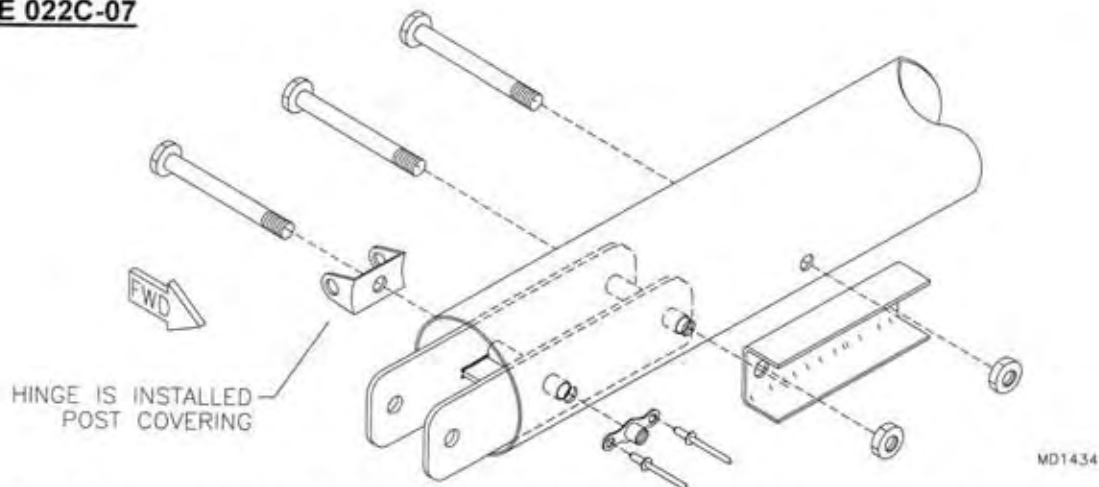
**FIGURE 022C-05**



## TRAILING EDGE SPAR ASSEMBLY (SPARS HAVE A FRONT & BACK)

6. Bolt a long wing channel to the two #11 holes drilled through the spar at 3 3/4" and 6 3/4" from the root end. **NOTE:** The inner bolt is used to retain the universal hinge bracket; do not tighten till next step.
7. Collect the parts shown in the universal hinge drawing. Fabricate the aluminum bushings by cutting from raw stock; deburr. Press the bushings into the bushings of the spar fitting. If the bushings do not press in, glue them in using a dab of J&B weld. Test fit the fitting into the end of the spar. It most likely will need to be ground to contour the spar's inside diameter. Assemble the hinge to the trailing edge spar's inboard end. Use the first and second bolts at the spars root to attach the fitting. The bolt that attaches the hinge cube is used to attach one "L" bracket. The "L" bracket is used for the root rib tensioning system; only finger tighten the bolt at this time. Rivet a 3/16" nut plate to the front side of the rear spar for the first inboard bolt. This bolt is used as a flap hinge point. The nut plate is required due to wing covering limiting access for nutting. See **Figure 022C-07**.

**FIGURE 022C-07**



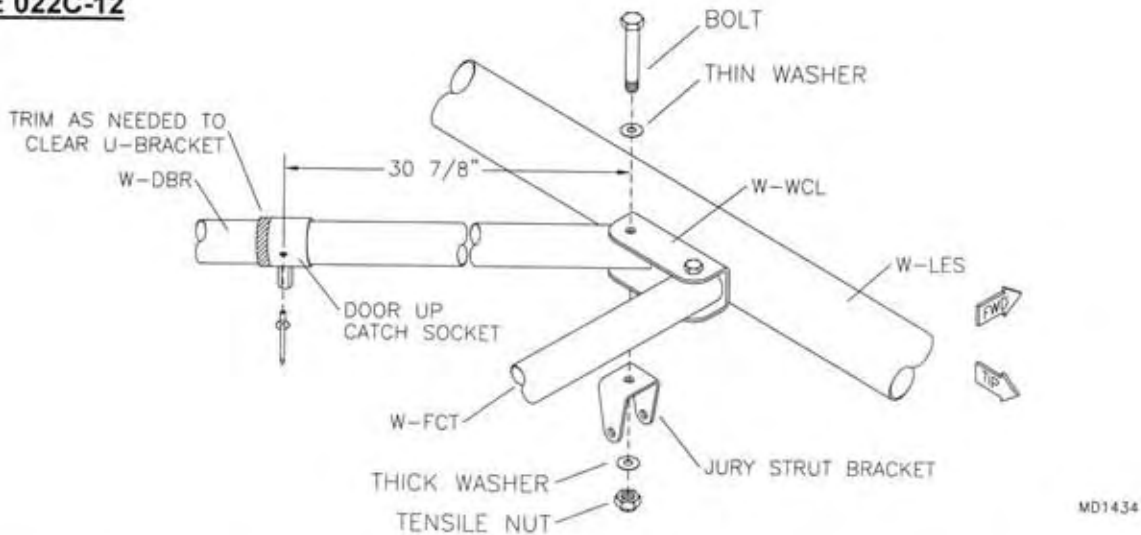
8. Bolt a long wing channel to the trailing edge spar at the hole 46 5/8" outboard of the root end. Position the unbolted end to the **TIP** side. Line up the channel parallel and drill and rivet with 3/16" stainless steel pop rivets.
9. Drill the three holes for strut plate attachment following the procedure in step 4.
10. From the parts drawing determine the location of the lower hinge bolt and rivet on the front side of the spar a 3/16" nut plate. Position the nut plates so the rivets are parallel with the spars.

## INTERNAL BRACE TUBES AND AILERON PUSH PULL TUBE ASSEMBLY

(Refer to control stick for selection of parts.)

11. Refer to wing internal bracing tubes and select the parts for assembly.
12. Install the drag braces. **NOTE:** Before installing the W-DBR, slip the door up catch on prior to bolting in place. This up catch should be located 30 7/8" from the W-DBR's 3/16" bolt center to the center of the up catch. See **Figure 022C-12**. Before bolting the middle compression tube in place, slip on the aileron bellcrank doubler. The aileron bellcrank doubler is a 3" to 4" tube and 1 1/8" in diameter. Bolt the flap compression tubes with the hole for mounting the Teleflex retainer closest to the trailing spar.

**FIGURE 022C-12**



13. Locate Aileron Push Pull Tube Guide on second Outboard Compression Tube, as per **Figure 022C-13**. Install the Teleflex Retainer Bracket to the inside of the Flap Compression Tube as shown in the parts drawing. Note the position and orientation of the bracket. See **Figure 022C-13A**.

**FIGURE 022C-13**

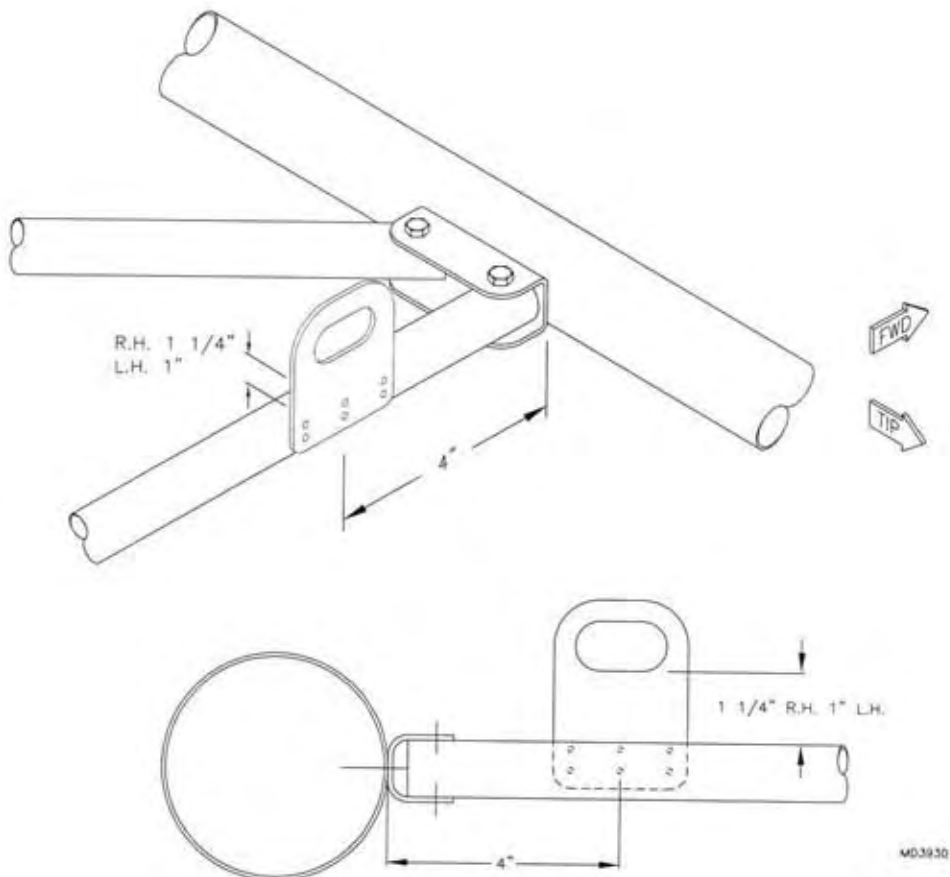
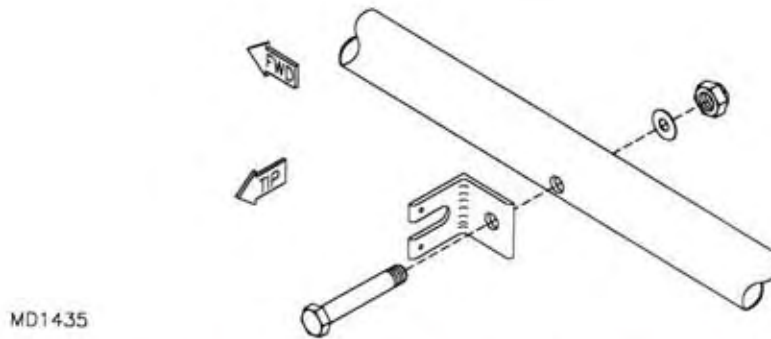
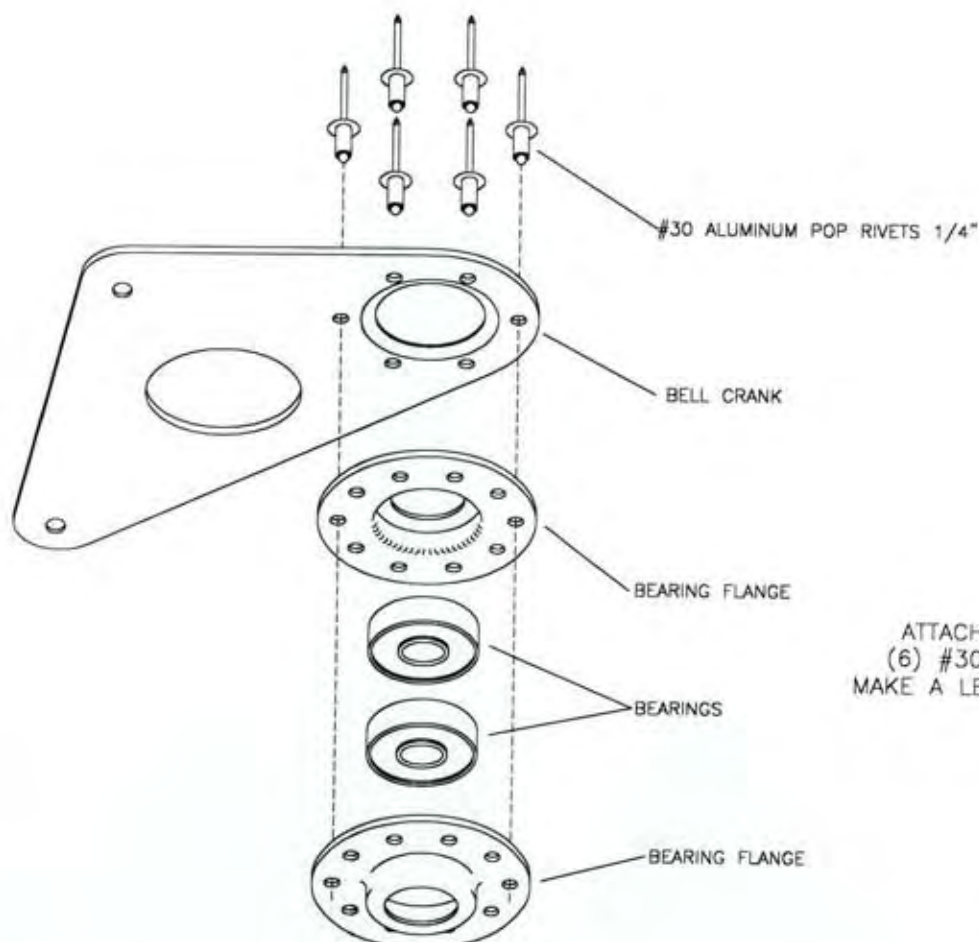


FIGURE 022C-13A

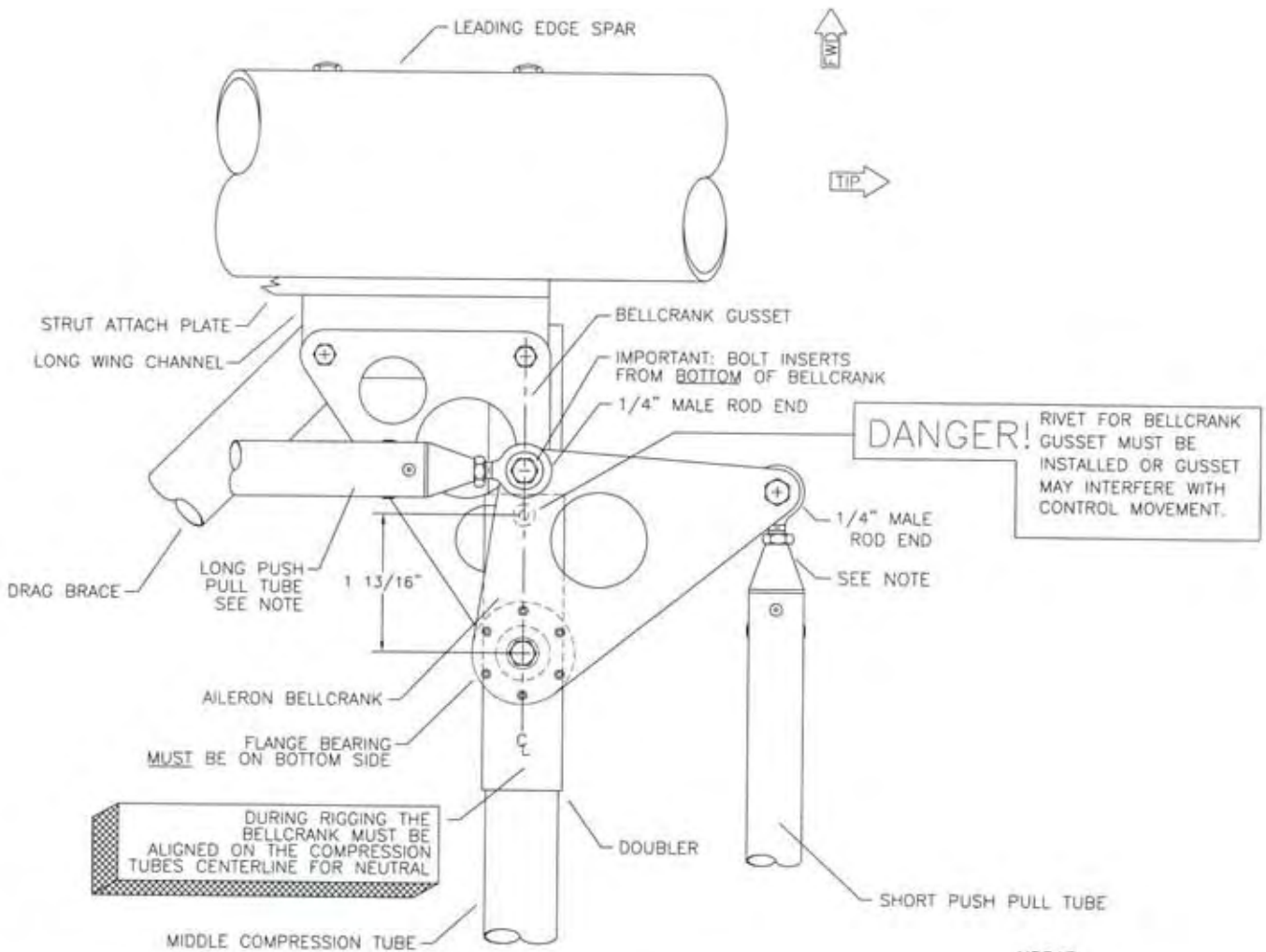


14. Place the bearing flange into the bellcrank hole. **PLEASE NOTE:** Drill out the 3/4" hole to 7/8" and bevel the holes inside edge to allow the bearing flange to fit flat against the bellcrank. Drill and rivet every other hole in the flange bearing for a total of six holes. Pay close attention to which side of the bellcrank the bearing rivets and make one for the left and right. See **Figure 022C-14**. Install the aileron bellcranks as shown in **Figure 022C-14A**. The bellcrank gusset bolts to the channel bracket's two bolts, the other hole is located over the compression tube. Drilling from the bottom, size drill to 1/4" through the compression tube, doubler and gusset. From this 1/4" hole drill a #30 hole 1 13/16" forward towards the channel bracket and rivet the gusset to the tube and doubler using a 1/8" Stainless Steel Rivet. **IMPORTANT:** Install the bellcrank gussets with the small flange pointing **DOWN**. Install the aileron bellcrank with the bearing on the **UNDERSIDE** of the bellcrank. The longer arm of the bellcrank should be to the wing tip side of the compression tube for attachment to the short aileron push pull tube.

FIGURE 022C-14



**FIGURE 022C-14A**



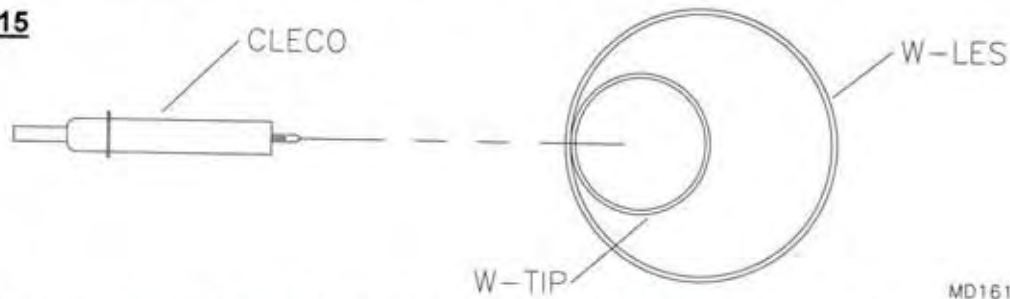
**IMPORTANT:** SMALL FLANGE ON GUSSET MUST POINT DOWN

**CAUTION:** ROD ENDS MUST BE TURNED IN AT LEAST 10 TURNS.

**NOTE:** STOP NUT OR BOTTOM OUT PUSH PULL TUBE ON BELLCRANK DURING FINAL ASSEMBLY. THE ROD END IS LEFT ATTACHED TO THE BELLCRANK. AFTER COVERING THE WING, THE AILERON PUSH PULL TUBE IS INSERTED THROUGH THE EXIT HOLE IN THE WING AND SCREWED INTO THE ROD END.

15. Wing tip bows and spar tips come pre-drilled #11. Cleco tip bow to spars. Inspect fit; tip bow should be tight against both spar. See **Figure 022C-15**. Secure tips to spars with 3/16" stainless steel rivets. Drill a third hole centered between the two holes on front of leading edge spar; install third rivet.

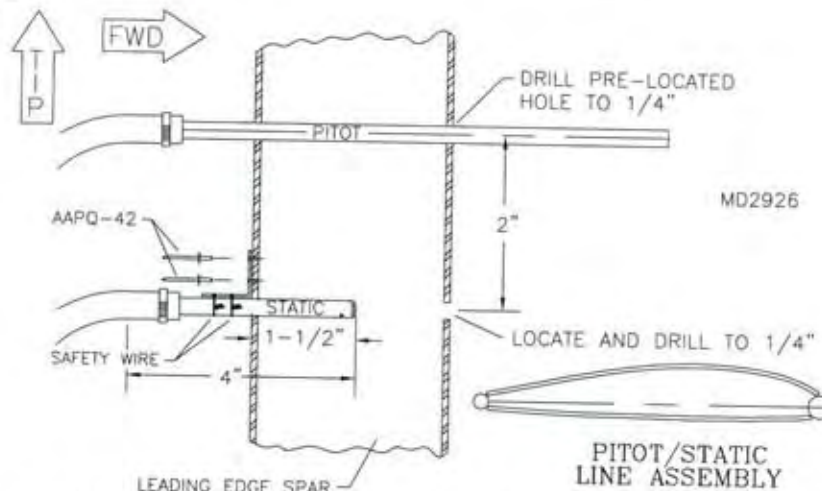
**FIGURE 022C-15**



MD1613

16. Located approximately 7" from the outer end of the left leading edge spar, is a #11 hole. Drill out this hole to 1/4" for the pitot tube. Locate and drill another 1/4" hole 2" inboard from the first for the static tube. From the sealed domed end of the static tube, measure 4" and cut the excess length off. Insert the static tube into the inboard most hole so that it extends into the leading edge spar 1 1/2". Position the aluminum L bracket next to the static tube as shown in **Figure 022C-16**. With a #30 drill bit, transfer drill through the L bracket into the spar and rivet in place. Safety wire the static tube to the L bracket.

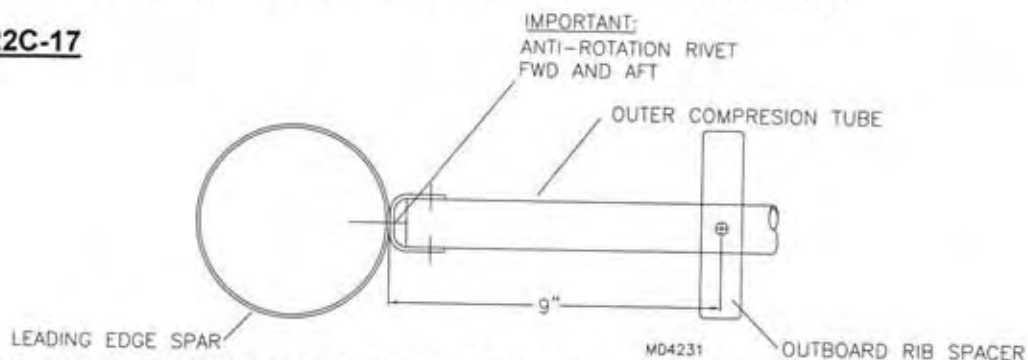
**FIGURE 022C-16**



MD2926

17. Position the outboard rib spacer on the outboard side of the outer compression tube. See **Figure 022C-17** for location. Transfer drill #11 and bolt to the outboard side.

**FIGURE 022C-17**



MD4231

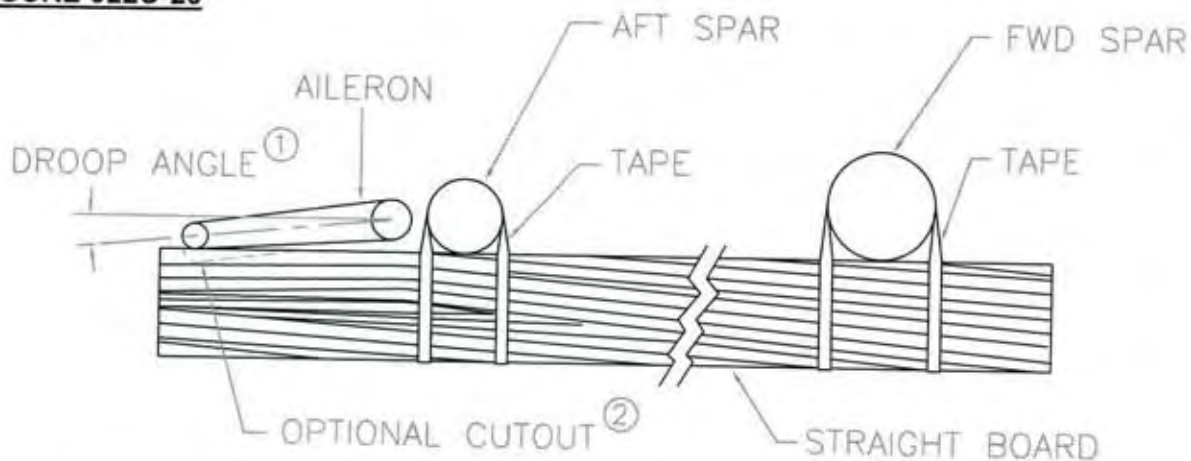
**TURN TO THE FUEL SYSTEM FOR ASSEMBLY DETAILS BEFORE CONTINUING.**

The next section discusses setting up ailerons and flaps. You may want to do this with the wings attached; if so, turn to root rib assembly followed by struts. This will bring you to the point where the wings are on the fuselage, fully set to washout and dihedral.

## RIGGING THE FLAPS AND AILERONS

18. To set up the aileron rigging attach the ailerons and flaps to the wing using the hinges. Put the ailerons and flaps on the side of the hinge that gives the best matched fit. Only finger tighten the nuts to the hinge bolts at this time.
19. Apply a drop of blue Loctite and screw the male rod ends into the ends of the push pull tubes until 1/2" of the thread is exposed. Do not install a stop nut on the bellcrank end of the short push pull tube. The short push pull tube is screwed into the rod ends attached to the bellcrank after covering the wing. Install the aileron push pull tubes using the hardware depicted in the aileron push pull tube parts drawing. **IMPORTANT:** The long push pull tube bolts to the **TOP** of the aileron bellcrank. The short push pull tube bolts to the **BOTTOM**.
20. Before beginning rigging of the ailerons check the control stick and control tee. The control tee must be centered when the sticks are in neutral. If this is not the case review rigging instructions for the control stick and tee under control stick assembly. With the control tee centered adjust the long push pull tubes so the bellcranks are in the neutral position. Refer to **Figure 022C-14A**. Find two very straight boards at least 60" in length. These will be used to set the droop angle of the flaps and ailerons. The droop angle is shown in **Figure 022C-20**. Firmly tape the boards on the bottom of the wing spars. Let the boards overhang off the aft spar at least 8". The aileron trailing edge should rest on the board to set the proper angle of droop. Adjust the rod ends on the short aileron push pull tube until the aileron is set. **IMPORTANT:** The rod ends must be screwed into the ends of the push pull tubes a minimum of 10 full turns to have acceptable strength for flight loads. Remove the boards once both ailerons are set. Test the system by displacing the control stick sided to side. The aileron bellcranks are set up to displace twice as much up as down. You can check this very simply by measuring the difference from the neutral position up and down. If this is not the case it means the bellcrank was not at the neutral point. Refer to **Figure 022C-14A** to check for the neutral bellcrank position. Use blue Loctite to keep the push pull tubes on setting. The short push pull tube will be removed to allow installation of the wing covering. After the wing covers are attached apply a drop of blue Loctite to the end of the forward push pull tube. Screw it into the rod end that was left attached to the aileron bellcrank.

**FIGURE 022C-20**



- ① Drop angle of the aileron and flaps is established when the aileron's trailing edge rests on the board.

PLEASE NOTE: This is the recommended "start" setting. After flight test you may want to droop more for low speed or raise for cruise.

- ② Cut out guide board 1/4" to 3/8" if lower stall speed is desired.

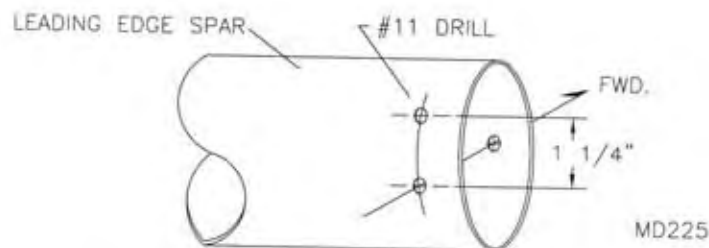
MD316



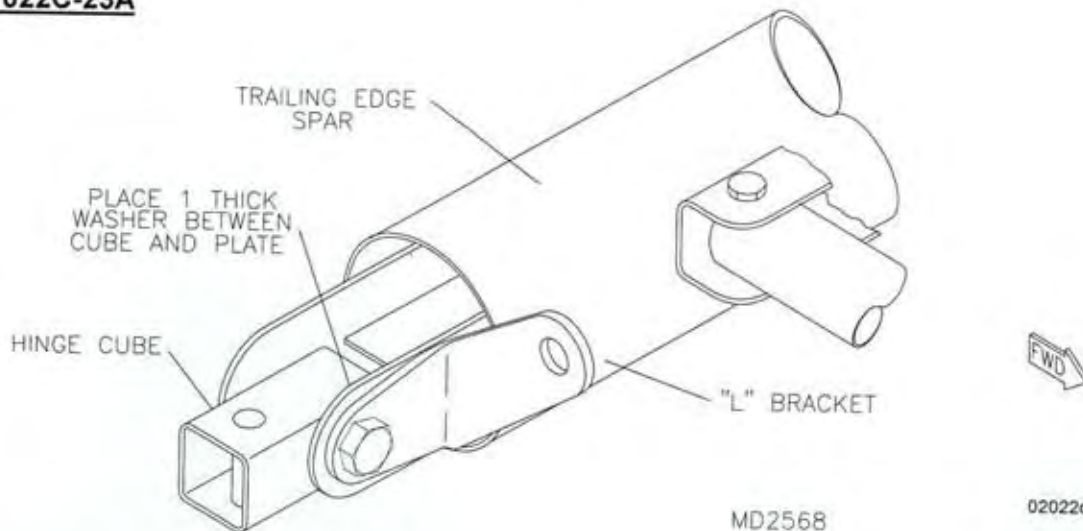
## INSTALLING THE ROOT RIB TENSIONING SYSTEM

21. The wing skin is attached and tensioned span-wise using a prefabricated root rib. The root rib comes ready to install with the exception of the holes for the 8x1/2" PHS. Notice that all the pre-located holes are pre-drilled to a #40. Drill these to a #28 and debur any rough edges. This rib is attached to the wing through two "L" brackets and bolts. These bolts are threaded into the root rib. When the bolts are tightened the root rib moves inboard pulling the wing fabric tight.
22. Collect all the parts depicted in the parts drawing for the root rib.
23. Place the root rib in the wing with the wing skin flush to the inboard side of the root rib. Prepare the leading edge spar as shown in **FIGURE 022C-23**. Bolt the brackets to the leading edge spar and the inboard side of the universal hinge on the trailing edge spar as shown in **FIGURE 022C-23A**. Thread the bolt and washer through the leading edge bracket and root rib into the hole provided. Install the nut and washer on the inside of the root rib. **NOTE: Do not tighten the bolts at this point.** Position the root rib against the brackets. Transfer drill 1/4" through the trailing edge bracket and root rib. Thread the bolt and washer through the trailing edge bracket and root rib. Install the nut and washer on the inside of the root rib. **NOTE: Do not tighten the bolts at this point.** Line up the wing skin and Velcro so they are properly centered on the trailing edge spar and the entire wing. **NOTE: See the covering section for details.** Install the 8x1/2" PHS through the wing skin and pre-drilled holes in the root rib. Use an icepick or a small awl to transfer the predrilled holes from the root rib through the wing skin edge webbing. Start installing the 8x1/2" PHS screws in the center of the root rib, working to the end of the rib. The root rib is curved inboard to assure the rib will be straight when installation is complete. Flip the wing and repeat on the bottom side. When screws are installed, begin to tension bolts. Tighten to 3/8" from the inside edge of the "L" brackets. **Caution: Do not over-tighten the tensioning bolts. Stop when the skin is tight, if within 3/8" of the bracket.**

**FIGURE 022C-23**



**FIGURE 022C-23A**



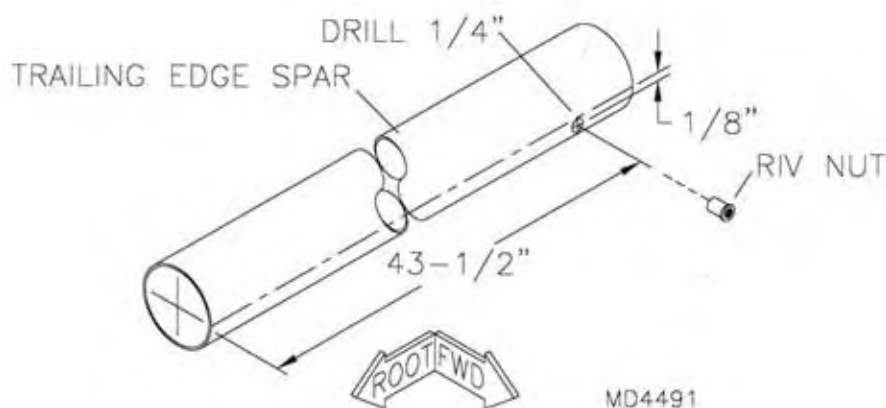
## INSTALLING THE ROOT RIB SKIN

24. Position the root rib skin against the root rib assembly. **NOTE:** Align the notches in the root rib skin with the rivets retaining the root rib channels. Transfer drill #30 the skin and rib. Cleco as you drill.
25. Install the rubber grommets. These protect the fuel sight gauge tubing. During final assembly install the sight gauge, fuel level decals and rivet the root rib skin to the root rib.
26. Apply an anti-chafe material to the aft end of the root rib skin as required.

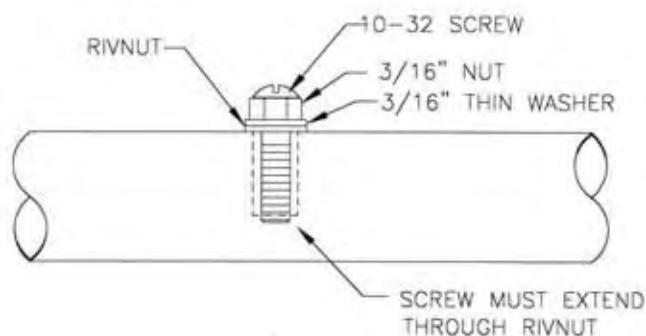
## PREPARING WING FOR AFT JURY STRUT

27. Locate and drill a 1/4" hole in the forward side of each Trailing Edge Spar per **FIGURE 022C-27**. Install the 1/4" riv-nut using the procedure shown in **FIGURE 022C-27A**. The Aft Jury Strut will bolt to the spar using this riv-nut during final assembly.

**FIGURE 022C-27**



**FIGURE 022C-27A**



PROCEDURE:

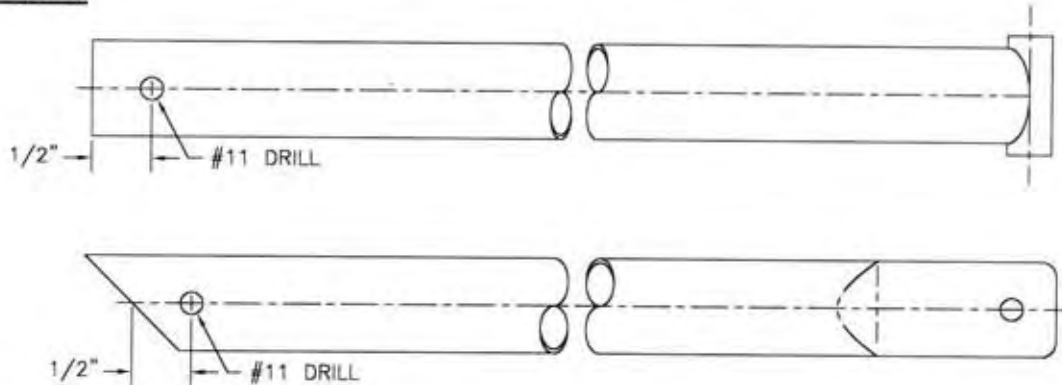
1. FINGER TIGHTEN NUT AND RIVNUT ONTO SCREW.
2. INSERT RIVNUT INTO 1/4" HOLE.
3. TURN NUT THREE TURNS CLOCKWISE WHILE HOLDING SCREW STATIONARY.
4. BACK NUT OFF HALF A TURN AND REMOVE SCREW.

MD343

## S-6ES COYOTE II STANDARD WING - JURY STRUT ASSEMBLY

1. Collect the parts called out in the parts list for the jury strut. It is assumed the aircraft is assembled with the wings and struts on.
2. Install the eyebolts in the Lift Struts. **CAUTION:** Do **NOT** crush the lift struts by over-tightening the eyebolts.
3. Bolt the Jury Strut Connect Tube to the eyebolts. **NOTE:** The straight vertical tab indicates the forward end. Apply masking tape to the inboard edge of each tab. Mark the tab's centerline.
4. Drill a #11 hole per **Figure 022D-04** in the lower end of the Fwd and Aft Jury Struts. Slip the lower end of the Forward Jury Strut over the fwd tab. Bolt the top end to the Jury Strut Attach Bracket. Align the hole in the jury strut with the tab centerline. Transfer drill #11. **NOTE:** You may want to mark the hole location on the tab with the #11 bit and drill in a drill press. **CAUTION:** Be sure the lift strut is straight before drilling. Trim the lower end of the Fwd Jury Strut if required. Insert a bolt to temporarily hold in place.

**FIGURE 022D-04**



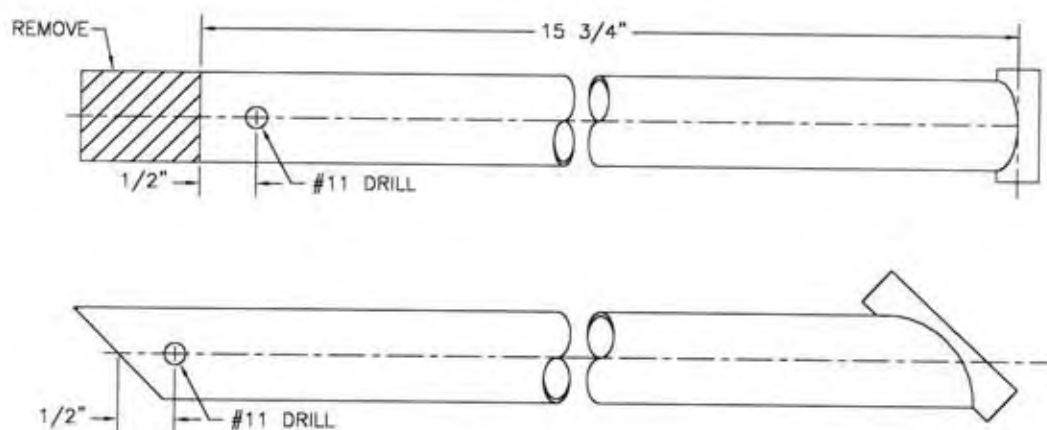
MD4468

5. Slip the lower end of the Aft Jury Strut over the aft tab. Temporarily bolt the top end to the Flap Compression Tube (W-FCT), 1 1/2" aft of the Flap Retainer Bracket. Align the hole in the jury strut with the tab centerline. Transfer drill #11. **NOTE:** You may want to mark the hole location on the tab with the #11 bit and drill in a drill press. **CAUTION:** Be sure the lift struts are straight before drilling. Trim the lower end of the Fwd Jury Strut if required. Insert a bolt to temporarily hold in place.
6. Remove the Forward and Aft Jury Struts. Be sure to mark left and right. Trim the Plastic Shims to match the tabs on the Jury Strut Connect Tubes. Trim two (2) shims per tab. Align the Plastic Shims on each tab, mark and drill #11.
7. Paint or powdercoat the jury struts as desired. Reinstall the Forward and Aft Jury Struts with the Plastic Shims during final assembly. Tapering of the shim will be required for proper fit. Safety wire the drilled head bolts.

## S-6ES COYOTE II 116 WING - JURY STRUT ASSEMBLY

1. Collect the parts called out in the parts list for the jury strut. It is assumed the aircraft is assembled with the wings and struts on.
2. Install the eyebolts in the Lift Struts. **CAUTION:** Do **NOT** crush the lift struts by over-tightening the eyebolts.
3. Bolt the Jury Strut Connect Tube to the eyebolts. **NOTE:** The straight vertical tab indicates the forward end. Apply masking tape to the inboard edge of each tab. Mark the tab's centerline.
4. Trim the Fwd Jury Strut per **Figure 022D-04**. Slip the lower end of the Forward Jury Strut over the fwd tab. Temporarily bolt the top end to the Jury Strut Attach Bracket. Trim the lower end of the Fwd Jury Strut if required. Drill a #11 hole per **Figure 022D-04** in the lower end of the Fwd and Aft Jury Struts. Align the hole in the jury strut with the tab centerline. Transfer drill #11. **NOTE:** You may want to mark the hole location on the tab with the #11 bit and drill in a drill press. **CAUTION:** Be sure the lift strut is straight before drilling. Insert a bolt to temporarily hold in place.

**FIGURE 022D-04**



MD4469

5. Slip the lower end of the Aft Jury Strut over the aft tab. Temporarily bolt the top end to the Riv-nut in the Trailing Edge Spar. Align the hole in the jury strut with the tab centerline. Transfer drill #11. **NOTE:** You may want to mark the hole location on the tab with the #11 bit and drill in a drill press. **CAUTION:** Be sure the lift struts are straight before drilling. Trim the lower end of the Aft Jury Strut if required. Insert a bolt to temporarily hold in place.
6. Remove the Forward and Aft Jury Struts. Be sure to mark left and right. Trim the Plastic Shims to match the tabs on the Jury Strut Connect Tubes. Trim two (2) shims per tab. Align the Plastic Shims on each tab, mark and drill #11.
7. Paint or powdercoat the jury struts as desired. Reinstall the Forward and Aft Jury Struts with the Plastic Shims during final assembly. Tapering of the shim will be required for proper fit. Safety wire the drilled head bolts.

## AIRCRAFT COVERING SAFETY TIPS FOR DACRON SKINS

Safety is a personal responsibility. You, as the owner, operator, and chief pilot, are responsible for the airworthiness of your aircraft. Ultimately, you control the life and monitor the level of safety through pre-flight inspections. During pre-flight check for the following:

- A.) Fabric rot
- B.) Thread wear and broken stitches. (Open ends lead to premature seam separation.)
- C.) Chafing and hanger rash
- D.) Fading

Watch you fabric for signs of fading. The number one sign of ultraviolet damage is a lightening in the color of the fabric. The Dacron used to cover your aircraft was originally designed for sailboats. Sailors typically stow away their sails after a hard days sailing. Extend your fabric life by using a field storage cover or a hangar.

Life expectancy varies with latitude. The closer to the equator you are, the more intense UV rays get. Also, there are indications that due to environmental factors, like ozone depletion, the amount of solar radiation penetrating the atmosphere is increasing. A conservative estimate on the life span of untreated 3.9 Dacron is 350 exposure hours. Controlled exposure can extend life of untreated sailcloth to 10 years.

Coatings can help extend useful life. Clear Imron can double the life of a covering. The disadvantage of this type of process is that the skins become a permanent part of the aircraft. Should a skin need removing for repairs, etc. the coatings may crack and peel giving you a molting snake effect.

As mentioned earlier, storage methods can increase life. Tarps and fitted covers are recommended for outside storage. If available, shade hangers are better and fully enclosed hangers are best.

Extend the life of good fabric by making repairs.

- A.) Check for growth of minor rash and pin holes.
- B.) For small cuts or holes 2" or less, sew with a baseball stitch, then apply sail tape or a glue patch.
- C.) Medium sized cuts or holes 2" to 6" can be repaired by applying an adhesive patch and hand stitching.
- D.) Large rips and holes and/or blown out panels 6" or larger should be examined by a professional repair service.

### TESTING FABRIC

- A.) **FADE FACTOR:** Compare the top and bottom surfaces of your wing. Top surfaces of a considerably lighter shade are a cause for concern.
- B.) **FINGER POKE TEST:** Poke the top surface of your wing. A finger poke will not go through good fabric.
- C.) **FABRIC TESTER:** This involves standardized testing with a calibrated scale.  
**MAX:** The maximum value for new fabric is 25#.  
**MIN:** The minimum safe values are 12# or 15# depending on surface tested.

When in doubt, throw it out! Live to fly again tomorrow!

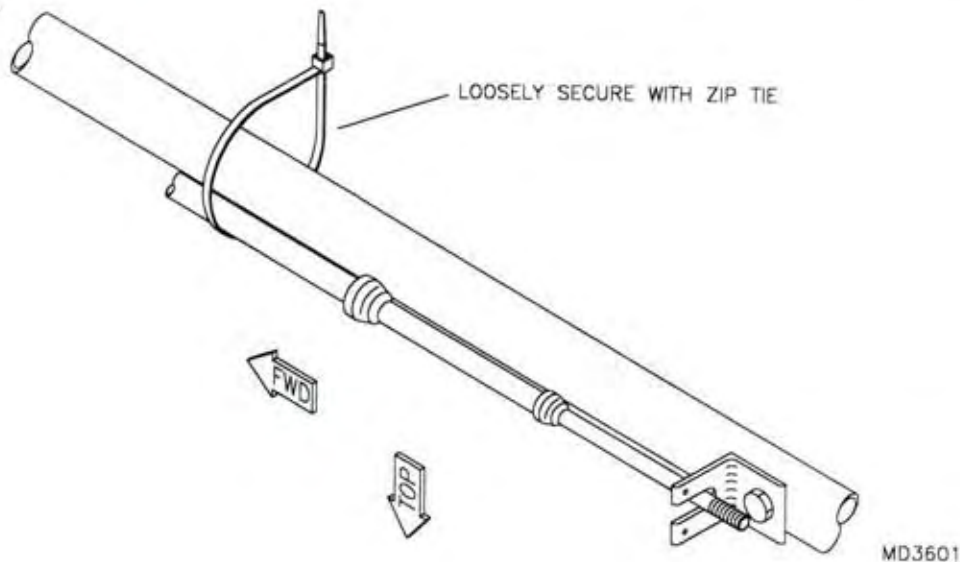
## S-6ES COYOTE II COVERING - STD. WING

**NOTE:** If you are covering a 116 Wing, refer to the next section.

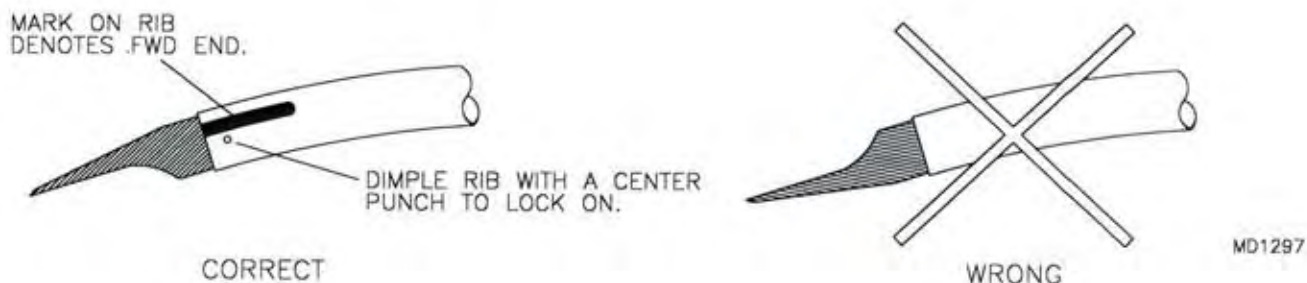
The wings should be removed from the fuselage for covering. Set the wings on sawhorses that are about 30" to 32" high. This makes the job less of a back bending effort! The wings should be complete including the root rib installation.

1. Do **NOT** remove the flap Teleflex from the inside of the wing. Use a zip tie to loosely retain the Flap Teleflex Cable to the compression tube prior to covering. See **Figure 023-01**. Attach the cable to the retainer and safety wire in final assembly. An access zipper is located near the Flap Teleflex exit. Use this access to place the Teleflex in the retainer after covering.

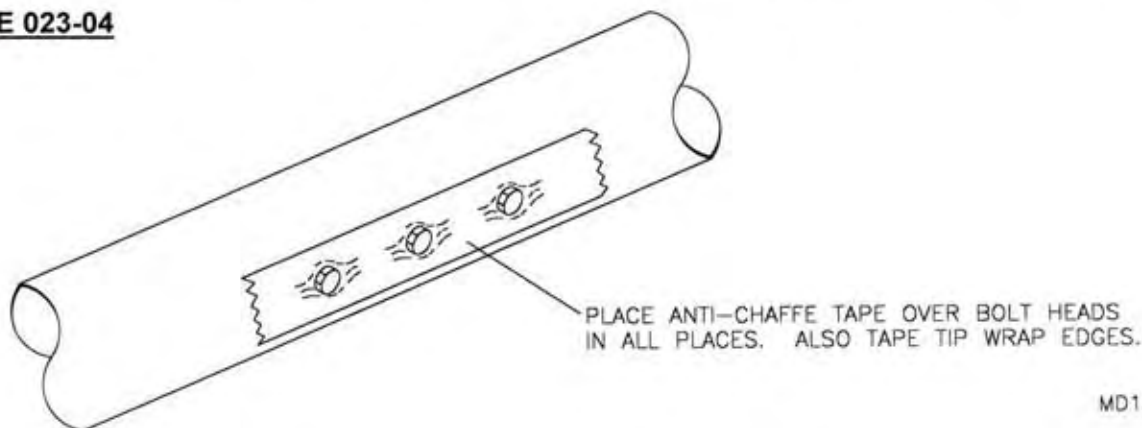
**FIGURE 023-01**



2. Route the plastic tubing (fuel line) to the pitot/static tubes and secure with a fuel line clamp. The lines should run on **TOP** of the internal bracing tubes, over the **TOP** of the root compression tube with approximately 1 foot of line into the cabin. Route the pitot/static lines out of the Airspeed Indicator to the appropriate tubes. Run the lines from the panel down the left hand side between the rope lacing, behind the S-3, and come out at the top and connect to each line from the wing with a 2" long 1/4" aluminum tube. These will be used to disconnect the lines when removing for storage. The lines should exit the wing as far **AFT** as possible; this will allow the lines to stay connected for folding. The short aileron push pull tubes should be removed, leaving the rod end attached to the bellcrank. Be sure to use a jam nut on the rod end for the short push pull tube. If you have not already done so, Loctite the jam nut on the long push pull tube at the bellcrank. After the wing is covered and the short push pull tube opening is cut into the wing, we will Loctite the end of the short push pull tube and screw it to the bellcrank.
3. Assemble the top and bottom ribs by installing the rib tips. Install the duckbill shaped rib tips into the forward end of the top ribs and both ends of the bottom ribs. Note that the mark on one end of the bottom rib denotes the forward end of the rib. Dimple the ribs with a center punch to secure the tip fittings. Clean the mark off before insertion. See **Figure 023-03**.

**FIGURE 023-03**

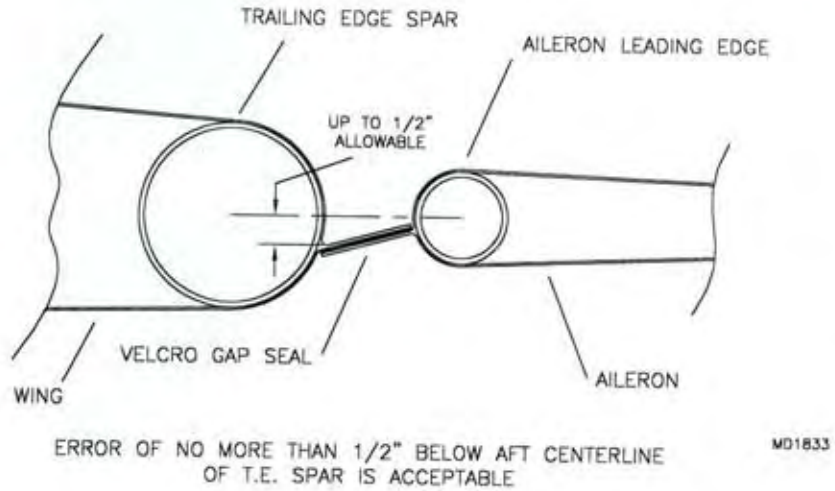
4. Tape over all bolt heads with a good grade of anti-chafe tape. See **Figure 023-04**. This will make it easier to slip on the wing covers. Before skinning the wing, please inspect for completion and proper assembly using the following check list. Please note some items will apply to other models.

**FIGURE 023-04**

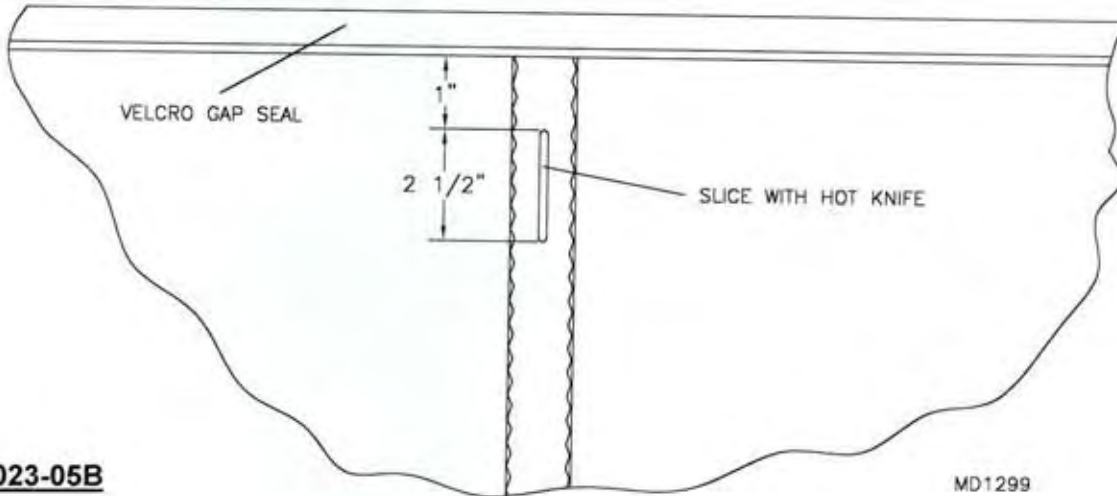
- A. Are the pitot lines, static lines and probes installed? These will be poked through the leading edge after skinning by reaching inside the wing through a zipper. It is only required that the probes are inserted into the spars but not through them.
- B. Is the Teleflex cable for the flaps installed? **IMPORTANT:** Do not tie wrap the Teleflex cables to the wing tubes. These must be allowed to lay loose inside the wing for best operation. It also makes for replacement easier.
- C. Are all the bolts properly installed with the nuts tight?
- D. Inspect all rivets, fittings, and nut plates. Make sure all hinge point nut plates are installed.
- E. Insert the push pull tubes for proper installation. The rod end for the bellcrank to the aileron push pull tube must be installed before covering. It is best to have set up the wings minus the skins, and rig the flaps and ailerons.

5. Remove the wing cover (LH or RH) from the box and lay it on top of the wing frame, bottom side up, leading edge forward and the root end at the tip. Pull the open end over the frame. Have a helper feed it over the end while you pull it on. Go slowly. Do **NOT** force it!! Stop pulling about 12" from the root rib. The trailing edge Velcro gap seal should line up on centerline of the trailing edge spar. Up to 1/2" below centerline is acceptable. See **Figure 023-05**. With the wing upside down, slit the first rib pocket on the bottom from the root as per **Figure 023-05A** and install a top rib. Now pull the skin on the frame as far as possible. Back out the 1/4" bolts that retain the root rib so the skin will reach the root end of the root rib. **Hint:** Fabricate temporary tensioning bolts. See **Figure 023-05B**.

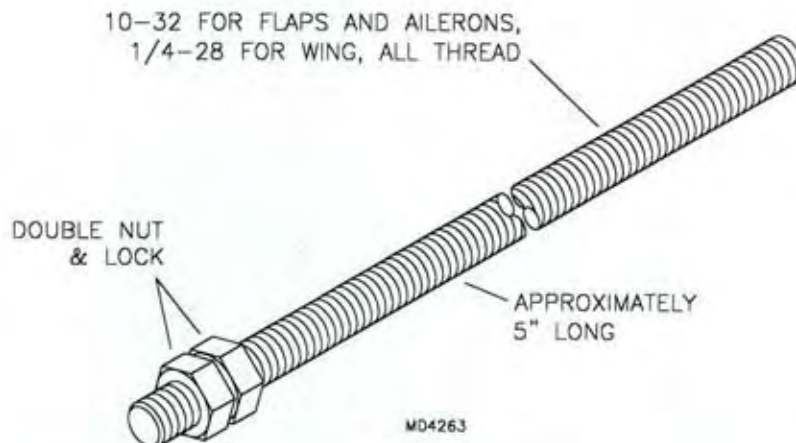
**FIGURE 023-05**



**FIGURE 023-05A**

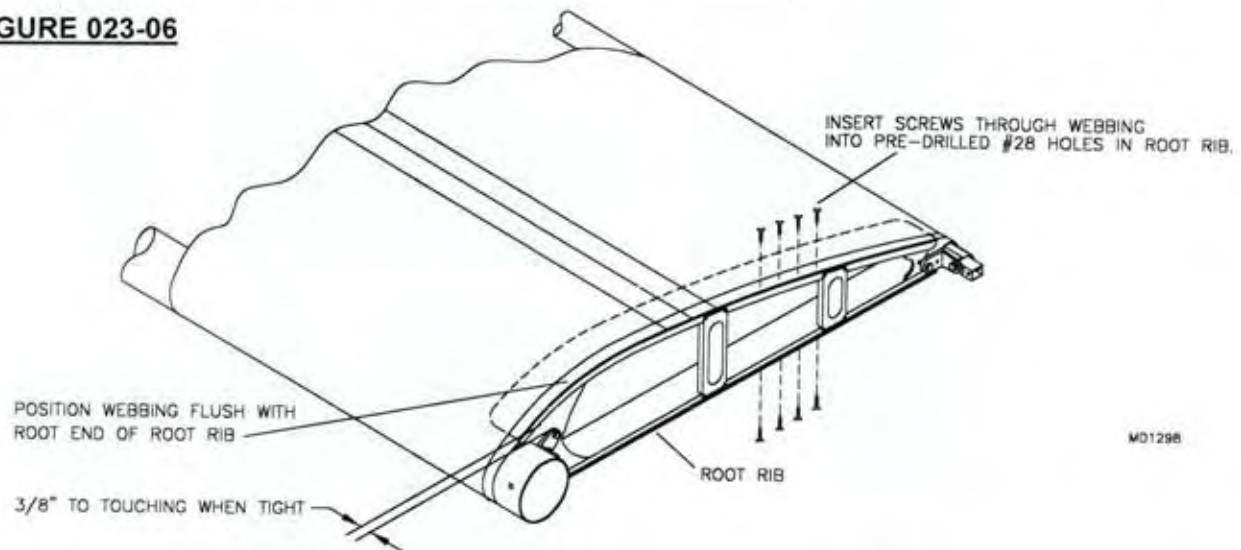


**FIGURE 023-05B**





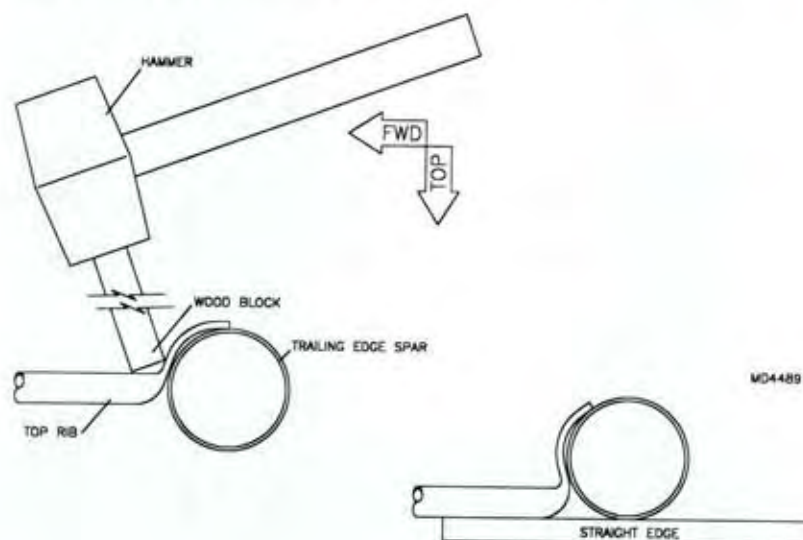
6. Secure the skin to the root rib by installing the proper screws through the webbing of the skin into the pre-drilled holes in the root rib. See **Figure 023-06**. Tension the skin by evenly tightening the two 1/4" tensioning bolts until the root rib is from within 3/8" to touching the "L" brackets.

**FIGURE 023-06**

7. With the wing upside down, cut a slit for each rib pocket. **NOTE:** Only cut on the bottom surface of the wing. Refer back to **Figure 023-05A**.

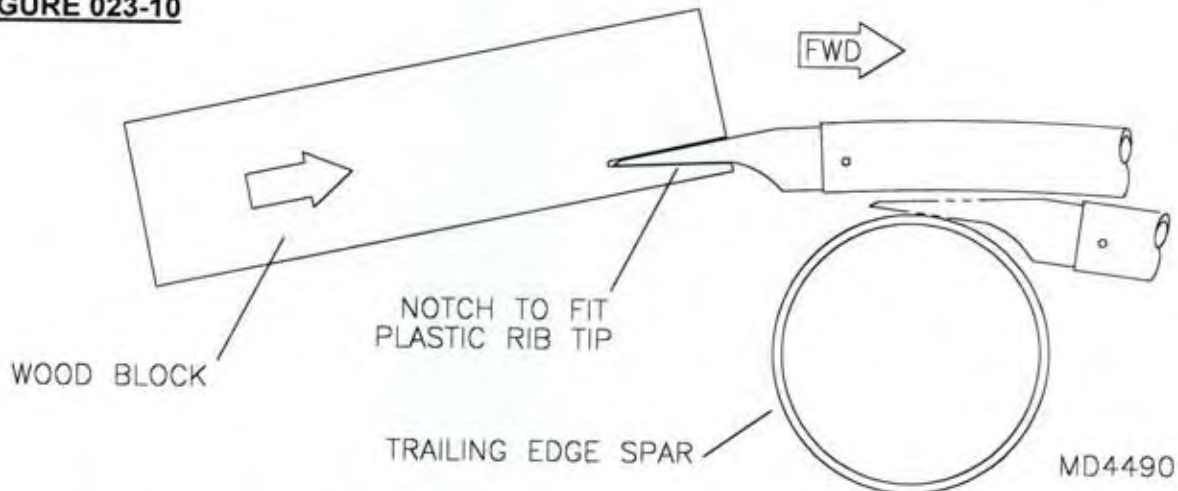
8. With the wing upside down, install the top ribs through the slits made in the bottom pockets. **IMPORTANT:** Be sure the ribs insert into the sewn pockets. **NOTE:** They should push in with a good degree of pressure. Use a small mallet and gently tap in place. A short scrap of lumber works as an excellent driving ram. That sound you are hearing is not the stitches ripping, but the 2-way tape popping loose. This is perfectly normal and does not affect the strength of the skins. The ribs do drive in hard, but be careful of the last one near the wing tip. It may try to jam under the tip wrap. If it does, push the fabric from the bottom at the leading edge to help it line up. **PLEASE NOTE:** In some places rivets or nut plates may hang up the aft curve of the rib. Simply move the rib to either side to clear.

9. The aft end of the top ribs must be rotated into place against the aft spar. Using a small block of wood and a hammer, push the rib aft and toward the top skin. See **Figure 023-09**. This will rotate the top of the rib inline with the aft spar and allow the bottom rib to set against the spar.

**FIGURE 023-09**

10. Install the bottom ribs the same way, except to get them started insert the rib upside down, this will help the tip slide into the pocket, then turn it right side up (tip curve down). Push the rib into place. **HINT: Make a push block from wood.** See **Figure 023-10**. The bottom rib tip will lie against the bottom of the trailing edge spar sealing shut the slit made for rib insertion. Top rib removal is done by making a tool from an old screwdriver. Heat and bend the end into a 90 degree hook. Use the tool to reach up inside the slit to grab a rib and pull it out. Always remove the bottom rib first.

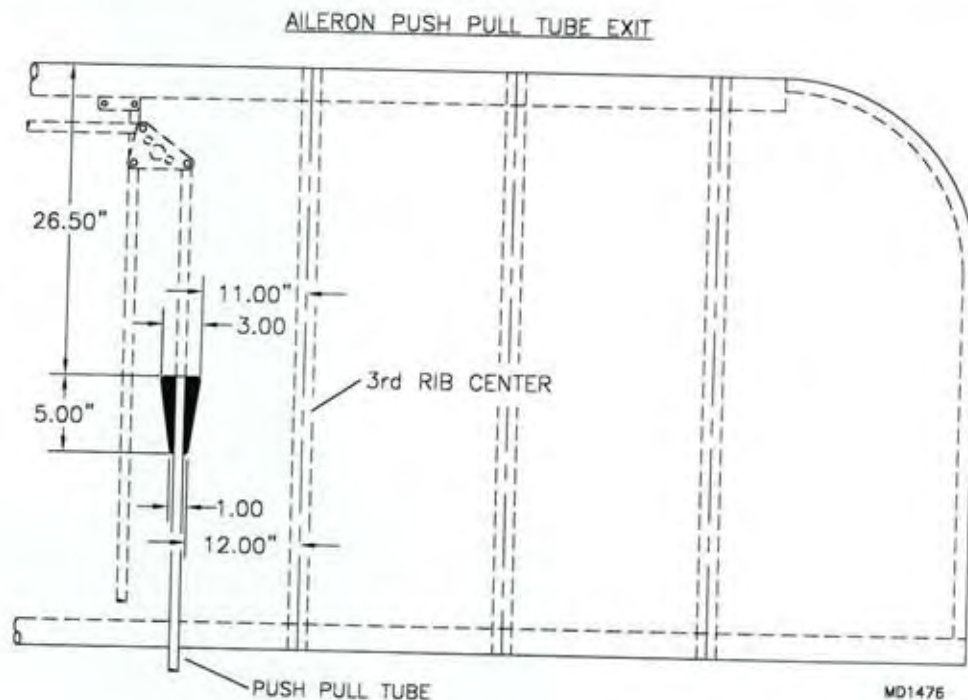
**FIGURE 023-10**

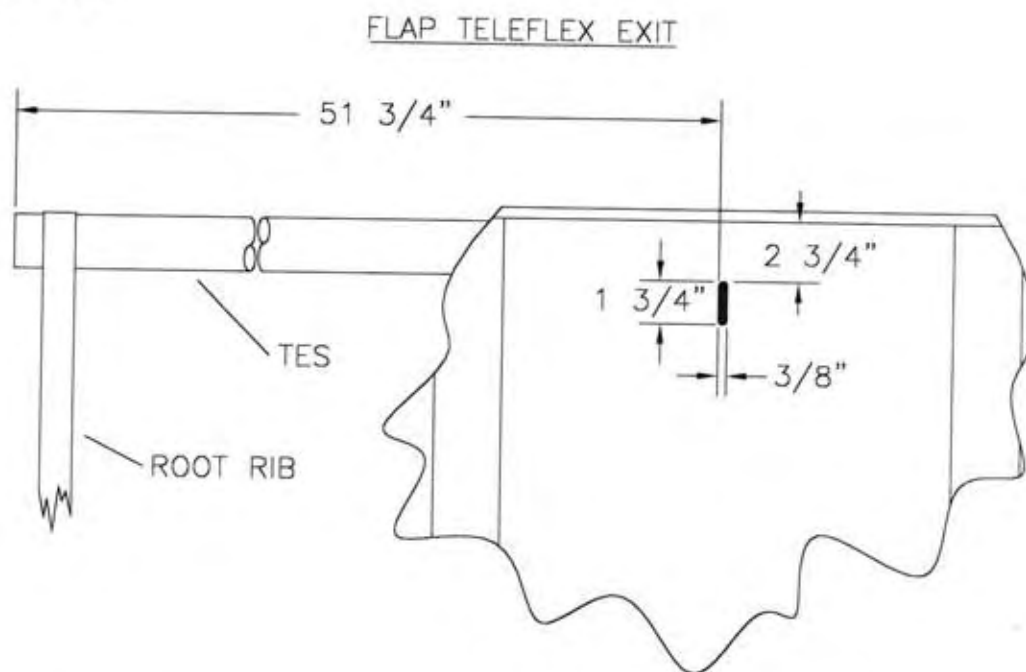
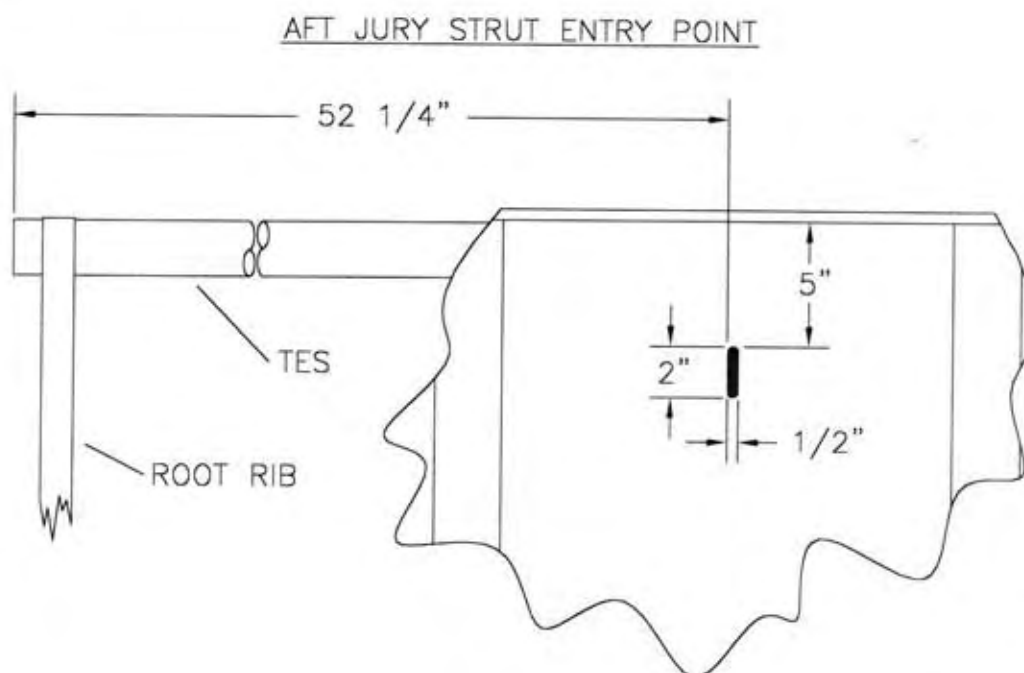


11. Smooth out any wrinkles or fold lines in the wing skins with a household electric iron. Be careful not to melt the skins. 350 degrees is the maximum temperature used. After 350 degrees the cloth will stop shrinking and start stretching. A hot air gun or model airplane heat gun used for shrinking mono-coat works great for the stubborn areas. **CAUTION: Be very careful!! Hot air guns create very high temperatures and can melt through Dacron very easily and very quickly.** **HINT: Angle the hot air gun to blow across the skin rather than directly at it and keep the nozzle moving.**

12. Make cut outs around the fuel tank filler, strut attach plates and jury strut tabs by following around the protrusion with a hot knife. Re-shrink the surrounding skin as needed. Locate and cut holes for the flap and aileron exits as shown in **Figure 023-12** and **Figure 023-12A**. Locate and cut the hole for the Aft Jury Strut exit as shown in **Figure 023-12B**. Cut open each zipper. **NOTE: If applying clear-coat, cut the exit holes and zippers after clear-coat is dry.**

**FIGURE 023-12**

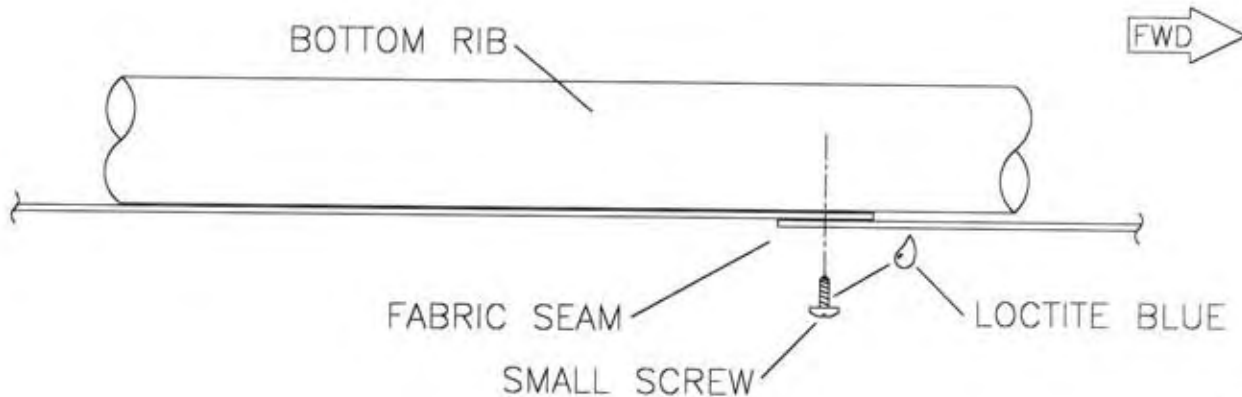


**FIGURE 023-12A****FIGURE 023-12B**

13. Melt holes for the static and pitot tubes. Push them out by reaching inside through the zippers. Poke holes with the hot knife for the aileron and flap hinge bolts. Cut away the Velcro gap seals the same as it was done on the flaps and ailerons.

14. If clear-coat will **NOT** be applied to the wing, then to prevent the bottom rib from sliding out, it is required to install a small screw. Locate this screw through the bottom fabric on a seam where the fabric is doubled, such as one of the stripes. Drill a #40 hole through the fabric and rib. Place a small amount of Loctite on the screw and install. See **Figure 023-14**.

**FIGURE 023-14**



MD1296

15. After attaching wings to the fuselage the bottom root gap seals may be installed. The bottom root gap seals are two sheet metal covers that fill the gap between the wing and fuselage on the wings underside. They must be fitted to the wing after the wings are attached. Look closely at the gap seals. You will notice there is a left and a right seal. The flange on the gap seals narrows to the AFT. **IMPORTANT:** To avoid hitting the screws that retain the wing covering apply a strip of masking tape along the bottom webbing. Mark on the tape where the screws occur. Apply a strip of foam rubber to the small flange. Hold the gap seal in position and mark for five screw locations. Locate the end screws about 3/4" inside of the root rib. Place as near the center as possible. Locate the last two screws half way between the center and the ends. Drill through the gap seal and into the root rib with a #30 bit. Install #6 pan head screws.

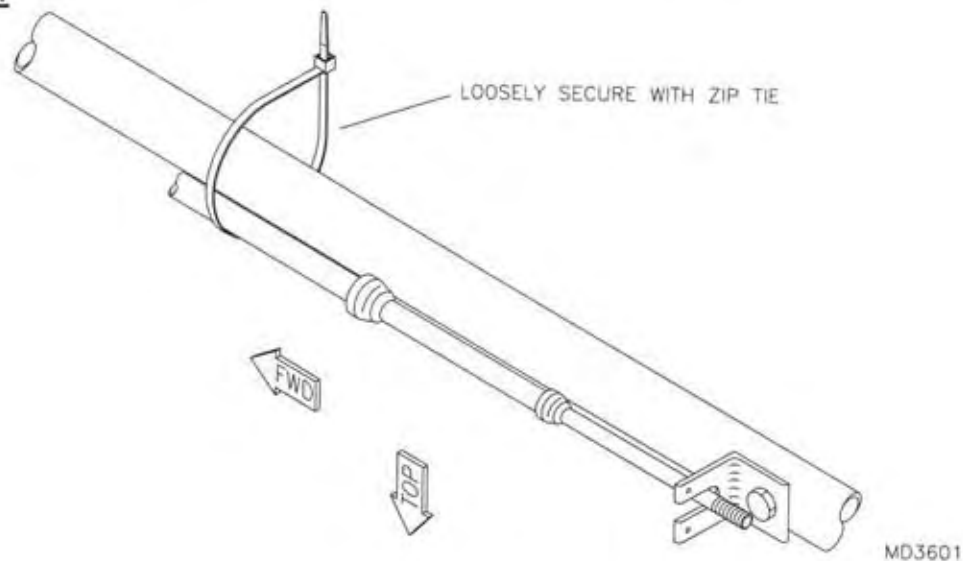
## S-6ES COYOTE II COVERING - 116 WING

**NOTE:** If you are covering a Standard Wing, refer to the previous section.

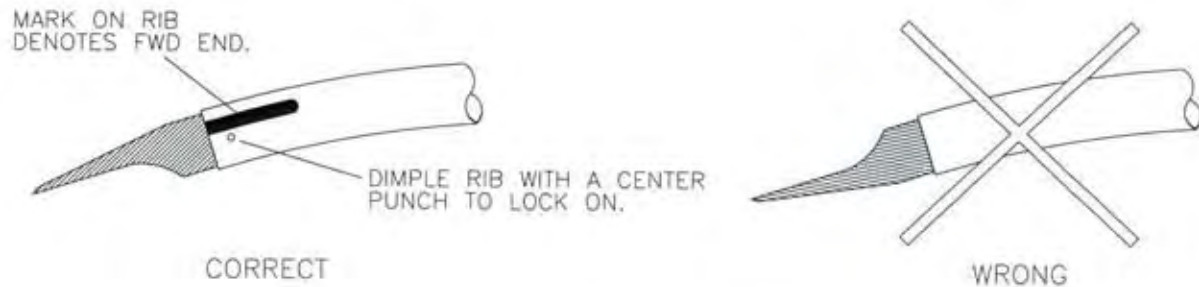
The wings should be removed from the fuselage for covering. Set the wings on sawhorses that are about 30" to 32" high. This makes the job less of a back bending effort! The wings should be complete including the root rib installation.

1. Do **NOT** remove the flap Teleflex from the inside of the wing. Use a zip tie to loosely retain the Flap Teleflex Cable to the compression tube prior to covering. See **Figure 023A-01**. Attach the cable to the retainer and safety wire in final assembly. An access zipper is located near the Flap Teleflex exit. Use this access to place the Teleflex in the retainer after covering.

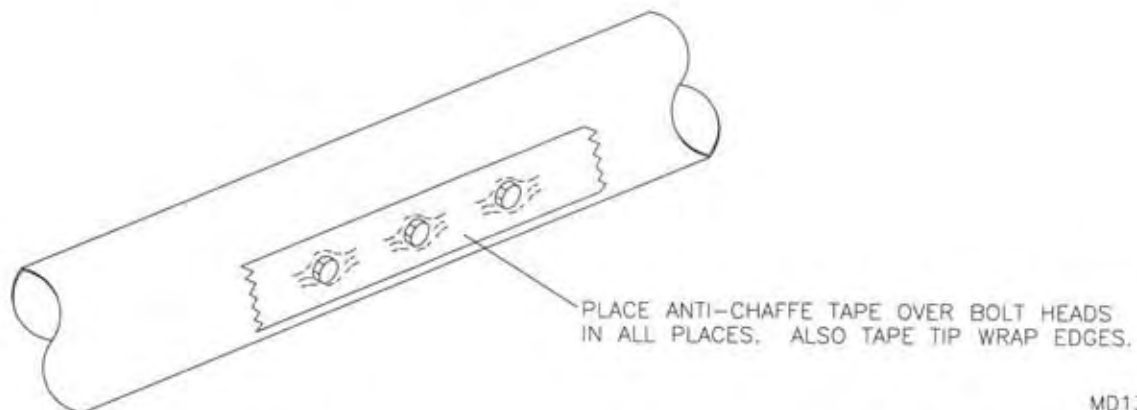
**FIGURE 023A-01**



2. Route the plastic tubing (fuel line) to the pitot/static tubes and secure with a fuel line clamp. The lines should run on **TOP** of the internal bracing tubes, over the **TOP** of the root compression tube with approximately 1 foot of line into the cabin. Route the pitot/static lines out of the Airspeed Indicator to the appropriate tubes. Run the lines from the panel down the left hand side between the rope lacing, behind the S-3, and come out at the top and connect to each line from the wing with a 2" long 1/4" aluminum tube. These will be used to disconnect the lines when removing for storage. The lines should exit the wing as far **AFT** as possible; this will allow the lines to stay connected for folding. The short aileron push pull tubes should be removed, leaving the rod end attached to the bellcrank. Be sure to use a jam nut on the rod end for the short push pull tube. If you have not already done so, Loctite the jam nut on the long push pull tube at the bellcrank. After the wing is covered and the short push pull tube opening is cut into the wing, we will Loctite the end of the short push pull tube and screw it to the bellcrank.
3. Assemble the top and bottom ribs by installing the rib tips. Install the duckbill shaped rib tips into the forward end of the top ribs and both ends of the bottom ribs. Note that the mark on one end of the bottom rib denotes the forward end of the rib. Dimple the ribs with a center punch to secure the tip fittings. Clean the mark off before insertion. See **Figure 023A-03**.

**FIGURE 023A-03**

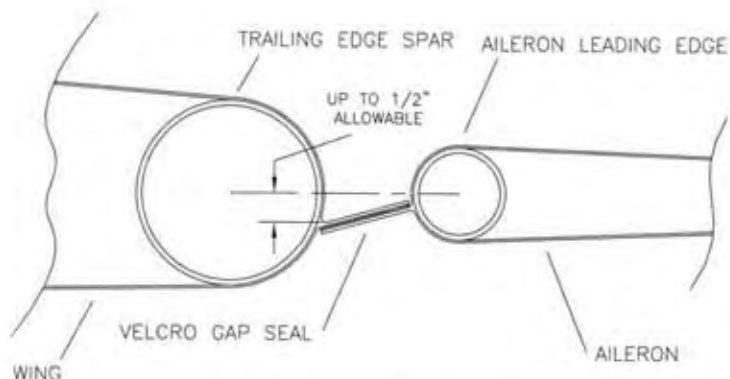
4. Tape over all bolt heads with a good grade of anti-chafe tape. See **Figure 023A-04**. This will make it easier to slip on the wing covers. Before skinning the wing, please inspect for completion and proper assembly using the following check list. Please note some items will apply to other models.

**FIGURE 023A-04**

- A. Are the pitot lines, static lines and probes installed? The pitot tube will be poked through the leading edge after skinning by reaching inside the wing through a zipper. It is only required that the pitot tube is inserted into the spar, but not through it.
- B. Is the Teleflex cable for the flaps installed? **IMPORTANT:** Do not tie wrap the Teleflex cables to the wing tubes. These must be allowed to lay loose inside the wing for best operation. It also makes for replacement easier.
- C. Are all the bolts properly installed with the nuts tight?
- D. Inspect all rivets, fittings, and nut plates. Make sure all hinge point nut plates are installed.
- E. Insert the push pull tubes for proper installation. The rod end for the bellcrank to the aileron push pull tube must be installed before covering. It is best to have set up the wings minus the skins, and rig the flaps and ailerons.

5. Remove the wing cover (LH or RH) from the box and lay it on top of the wing frame, bottom side up, leading edge forward and the root end at the tip. Pull the open end over the frame. Have a helper feed it over the end while you pull it on. Go slowly. Do **NOT** force it!! Stop pulling about 12" from the root rib. The trailing edge Velcro gap seal should line up on centerline of the trailing edge spar. Up to 1/2" below centerline is acceptable. See **Figure 023A-05**. With the wing upside down, slit the first rib pocket on the bottom from the root as per **Figure 023A-05A** and install a top rib. Now pull the skin on the frame as far as possible. Back out the 1/4" bolts that retain the root rib so the skin will reach the root end of the root rib. **Hint: Fabricate temporary tensioning bolts.** See **Figure 023A-05B**.

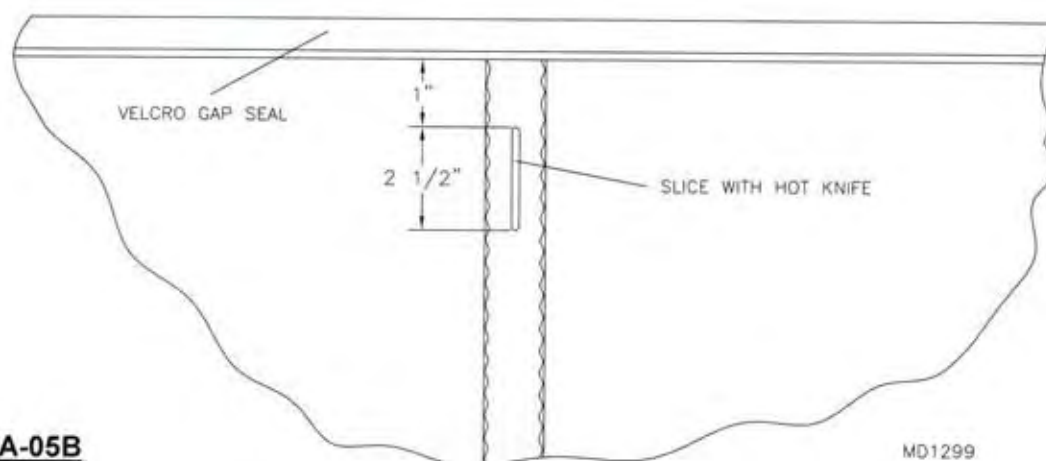
**FIGURE 023A-05**



ERROR OF NO MORE THAN 1/2" BELOW AFT CENTERLINE OF T.E. SPAR IS ACCEPTABLE

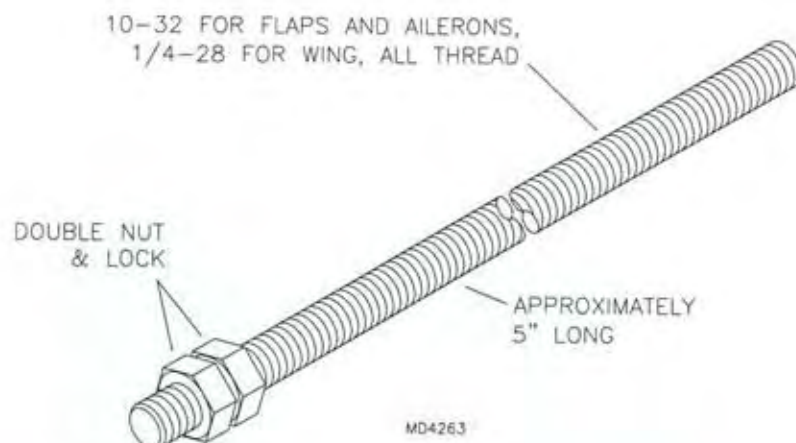
MD1833

**FIGURE 023A-05A**



MD1299

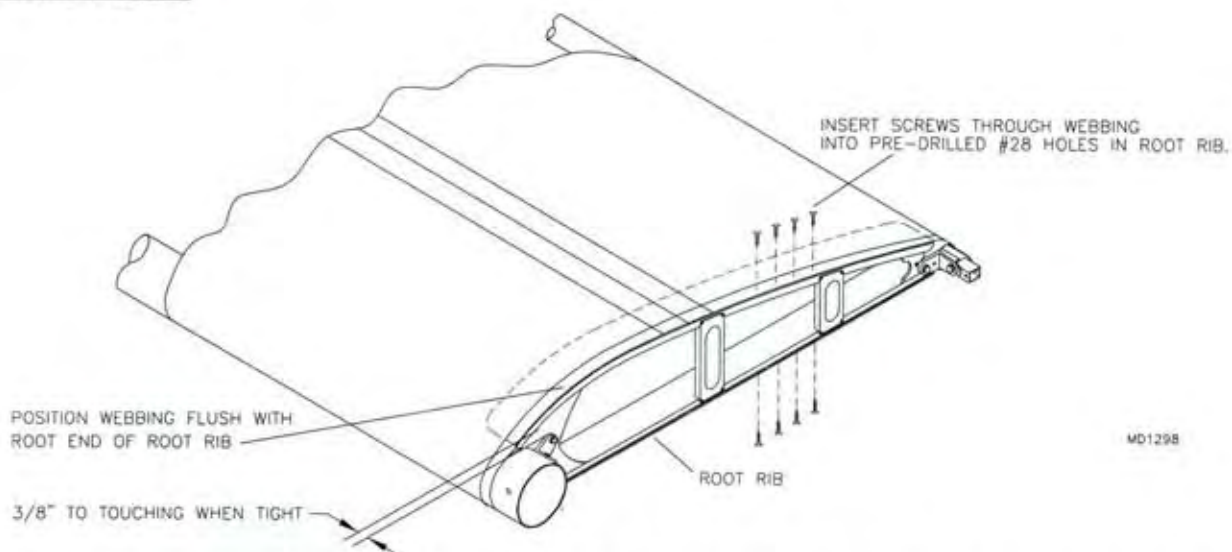
**FIGURE 023A-05B**



MD4263

6. Secure the skin to the root rib by installing the proper screws through the webbing of the skin into the pre-drilled holes in the root rib. See **Figure 023A-06**. Tension the skin by evenly tightening the two 1/4" tensioning bolts until the root rib is from within 3/8" to touching the "L" brackets.

**FIGURE 023A-06**

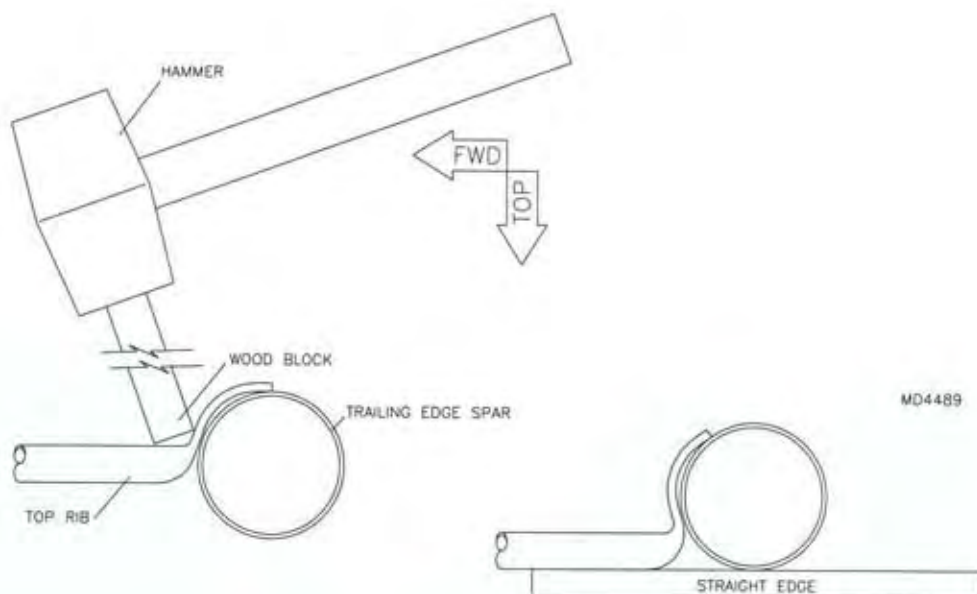


7. With the wing upside down, cut a slit for each rib pocket. **NOTE:** Only cut on the bottom surface of the wing. Refer back to **Figure 023A-05A**.

8. With the wing upside down, install the top ribs through the slits made in the bottom pockets. **IMPORTANT:** Be sure the ribs insert into the sewn pockets. **NOTE:** They should push in with a good degree of pressure. Use a small mallet and gently tap in place. A short scrap of lumber works as an excellent driving ram. That sound you are hearing is not the stitches ripping, but the 2-way tape popping loose. This is perfectly normal and does not affect the strength of the skins. The ribs do drive in hard, but be careful of the last one near the wing tip. It may try to jam under the tip wrap. If it does, push the fabric from the bottom at the leading edge to help it line up. **PLEASE NOTE:** In some places rivets or nut plates may hang up the aft curve of the rib. Simply move the rib to either side to clear.

9. The aft end of the top ribs must be rotated into place against the aft spar. Using a small block of wood and a hammer, push the rib aft and toward the top skin. See **Figure 023A-09**. This will rotate the top of the rib inline with the aft spar and allow the bottom rib to set against the spar.

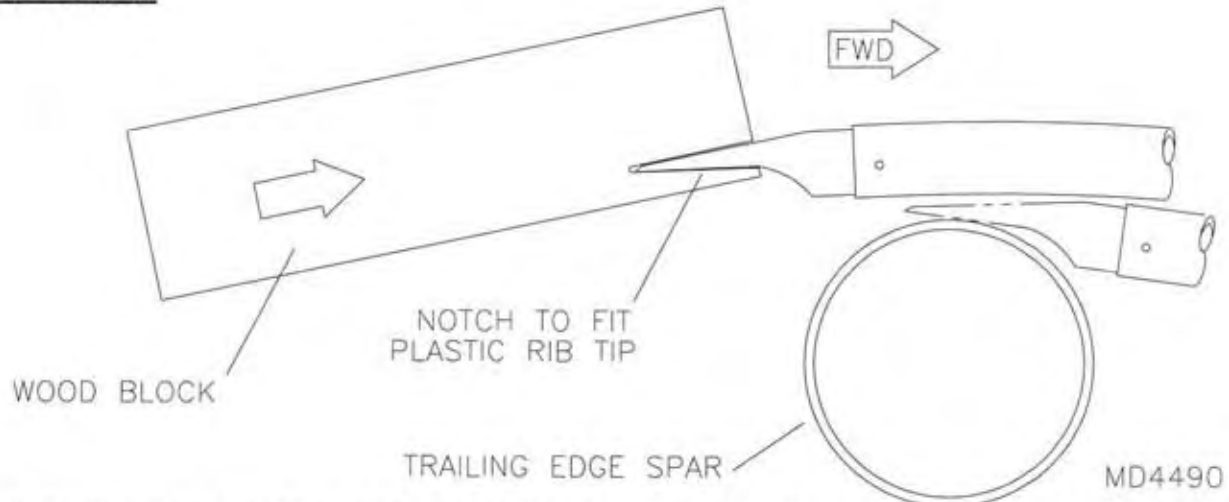
**FIGURE 023A-09**





10. Install the bottom ribs the same way, except to get them started insert the rib upside down, this will help the tip slide into the pocket, then turn it right side up (tip curve down). Push the rib into place. **HINT: Make a push block from wood.** See **Figure 023A-10**. The bottom rib tip will lie against the bottom of the trailing edge spar sealing shut the slit made for rib insertion. Top rib removal is done by making a tool from an old screwdriver. Heat and bend the end into a 90 degree hook. Use the tool to reach up inside the slit to grab a rib and pull it out. Always remove the bottom rib first.

**FIGURE 023A-10**

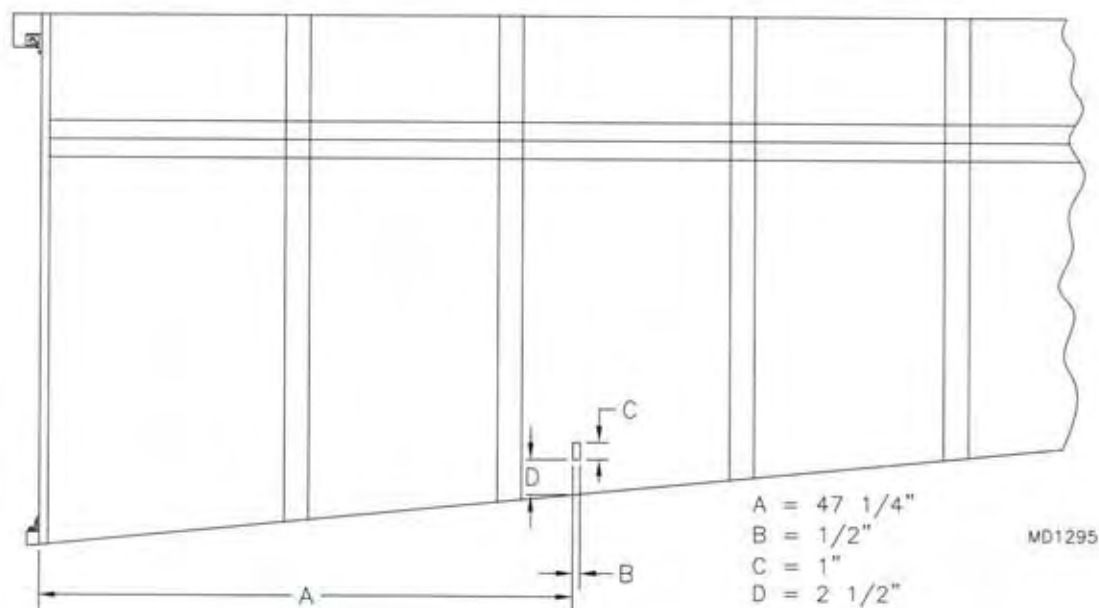


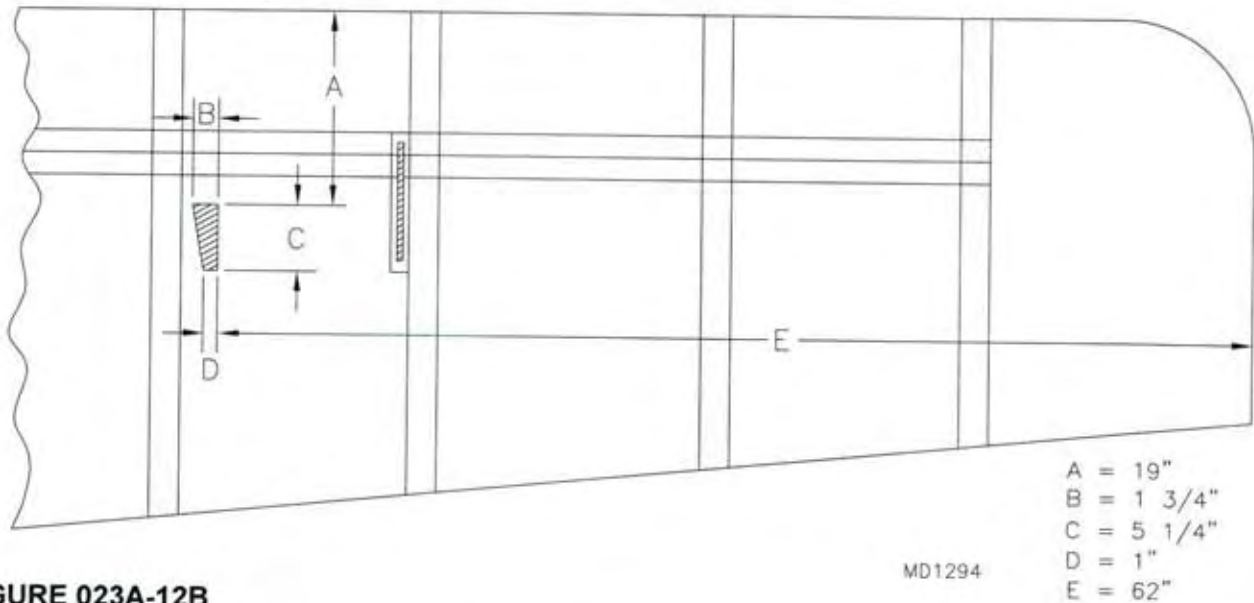
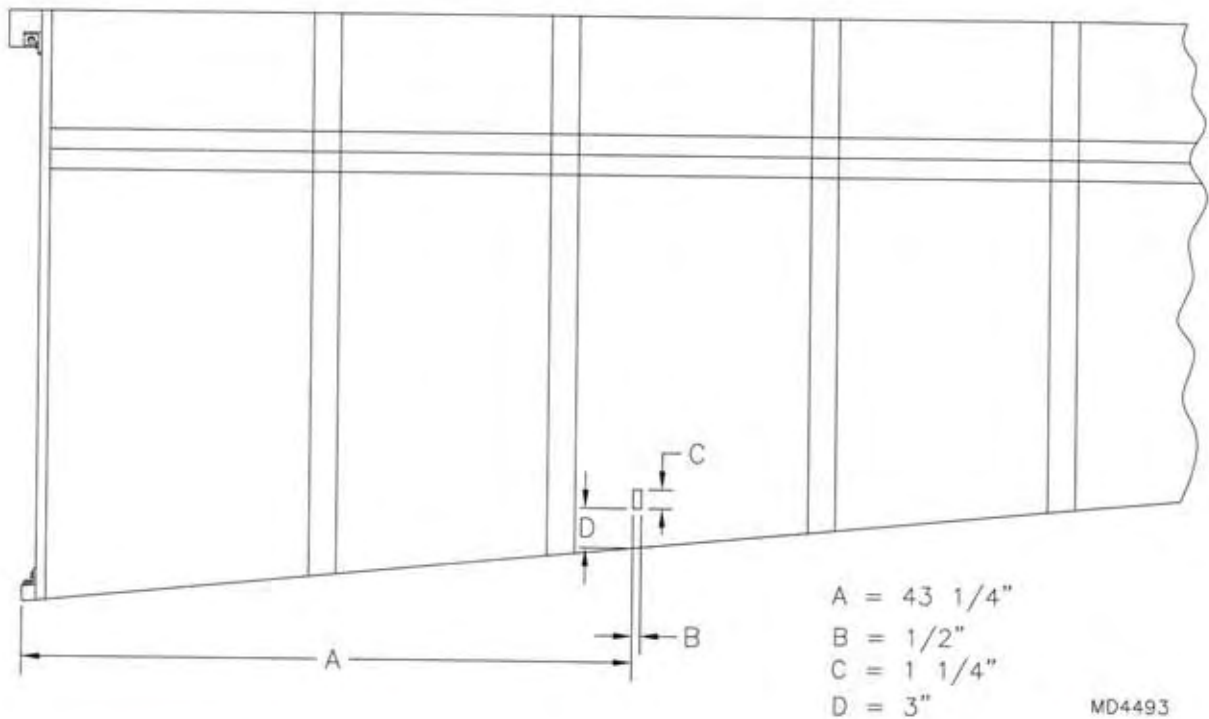
11. Smooth out any wrinkles or fold lines in the wing skins with a household electric iron. Be careful not to melt the skins. 350 degrees is the maximum temperature used. After 350 degrees the cloth will stop shrinking and start stretching. A hot air gun or model airplane heat gun used for shrinking mono-coat works great for the stubborn areas. **CAUTION: Be very careful!! Hot air guns create very high temperatures and can melt through Dacron very easily and very quickly.** **HINT: Angle the hot air gun to blow across the skin rather than directly at it and keep the nozzle moving.**

12. Make cut outs around the fuel tank filler, strut attach plates and jury strut tabs by following around the protrusion with a hot knife. Re-shrink the surrounding skin as needed. Locate and cut holes for the flap and aileron exits as shown in **Figure 023A-12** and **Figure 023A-12A**. Locate and cut the hole for the Aft Jury Strut exit as shown in **Figure 023A-12B**. Cut open each zipper. **NOTE: If applying clear-coat, cut the exit holes and zippers after clear-coat is dry.**

**FIGURE 023A-12**

FLAP TELEFLEX EXIT LOCATION

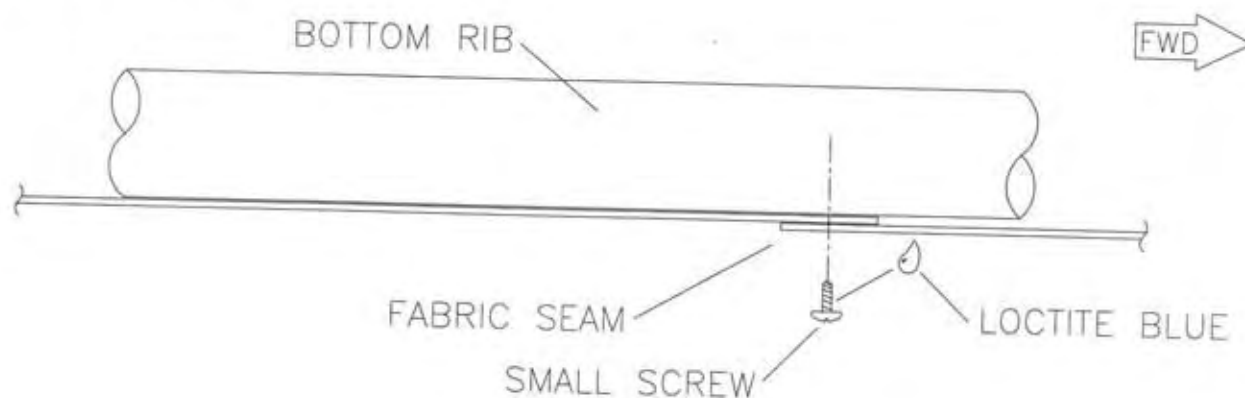


**FIGURE 023A-12A**AILERON PUSH PULL TUBE EXIT LOCATION**FIGURE 023A-12B**AFT JURY STRUT EXIT LOCATION

13. Melt holes for the static and pitot tubes. Push the pitot tube out by reaching inside through the zippers. Poke holes with the hot knife for the aileron and flap hinge bolts. Cut away the Velcro gap seals the same as it was done on the flaps and ailerons.

14. If clear-coat will **NOT** be applied to the wing, then to prevent the bottom rib from sliding out, it is required to install a small screw. Locate this screw through the bottom fabric on a seam where the fabric is doubled, such as one of the stripes. Drill a #40 hole through the fabric and rib. Place a small amount of Loctite on the screw and install. See **Figure 023A-14**.

**FIGURE 023A-14**



MD1296

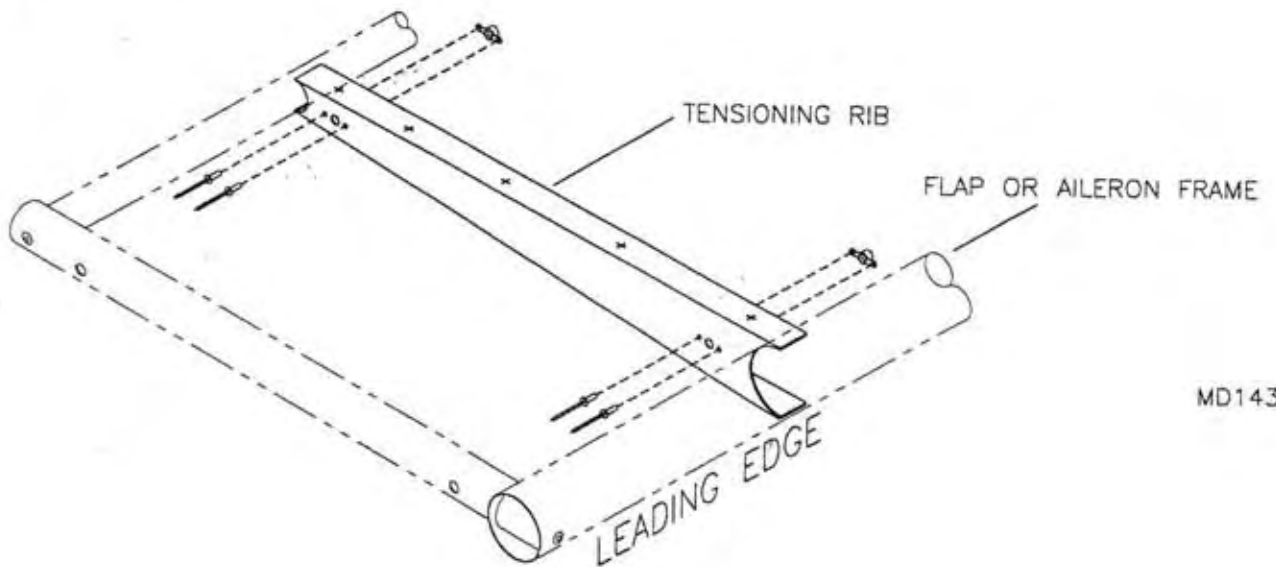
15. After attaching wings to the fuselage the bottom root gap seals may be installed. The bottom root gap seals are two sheet metal covers that fill the gap between the wing and fuselage on the wings underside. They must be fitted to the wing after the wings are attached. Look closely at the gap seals. You will notice there is a left and a right seal. The flange on the gap seals narrows to the AFT. **IMPORTANT:** To avoid hitting the screws that retain the wing covering apply a strip of masking tape along the bottom webbing. Mark on the tape where the screws occur. Apply a strip of foam rubber to the small flange. Hold the gap seal in position and mark for five screw locations. Locate the end screws about 3/4" inside of the root rib. Place as near the center as possible. Locate the last two screws half way between the center and the ends. Drill through the gap seal and into the root rib with a #30 bit. Install #6 pan head screws.

## COVERING THE AILERONS & FLAPS - STD. & 116

**NOTE:** Covering instructions for the Area II flaps and ailerons are at the end of the section.

1. Install the tensioning rib into the interior of the flap or aileron at their tensioning end. Note the orientation of the tensioning rib. Slide the tensioning rib against the 5/8" diameter tube with the two #11 holes in it. Using the holes as a guide mark the locations onto the tensioning rib. Remove the tensioning rib and drill the holes to #11. Install the nut plates to the inside of the tensioning rib. Refer to the parts drawing and to **FIGURE 023B-01**. Install the tensioning rib into the flap or aileron frame using the bolts called out on the parts page. Just start the bolts into the nut plates at this time.

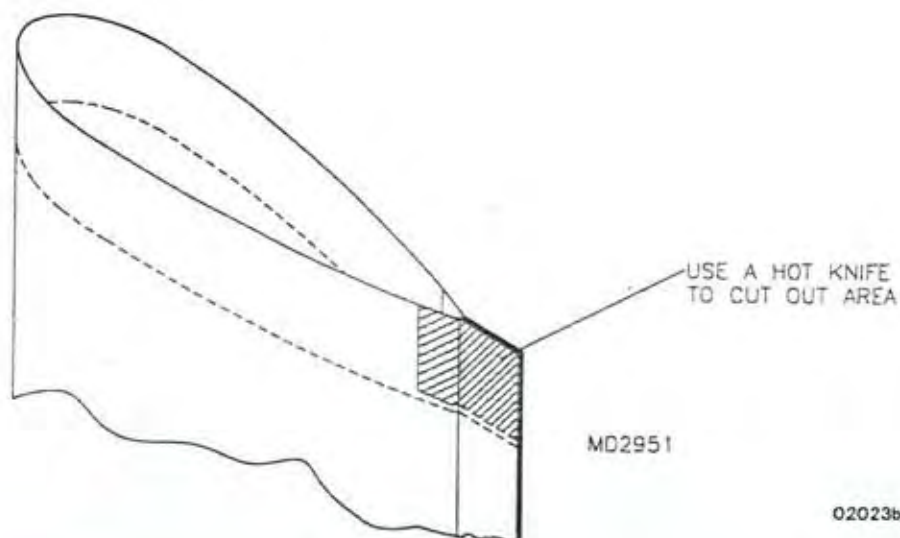
**FIGURE 023B-01**



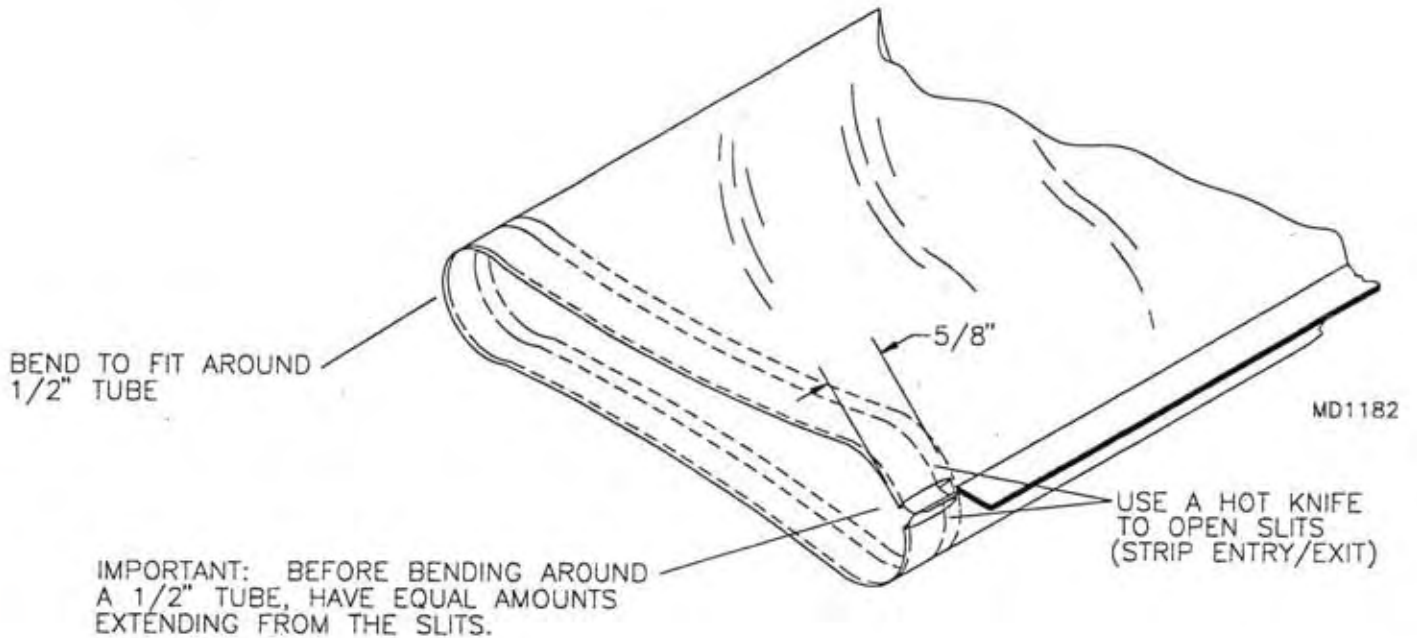
MD1431

2. Cut a small notch in the leading edge of the pocket, in the open end of the skin. Cut back from the velcro a notch a little less wide than the pocket. Do not cut into the stitches. See **FIGURE 023B-02**.

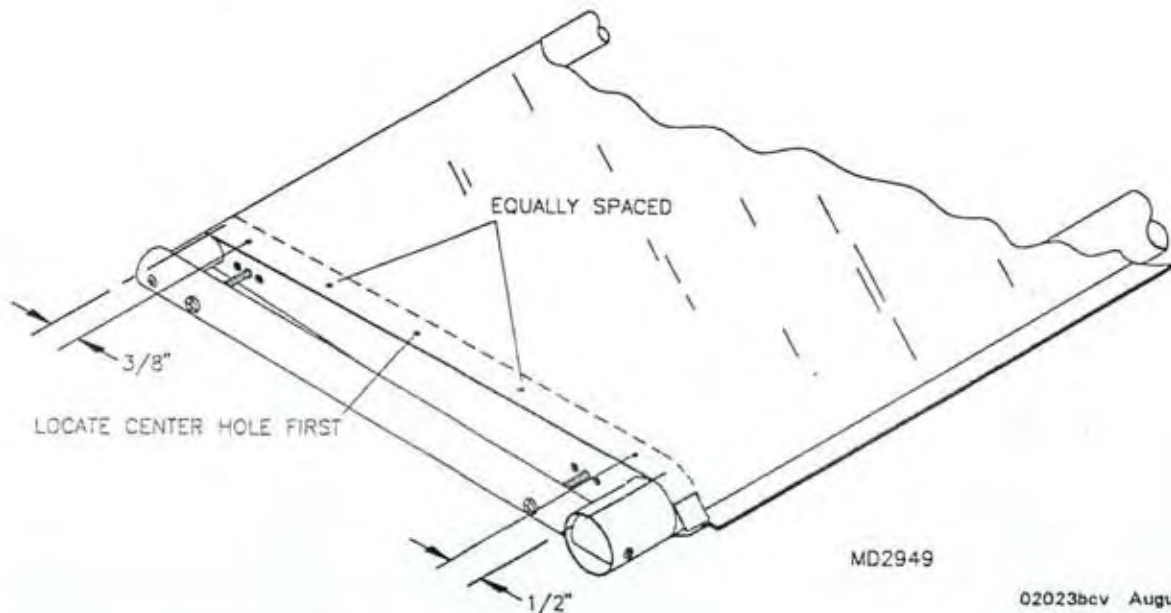
**FIGURE 023B-02**



3. Insert the aluminum strips into the skin pocket so that equal amounts are extending out of the pocket. Determine the center of the trailing edge and form the aluminum strip and fabric into a radius that will conform to the trailing edge spar of the flap or aileron. See **FIGURE 023B-03**.

**FIGURE 023B-03**

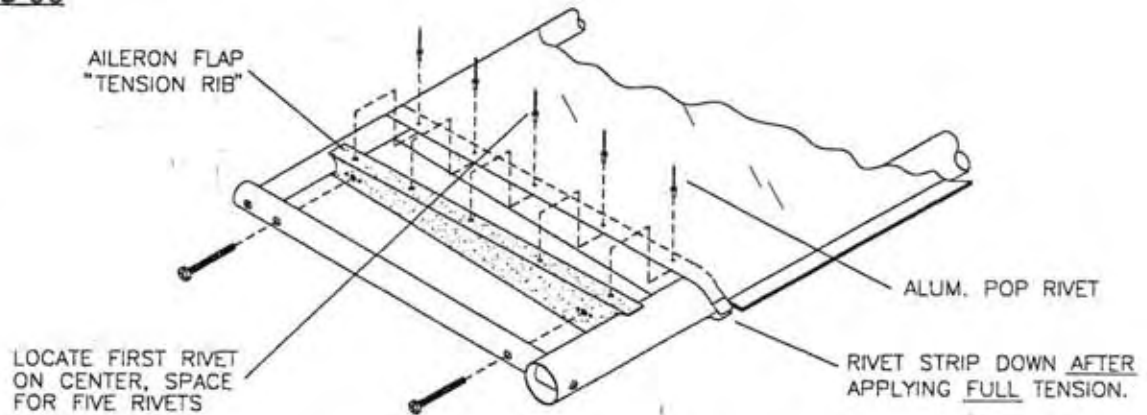
4. Layout and drill the hole pattern through the skin and the aluminum strip as shown in **FIGURE 023B-04**. Use caution when drilling through the fabric so as not to snag or tear. Also be mindful of the aluminum shavings gathering between the fabric. An alternate method is to remove the aluminum strip and pre drill prior to inserting it into the skin.

**FIGURE 023B-04**

5. Slip the skins over their respective frames. Note that there is a left and right hand skin. The "sticky" side of the velcro is up. The skins will fit tight but they will go on. **HINT:** Brace the tensioning end of the frame against a wall or solid object to push against as you pull on the skin. After about half way on pull the skin down from the top. This will bunch the skin up but now you will have less tension to pull against. In extreme cases where the skin is too tight (it will be evident by the bowing in the trailing edge between ribs) lightly file some length off of the trailing edge of the compression ribs.

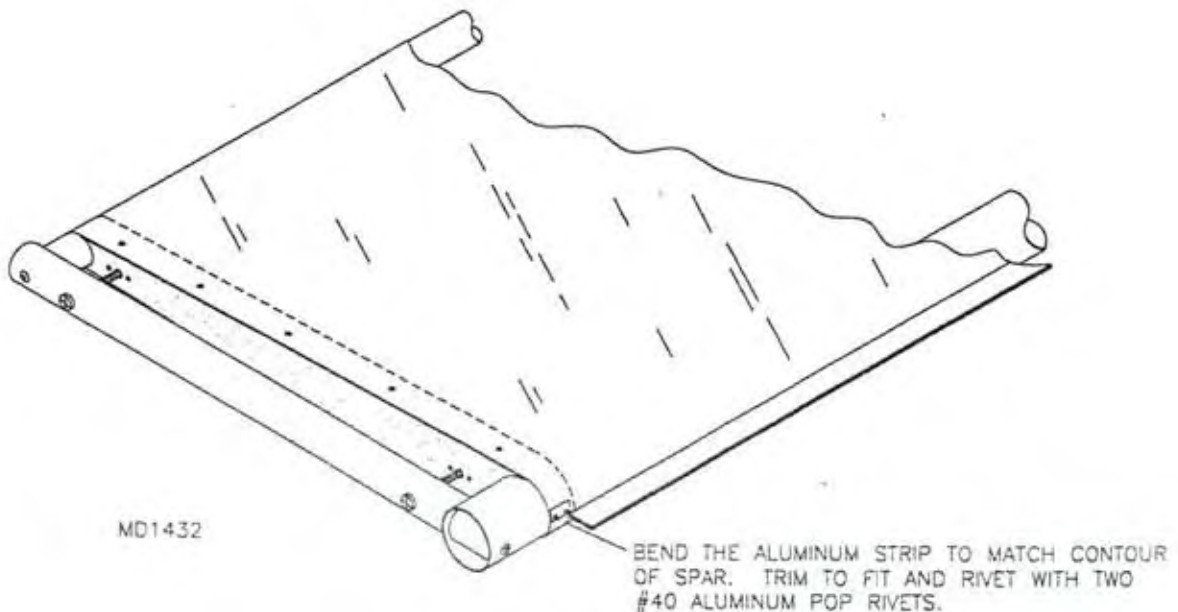
6. With the tension rib fully extended pull the fabric on until it is flush with the end of the tensioning rib. Transfer drill through the aluminum strip into the tensioning rib and rivet the fabric and aluminum strip to each side of the rib. See **FIGURE 023B-06**. Tension the skin by evenly tightening the two screws. The proper amount of tension is achieved when the rib bottoms against the 5/8" tube. See **FIGURE 023B-06A**. Trim the aluminum strip and form it around the spar as shown in **FIGURE 023B-06A**. Place two #40 aluminum rivets through the aluminum strips into the spar.

**FIGURE 023B-06**



MD1431

**FIGURE 023B-06A**



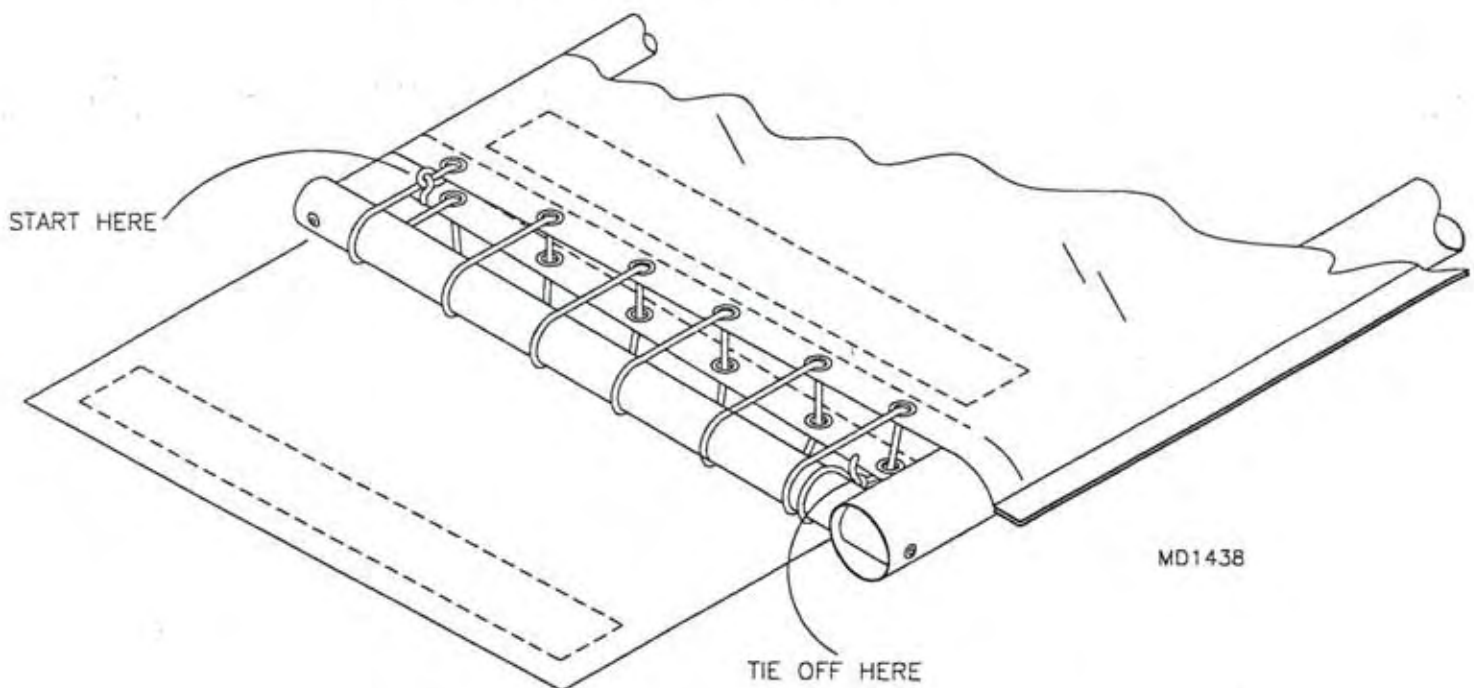
MD1432

## AREA II FLAPS AND AILERONS

7. Pull the skins onto their respective frames. Note that there is a left and right hand skin. Cut a piece of lace up cord to length. Tie off one end of the cord to one of the grommets. Lace the cord through the grommets as shown in **FIGURE 023B-07**. Tension the skin by drawing up the lace up cord. Do not try to fully tension the skin in one tensioning pass. It will take several times of systematically tensioning to bring the skin to final tension. When final tension has been achieved, tie off the loose end of the lace up cord and wrap the dacron flap around to the velcro strip.

**FIGURE 023B-07**

### AREA II FLAP AND AILERON SKIN TENSIONING METHOD



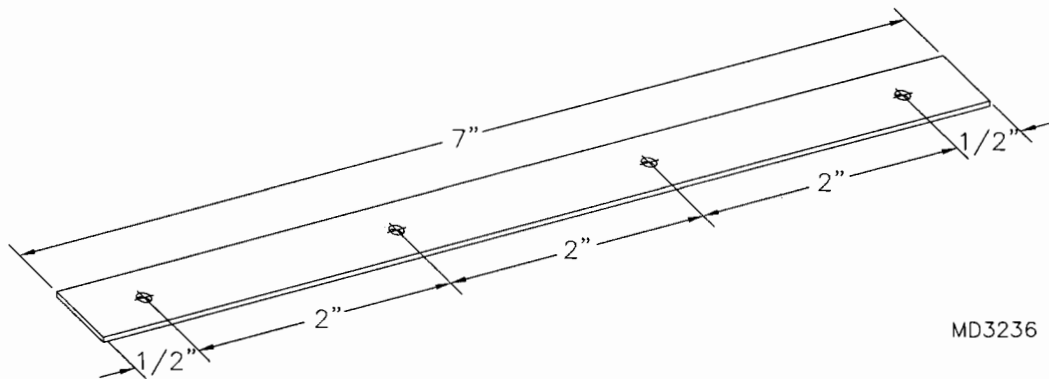
**S-6ES COYOTE II****FUSELAGE COVERING**

**IMPORTANT:** Wash your hands and keep the work area clean. At this point the aircraft should have wings, tail, landing gear and cowling removed. Set the fuselage on a set of sawhorses. **HINT:** Clean towels on the sawhorses will help protect the skin.

**NOTE:** Step 1 is for Taildraggers only. If you are skinning a Trike, skip this step.

1. Install the Lacing Wires in the 8" Lace Up Strips, as described in step 6 below. Layout and mark the hole pattern in the 8" Lace Up Strips as shown in **FIGURE 023B-06A**. Fabricate the two aluminum strips to the dimensions called out in **FIGURE 023B-01**. Locate and drill the #40 holes in the aluminum strips. Fold the 8" Lace Up Strips in half. Place the aluminum strips tight into the fold of the Lace Up Strips. Melt through both sides of the Lace Up Strips at the hole locations in the aluminum strips. Position the aluminum strip on the under side of the Gear Leg Socket Gusset next to the Bottom Longeron. Transfer drill #30 through the aluminum strips into the gussets. Refer to the parts drawing. **CAUTION:** Do **NOT** drill into the bottom longeron. Debur and clean out all shavings. Rivet the lace up and aluminum strips to the bottom of the gusset.

**FIGURE 023C-01**



MD3236

2. Before skinning the fuselage, please inspect for completion and proper assembly using the following check list.



## Pre-covering checklist:

- All Tubes, Gussets and Fittings, bolted, riveted and secured.
- Gear Set
- Taildragger - Anti-crush Bushings - JB Welded in Bottom Longeron
- Optional Antenna Mount Plate Installed
- Floorboard Fit-up
  - Oriented correctly – narrow end forward
  - Bolted in Fuselage
- Nut Plates Installed
  - Floorboard & Rudder pedal (12)
  - Horizontal Attach on Top Longeron (4)
  - Cable attach at lower Station-6 (2) & Bushings JB welded
  - Tie down or tailspring – 1/4" (Trike 2) (Taildragger 4)
  - Flap Teleflex Retainer – Station 3 (2)
- Station 3 – Top pulley bolts (2)
- Stringers
  - Side stringers
  - Belly stringers
  - Top stringer
- Forward Contour Formers Installed
- Rudder Cable Guides installed – Lower Station-6
- Rudder Cables installed and secured at Station 3 & 6
- Elevator Push Pull tube installed & secured
- Longeron Fairings Installed
- Horz. Stab. Brace Tube – Upper Station-6
- Top and Bottom Gussets riveted
- Diagonal Tailcone Cables – Bolted, with 1/8" tubing anti-chaff at cable intersections
- Station 6 Top Cross Tube drilled to #11
- Station 1 Top Former installed to correct height
- Firewall w/soundproofing riveted
- S-1 Lace tube bolted to Firewall
- Optional Aft Baggage Installed – door, hinges & capture strips drilled and removed
- All Rivets flush
- Marks removed

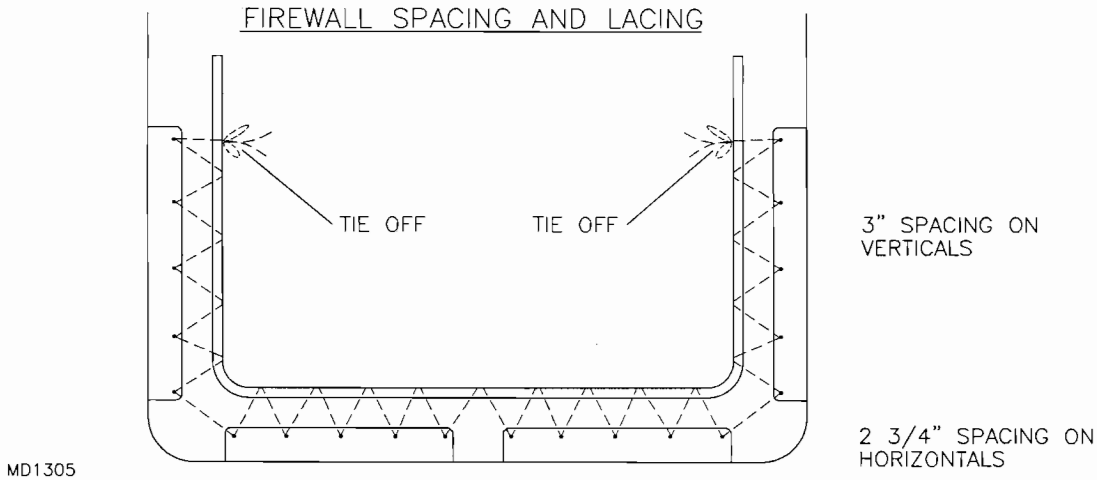
3. Open the belly Velcro and slip the fuselage cover over the fuselage starting at the tailcone. Have a friend hold the covering off the floor as you slide it forward. Pull the bottom between the Gear Leg Sockets. Position the pre-cut holes over the Strut Attachments. Continue forward with the covering, wrapping the sides over the cockpit edges. Use clothes pins or masking tape to hold the sides in place.

4. Cut the rope provided into the lengths specified for each lacing area. See the chart below. Use a hot knife or soldering iron. **HINT:** Roll the molten nylon into a needle like point to help with lacing.

TYPE	FT	QTY
Belly Rope	20	1
S-1 Rope	17	1
S-3 Vertical	5	1
S-3 Horizontal	4	2
S-3 Diagonal	5	2
7" Lace Up Strip	11	2
13" Lace Up Strip	11	2
10" Lace Up Strip	6	2
8" Lace Up Strip	5	2

5. Layout, mark and burn the holes for the firewall lacing. Refer to **FIGURE 023B-05**. Use a soldering iron (or hot knife with a point) to melt through to make holes for the Lacing Rope. **IMPORTANT:** Do not melt through the reinforcing on the very edge of the skins. Loosely lace up the firewall area.

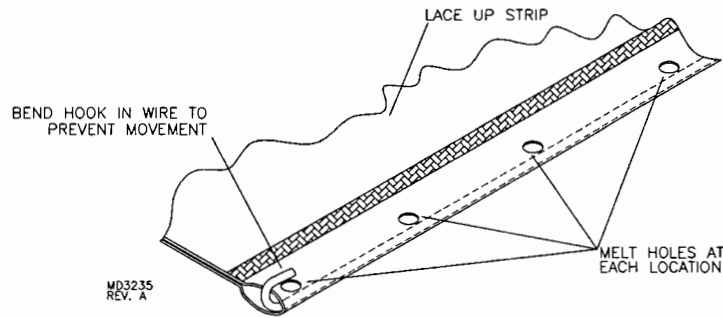
**FIGURE 023B-05**



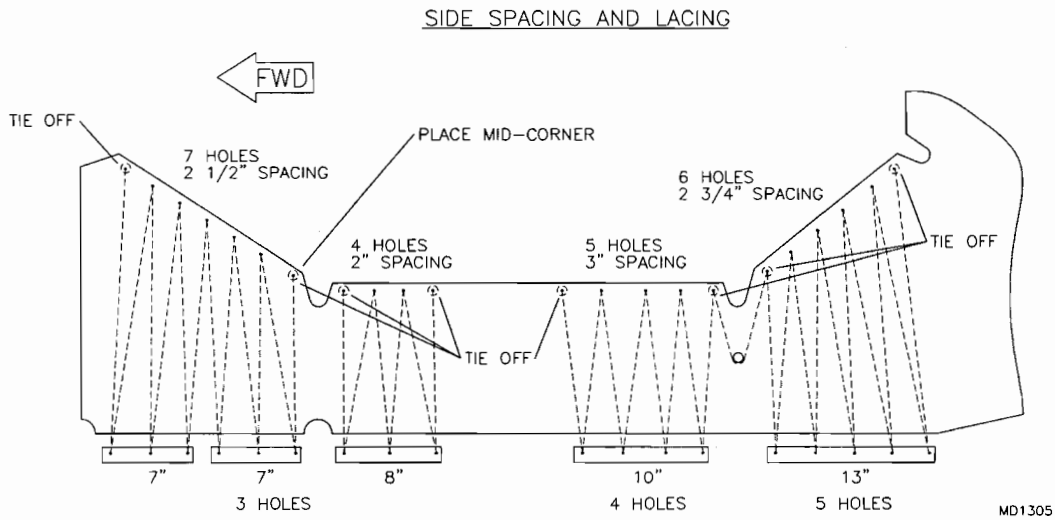
6. Pull the skin aft, with the Cinch Straps, to overlap the forward edge of the Tail Channel by about 3/8" to 1/2". Secure by passing the straps through and under the buckle.

- Cut to length and install the Lacing Wires into each pocket in each Lace Up Strip. Bend a hook on each end of the wires to prevent movement. Refer to **FIGURE 023B-07**. Mark off the Fuselage Side and Lace Up Strip hole locations as shown in **FIGURE 023B-07A**. Use a soldering iron (or hot knife with a point) to melt through to make holes for the Lacing Rope. Wrap the Lace Up Strips around the Fuselage Bottom Longerons at each respective location.

**FIGURE 023B-07**



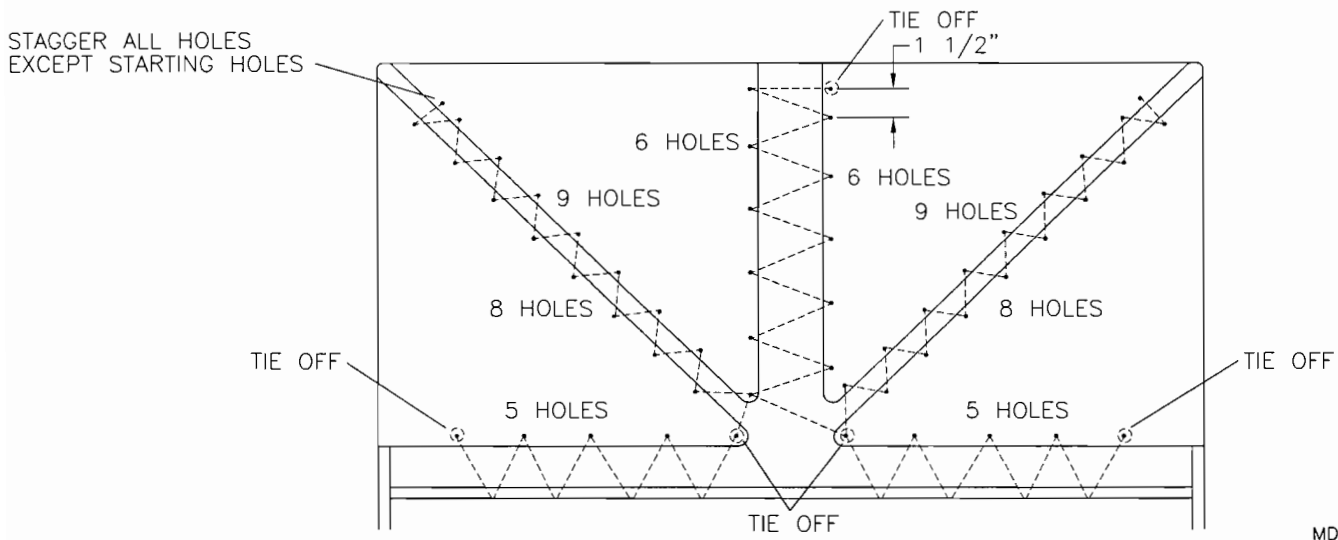
**FIGURE 023B-07A**



- Layout, mark and burn the holes for the Station 3 lacing. Refer to **FIGURE 023B-08**. Loosely lace up Station 3.

**FIGURE 023B-08**

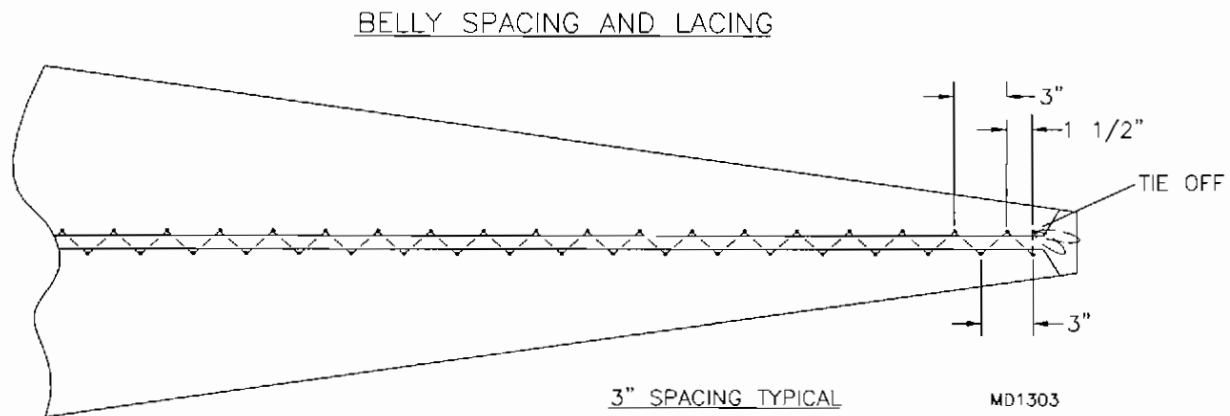
STATION 3 SPACING AND LACING



- Lay out, mark and burn the hole locations on the belly split as per **FIGURE 023B-09**. **NOTE:** These

holes are to be staggered 1 1/2" to evenly pull together the bottom. **IMPORTANT:** Do **NOT** bum into the belly flap.

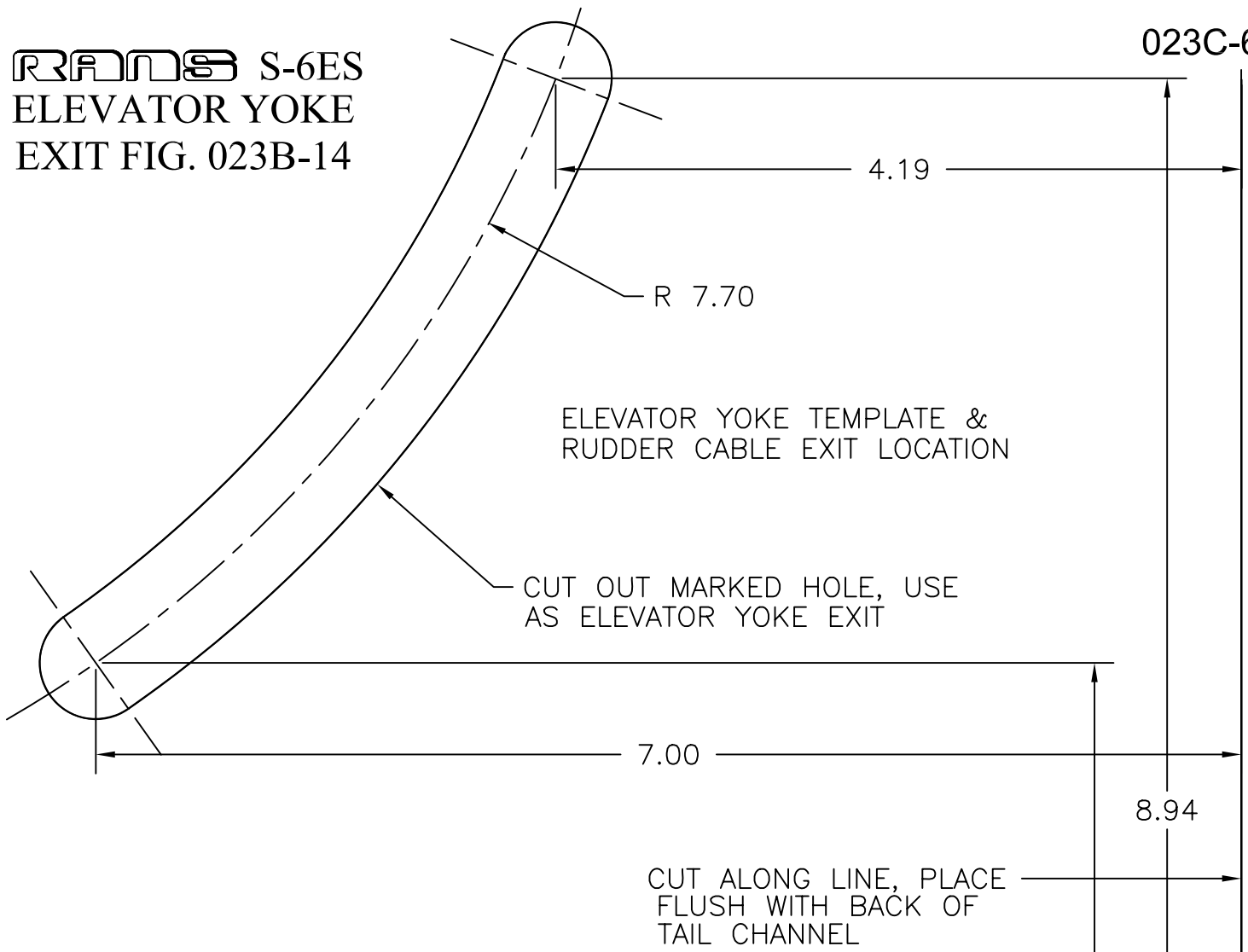
**FIGURE 023B-09**



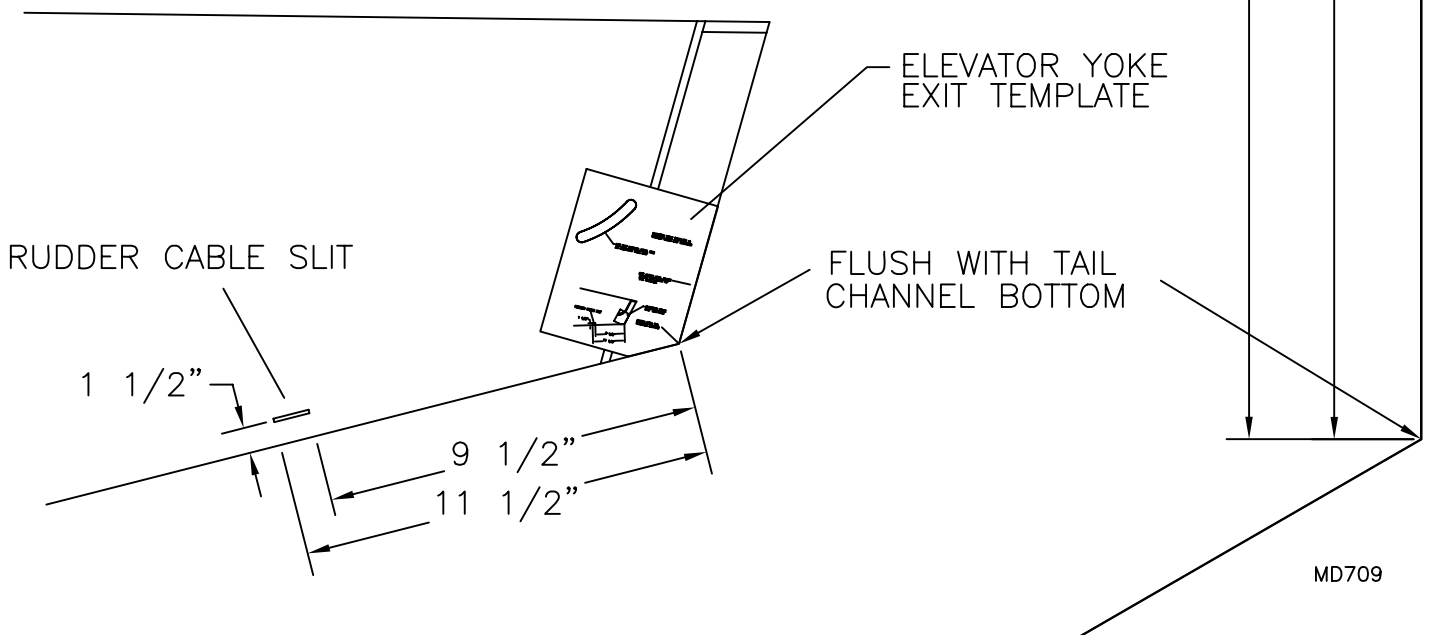
10. What we are working towards, in covering the fuselage, is a perfectly smooth and tight finish. This is achieved by applying even tension everywhere. That's the theory!! In practice it will vary, but localized excessive tension can induce wrinkles. To get the best fit it is recommended you lace up the cockpit areas first. **IMPORTANT:** Do **NOT** try tightening one area to final tension, work around (much like torquing prop bolts, cross over to the other side). By working each lace up a little it will even out the tension. FWD and AFT tension will smooth out the side panels. This is set by the Firewall Lacing and Cinch Straps at the tail. No more than a 3/8" gap should appear between the Tail Channel and fabric. **HINT:** Tension 90° to the wrinkle.
11. Belly lacing is done after you have completed the cockpit area. Pull the belly together slowly by tying off the front end and pulling the slack out towards the tail. Do **NOT** pull excessive tension; work it out in multiple pulls. If you have over tightened the tailcone the bottom longerons will be warped and wrinkles will be apparent. Close the Velcro Belly Flap after the final tensioning.
12. The fuselage cover should be complete. Minor looseness or wrinkles can be ironed out. However, be careful. **CAUTION:** Temperatures over 350°F can melt the fabric. An older household iron with a heavy sole works best. Also, some colors may show ironing marks. A hot air gun works too, but again be especially careful of melting.
13. If you plan to clear coat the aircraft, be careful not to soil the fabric during the rest of the assembly process. Clear coating the fuselage at this point is wise only if the rest of the aircraft is coated within 30 days. The urethane may set up in the can after 30 days of being opened even though no catalyst has been added.
14. With the skin in place and stretched tight, hot knife the holes in the locations for bolting on the tail. Hot knife the Gear Leg Socket openings. **NOTE:** Cutting these holes slightly small to allow a tight fit on the gear leg. Use the template for the elevator yoke and rudder cable exit to locate and cut out opening. See **FIGURE 023B-14**. If clear coating this step may be done afterwards.

**RANS S-6ES**  
**ELEVATOR YOKE**  
**EXIT FIG. 023B-14**

023C-6



IMPORTANT: WHEN PRINTING OR COPYING THIS  
TEMPLATE, CHECK DIMENSIONS FOR CORRECT  
SCALING OF FINAL PRINT



## RANS CLEAR COATING & PAINTING

### CLEAR COATING DACRON COVERED SURFACES

Dacron surfaces will benefit greatly from the UV protection a clear coat of polyurethane can provide. A complete RANS clear coating video, including useful tips learned from many years of clear coating Dacron skins, is available from the RANS parts department. The basic method, briefly described below, is the "Deluxe System". Stop after step 6 for the "Standard System". **NOTE:** *Always follow the manufacturer recommendations on ventilation and respiratory equipment.*

The RANS process is as follows:

1. Clean the Dacron skins with lacquer thinner.
2. Remove any frayed or excess threads using a razor blade.
3. Remove any dust particles by using a high-pressure air nozzle (approximately 100psi) and a tack cloth.
4. Tape off Velcro gap seals. **Hint:** *Purchase Velcro and attach to the gap seal to protect from the clear coat.* Tape over zippers to allow opening after clear coating.
5. Apply an adhesion promoter (we use Dupont 222S Mid-coat adhesion promoter) according to the manufacturer recommendations.
6. Apply two coats of clear. Apply the second after the first has "tacked" according to manufacturer recommendations

In this step we use:

- 3 parts Dupont 72200S Premier
- 1 part Dupont 12305S Activator-Reducer
- 1 part Dupont 12375S Low-temp Reducer\*

\*(Reducer type will depend on temperature and humidity 12375S is for 75 degrees. If spray environment is closer to 95 degrees use 12395S. 12375S and 12395S may be mixed as needed for temperature. Reducer quantity will depend on the type of flow you desire. Use more to obtain thinner flow or less to have a slightly thicker flow).

Let these two coats dry 24 hours.

7. Sand with 400 wet sand paper. Always use water when sanding. Do not sand the stitching of the fabric; instead use a Scotch-Brite pad to go around the stitches. Rinse, allow to dry thoroughly. Remove any residue with a tack-cloth.
8. Apply one or two more coats of clear.

In this step we use:

- 3 parts Dupont 72200S Premier
- 1 part Dupont 12305S Activator-Reducer
- 1 part Dupont 12375S Low-temp Reducer\*

Let these two coats dry 48 hours before handling.

- For even more information on clear coating, call the RANS parts dept. for information on the RANS clear coating process video.

## PAINTING ALUMINUM SURFACES

Aluminum surfaces such as cowlings, gear leg fairings, etc. should be painted as below. **NOTE:** Always follow the manufacturer recommendations on ventilation and respiratory equipment.

The RANS process is as follows:

1. "Scuff" the surfaces using medium Scotch-Brite to help the primer adhere.
2. Clean surfaces using lacquer thinner.
3. Apply two coats of self-etching primer (we use Dupont Variprime) according to the manufacturer recommendations.
4. Apply the paint chosen. It is recommended to use paint from the same manufacturer as the primer you applied to ensure chemical compatibility. If you are satisfied with the finish, painting can be the last step.
5. Clear coat if even more gloss and protection is desired (we use Dupont 72200S Clear coat for aluminum surfaces).

## PAINTING PLASTIC SURFACES

Plastic surfaces such as wing fairings, cuff fairings, etc. should be painted as below.

**NOTE:** Always follow the manufacturer's recommendations on ventilation and respiratory equipment.

The RANS process is as follows:

1. "Scuff" the surfaces using medium Scotch-Brite to help the primer adhere.
2. Clean surfaces using lacquer thinner.
3. RANS has found a primer is not necessary, as long as the surface is scuffed properly. A special "Plastic" primer may be applied if desired. Contact your paint manufacturer for details.
4. Apply the paint chosen. If you are satisfied with the finish, painting can be the last step.

## PAINING FIBERGLASS SURFACES

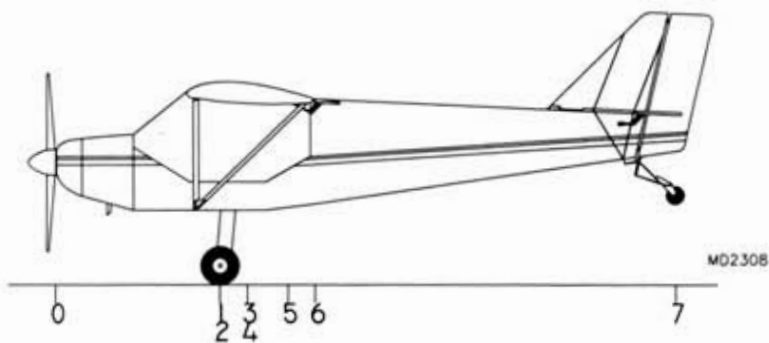
Fiberglass surfaces such as cowlings and windshield decks should be painted as below.

**NOTE:** Always follow the manufacturer recommendations on ventilation and respiratory equipment.

The RANS process is as follows:

1. Clean surfaces with Rubbing Alcohol to remove the fiberglass release agent.
2. Sand with 320 sandpaper.
3. Fill imperfections with Body Putty or Finishing Glaze. Sand smooth.
4. Apply 2 to 3 medium coats of primer (we use Dupont 1140S) according to the manufacturer recommendations.
5. Sand with 320 sandpaper.
6. Apply the paint chosen. It is recommended to use paint from the same manufacturer as the primer you applied to ensure chemical compatibility. If you are satisfied with the finish, painting can be the last step.





~~RAMS~~ S-6ES COYOTE II  
 (STD & 116 WING) WEIGHT AND BALANCE  
 STARTING WITH SER. # 12021472

N _____	
DATE WEIGHED	
ENGINE TYPE	
C.G. CONDITION	
EMPTY WEIGHT	

STANDARD WING	
MTOW (503)	1000 LBS.
MTOW (582)	1030 LBS.
MTOW (912)	1100 LBS.

116 WING	
MTOW (582)	1100 LBS.
MTOW (912)	1200 LBS.

ACCEPTABLE C.G. 62.5" TO 73" FROM DATUM 0.  
 DATUM 0 = BACKSIDE OF PROP. AIRCRAFT IN  
 LEVEL ATTITUDE. (LEVEL REFERENCE TO  
 BOTTOM OF DOOR.)

#	ITEM	WEIGHT	ARM	MOMENT
1	MAIN RH	225	55.5"	12488
2	MAIN LH	230	55.5"	12765
3	WING TANKS 18 GAL.	108	72"	7776
4	PILOTS	340	72"	24480
5	BAGGAGE *	50	90"	4500
6	AFT BAGGAGE **	30	105"	3150
7	TAILWHEEL	31	226"	7006
TOTAL=		1014	TOTAL=	72165

$\frac{\text{TOTAL MOMENTS}}{\text{TOTAL WEIGHT}} = \text{C.G.}$

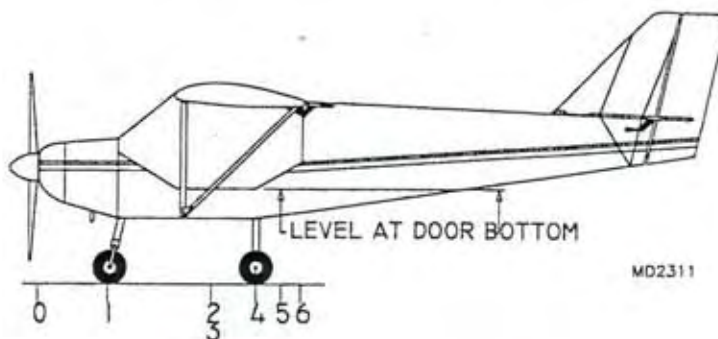
$\frac{72165}{1014} = 71.17$

#	ITEM	WEIGHT	ARM	MOMENT
1	MAIN RH		55.5"	
2	MAIN LH		55.5"	
3	WING TANKS 18 GAL.		72"	
4	PILOTS		72"	
5	BAGGAGE *		90"	
6	AFT BAGGAGE **		105"	
7	TAILWHEEL		226"	
TOTAL=			TOTAL=	

$\frac{\text{TOTAL MOMENTS}}{\text{TOTAL WEIGHT}} = \text{C.G.}$

\_\_\_\_\_ =

- \* 50 LBS. MAXIMUM BAGGAGE
- \*\* 30 LBS. MAXIMUM BAGGAGE



~~RRMS~~ S-6ES COYOTE II  
(STD. WING) WEIGHT AND BALANCE

N _____	
DATE WEIGHED	
ENGINE TYPE	
C.G. CONDITION	
EMPTY WEIGHT	
MTOW (503)	930 LBS.
MTOW (582)	975 LBS.
MTOW (912)	1010 LBS.

ACCEPTABLE C.G. 62.5" TO 73" FROM DATUM O.  
DATUM = BACKSIDE OF PROP; AIRCRAFT IN  
LEVEL ATTITUDE. (LEVEL REFERENCE TO  
BOTTOM OF DOOR.)

#	ITEM	WEIGHT	ARM	MOMENT
1	NOSE WHEEL	115	26"	2990
2	PILOTS	340	72"	24480
3	WING TANKS 18 GAL.	108	72"	7776
4	MAIN WHEEL	170+168	78"	26364
5	BAGGAGE *	50	90"	4500
TOTAL=		951	TOTAL=	66110

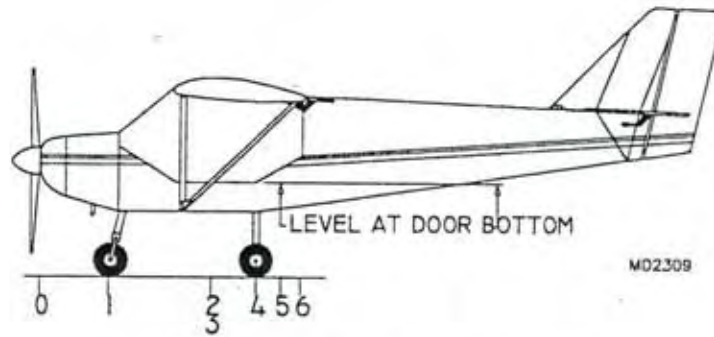
$\frac{\text{TOTAL MOMENTS}}{\text{TOTAL WEIGHT}} = \text{C.G.}$

$\frac{66110}{951} = 69.5$

#	ITEM	WEIGHT	ARM	MOMENT
1	NOSE WHEEL		26"	
2	PILOTS		72"	
3	WING TANKS 18 GAL.		72"	
4	MAIN WHEEL		78"	
5	BAGGAGE *		90"	
TOTAL=			TOTAL=	

$\frac{\text{TOTAL MOMENTS}}{\text{TOTAL WEIGHT}} =$

\* 50 LBS. MAXIMUM BAGGAGE



RAMS S-6ES COYOTE II  
(116 WING) WEIGHT AND BALANCE

N _____	
DATE WEIGHED	
ENGINE TYPE	
C.G. CONDITION	
EMPTY WEIGHT	
MTOW (582)	1000 LBS.
MTOW (912)	1100 LBS.

ACCEPTABLE C.G. 62.5" TO 73" FROM DATUM O.  
DATUM = BACKSIDE OF PROP; AIRCRAFT IN  
LEVEL ATTITUDE. (LEVEL REFERENCE TO  
BOTTOM OF DOOR.)

#	ITEM	WEIGHT	ARM	MOMENT
1	NOSE WHEEL	115	26"	2990
2	PILOTS	340	72"	24480
3	WING TANKS 18 GAL.	108	72"	7776
4	MAIN WHEEL	170+168	78"	26364
5	BAGGAGE *	50	90"	4500
TOTAL=		951	TOTAL=	66110

$$\frac{\text{TOTAL MOMENTS}}{\text{TOTAL WEIGHT}} = \text{C.G.}$$

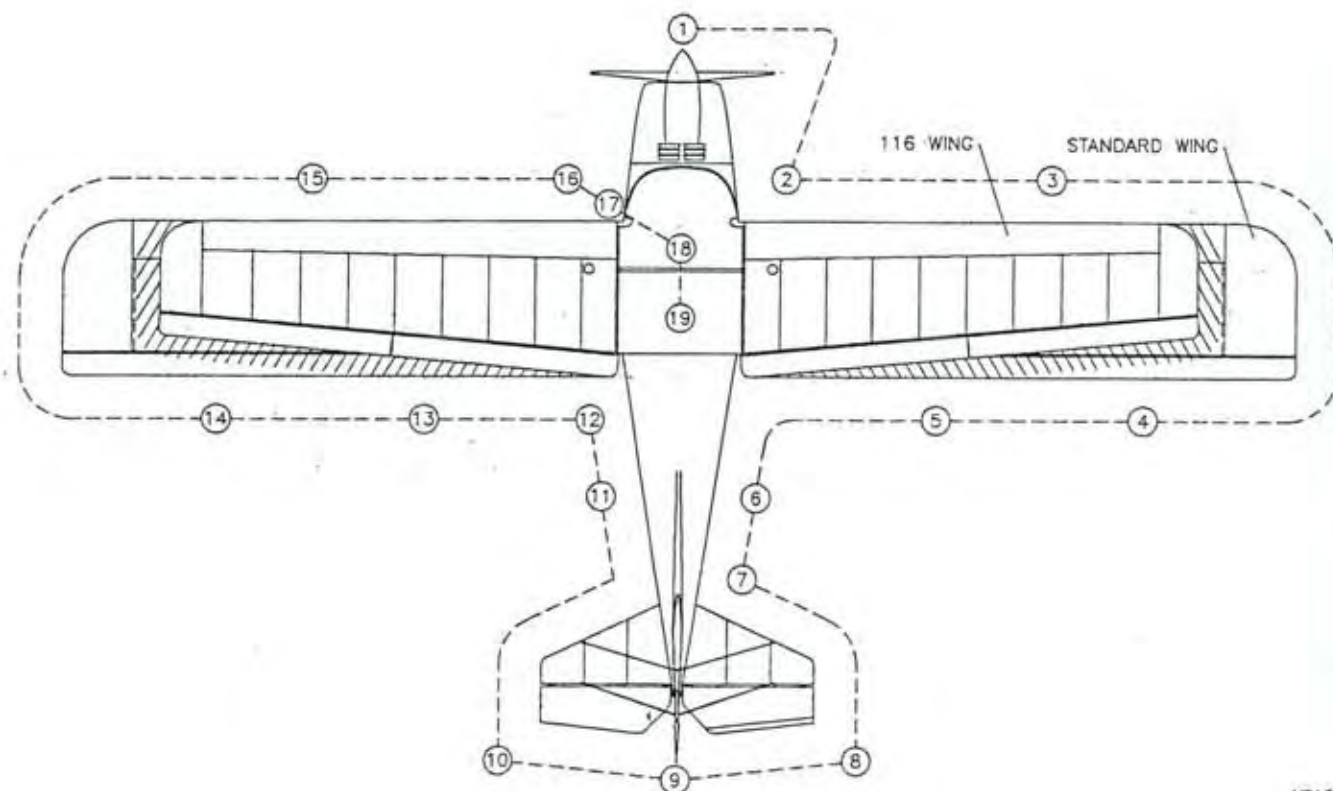
$$\frac{66110}{951} = 69.5$$

#	ITEM	WEIGHT	ARM	MOMENT
1	NOSE WHEEL		26"	
2	PILOTS		72"	
3	WING TANKS 18 GAL.		72"	
4	MAIN WHEEL		78"	
5	BAGGAGE *		90"	
TOTAL=			TOTAL=	

$$\frac{\text{TOTAL MOMENTS}}{\text{TOTAL WEIGHT}} =$$

\* 50 LBS. MAXIMUM BAGGAGE

## S-6ES & S-6XL COYOTE II PRE-FLIGHT INSPECTION



MD1321

1. Inspect the engine, mount, propeller, prop bolts, gear reduction system, gear box oil for leaks, cowling security, plug wires, air filter, carburetor position and clamp tightness.
2. Check the wing connections. Are all pins and bolts in place? Any signs of wear, cracks or bent tubing? Look over the landing gear. Tires inflated? Brakes secure?
3. Inspect the strut connections. Be sure the clevis pin is safetied. Look down the wing spar for bends. Is the covering taut? Open the zipper and look inside. Check the controls and inner wing structure.
4. Pre-flight the ailerons and flaps. Are the ribs in place? Hinge points secure? Does the control system operate freely? Do the flaps operate correctly?
5. Look over the jury struts. Are they bolted properly? Ribs in place? Is the trailing edge spar straight and intact?
6. Look over the tailcone area. Check for bent tubes, holes or tears in the fabric.
7. Inspect the tail surface connections to the tailcone. Are the fittings intact? Are all the bolts in place and secure?
8. Pre-flight the elevator. Move it up and down checking the hinge points.

9. Move the rudder. Inspect as in Step #8. Look over the nosewheel. Is it properly inflated? Check the steering rods. Does the nosewheel move freely when the rudder moves? Are all the control surface hinge points well lubricated and moving freely?
10. Repeat Step #8.
11. Repeat Step #6.
12. Repeat Step #6, plus check both fuel valves for on position (screw out) and is the filler cap closed?
13. Repeat Step #5.
14. Repeat Step #4.
15. Repeat Step #3.
16. Repeat Step #3.
17. Repeat Step #2.
18. Check the cockpit over. Are the seat adjusted? Move the sticks. Is everything moving as it should.
19. Climb aboard and go through the cockpit check list.
  - Buckled in?
  - Move the controls.
  - Set altimeter.
  - Note fuel quantity.
  - Note Hour Meter reading and time.
  - Set engine controls.
  - Switch on ignition.
  - Prime 3 pumps if a cold start.
  - Pull the starter.
  - Have you checked the weather, the traffic?
  - HAVE FUN!!!

## FUEL SYSTEM OPERATIONS

### SIGHT GAUGE

The sight type fuel gauge that is standard with this model has been reported to give erroneous readings. The sight gauge can indicate full fuel when the actual fuel level can be near empty. The cause of such incorrect readings may be the result of an improper installation. Please check your vent and sight gauge for kinks and proper line routing. Most importantly, do not take the readings for granted. Always time your fuel burns. Visually check your fuel by looking inside the fuel tank from the filler neck before each flight.

## SIPHONING

When the fuel system is not filled to the point it is touching the bottom of the filler neck down to 1/2" below, it is possible for fuel to siphon. This is caused by a differential in pressure between tanks, uncoordinated flight, or turbulence. One tank will push fuel into the other. Once the tank overflows out of the vent, siphoning will start. This will continue until most of the fuel is out of the OPPOSITE TANK. The way to break the siphon is to stop the flow from the withdraws on the non-siphoning tank. Since the chances of siphon are not constant, a handy way to shut off the fuel from the opposite tank is to clamp the lines with a needle nose vice grip. If you use the needle vise grips, slip a short segment of fuel line over each jaw to prevent the grips from cutting into the fuel line. This sounds like a fairly crude way of shutting off fuel, but it is effective. If you desire a more permanent method, you may want to install valves to shut off the fuel from each tank. If you choose to go this way, please follow this operational procedure. Normal Operations: Both valves on. If siphoning occurs, shut off the opposite tank.

## ENGINE OPERATIONS

Provided with the aircraft is an engine manual authorized by the engine distributor. This is a well written manual explaining many specifics for continued safe and reliable operation of your engine. We urge you to read and fully understand this manual. In addition, please find the data below helpful in obtaining the most out of your aircraft.

### STARTING

Position the aircraft into the wind and check the main wheels to prevent rolling. To maneuver the aircraft into position lift the tail at the strut connect points. Avoid lifting at the tips of the control surfaces. CAUTION: Winds above 15 mph may cause the aircraft to lift off when empty. Have an assistant sit in the plane or help hold it down at the wing strut connect points. Never hold it down at the wing strut connect points. Never hold a strut in the middle!

It is best to start the plane from inside the cockpit. The S-6ES Coyote II can be entered easily by first sitting on the seat, then pulling up your knees and rotating into position.

Drain the fuel sump under the left hand seat. Prime (if first starting or if it's been 30 minutes since the last start) 3 pumps. Close the throttle (pull back to close). Flip the ignition switch up for on. Move the control stick to the left. Grab the start handle and pull briskly. Several pulls may be needed. Be sure the ignition is on (switch up). Let it idle a moment and then advance the throttle slowly. NOTE: After the engine warms up, 2 minutes, close the throttle. It should idle at 2,000 RPM. If not, refer to the engine manual for details on setting the idle. If you encounter starting difficulties refer to the engine manual for probable causes and solutions. CAUTION: In cold weather allow at least a 2 minute warm up before applying take-off power.

Check the throttle action. There should be no sluggish response from mid range to the top end. Do not rapidly pump the throttle. This is not a motorcycle! It is an airplane with a big fly wheel, the propeller. Jockeying the throttle will only accelerate wear on the engine and make its reliability questionable. Be smooth with the throttle and it will respond when you need it!!!

### REASONS FOR POWER LOSS

Never take off if a PLUG IS FOULED. This will be indicated by sluggish throttle and lack of RPM and rough running. Two strokes do not unfoul their plugs. They only get worse. So flying to "clear it out" may result in a power loss and a forced landing.

**WORN PLUG**

Again the throttle and RPM are not normal. Replace with a fresh properly gapped plug. Plugs should be replaced every 25 hours.

**CLOGGED AIR FILTER**

Spit back, the tendency at low RPM's for the engine to throw fuel out of the carb and into the air filter causes the engine oil to eventually clog the filter. The situation worsens rapidly because the more clogged the air filter becomes the more fuel that spits back. This can occur on a Coyote II about every 40 hours. Therefore, it is recommended to clean and re-oil (with the air filter only) the filter on a periodic basis. Soak the filter in clean, raw gas. Then rinse and let dry thoroughly. Re-oil when dry as per the air filter oil instruction. **NOTE:** The filter oil is K&N brand and is available at most motorcycle shops.

**OBTAINING MORE RPM**

Due to variations in propellers and engines you may not obtain proper T.O. RPM's. We recommend at least 6000 plus RPM's. If this is not the case a simple modification to the propeller can be made which will usually gain 300 RPM. Cut the tip profile to the shape shown in the tip modification pattern.

**INSPECTION OF ENGINE SYSTEMS****Cowling**

- Check for: Missing screws
- Loose bolts
- Cracked glass
- Cracked mating flange
- General condition

**Remove the Cowling and inspect the following:**

- Check for: Cracked welds
- Missing or bent bolts and loose nuts
- Elongated holes or cracks at mount plates
- Deteriorated rubber mounts
- General condition

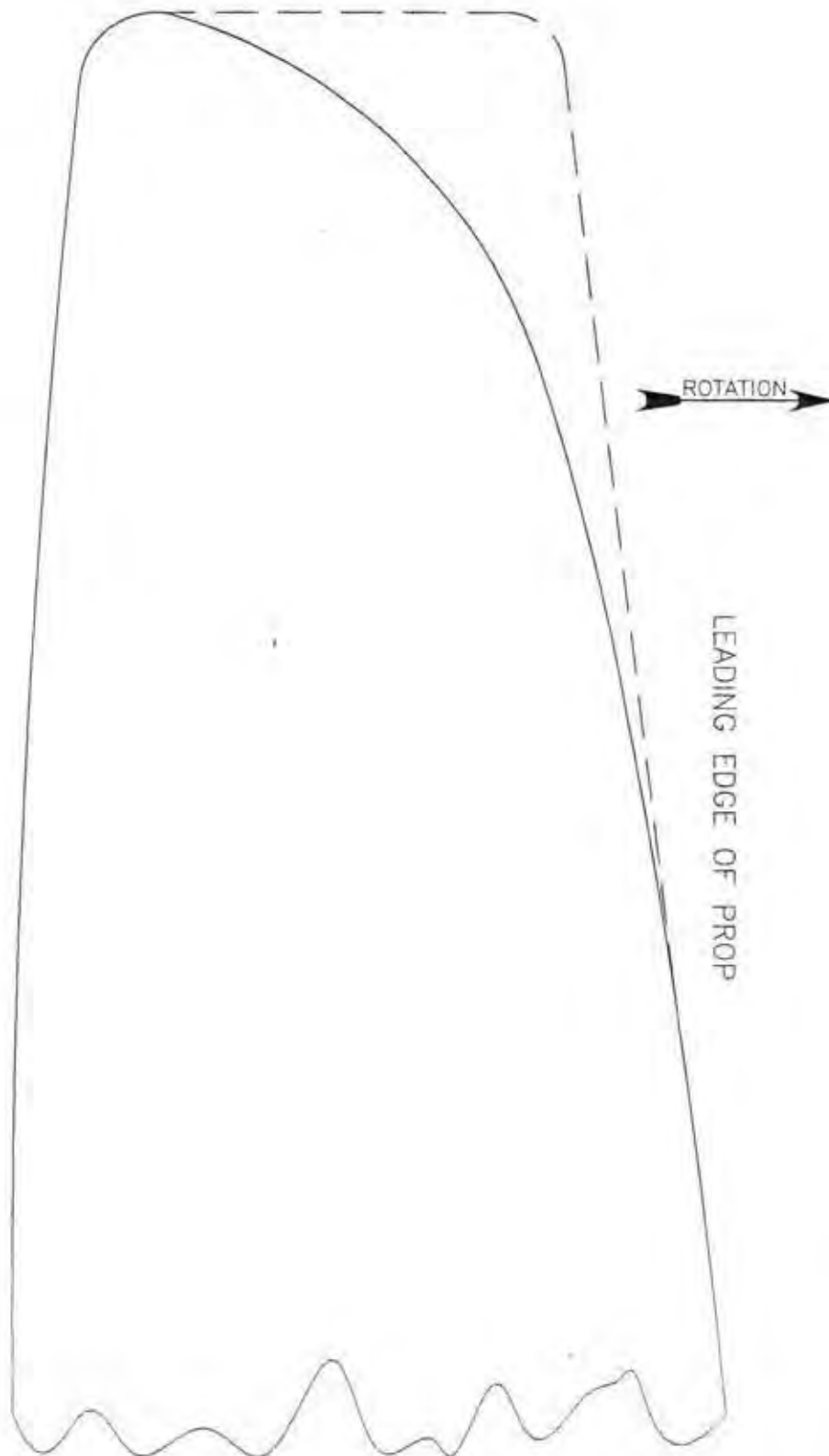
**Carburetor and Throttle Quad:**

- Check for: Position (90 degrees to cylinder)
- Clamp tightness
- Throttle and Choke cable wear
- Smooth Throttle and Choke action
- Loose or missing bolts or screws
- General condition

**Muffler**

- Check for: Spring tension
- Cracks in manifold and welds
- Worn or broken hanger bracket
- Clearance from airframe and gear cables
- General condition

CUT AWAY AND RE-PROFILE  
AIRFOIL. THIS MODIFICATION  
CAN YIELD AS MUCH AS A 300  
RPM INCREASE.



MD618



**Fuel System:**

- Check for: Leakage anywhere in the system
  - Cracked, worn or ruptured fuel lines
  - Firm connections
  - Fuel pump integrity
  - Leaky primer pump/lines
  - Fuel tank integrity
  - Fuel filter clogs
  - General condition

## S-6ES & S-6XL COYOTE II OPERATIONS

**PRE-FLIGHT:** Refer to the pre-flight section of this manual.

**STARTING:** Refer to the engine operations section of this manual.

**TAXIING:** Taxiing the Coyote II is easy even in a 25 mph wind. The direct linkage to the steerable nosewheel enhances the ground handling making tight turns a snap.

If the wind is strong learn to use it to your advantage. Taxiing into the wind with forward stick will increase nosewheel traction and enhance steering. Taxi slow or you may start flying.

During downwind taxiing hold the stick neutral. Make small steering corrections and taxi slow.

In the hands of a skillful pilot the Coyote II can taxi in winds up to 25 mph. Operations in 35 mph winds have been conducted with two on board.

Flying in high winds above 35 mph is also possible. However, this capacity should be used only as a means to get out of a situation not to invite one.

**TAKE-OFFS:** The Coyote II becomes airborne easily with rotation at 35 mph (average gross weight 800 lbs). Naturally rotation will vary with the gross weight. Normal, short field and soft field take-offs are possible using conventional techniques.

**LANDINGS:** Special attention to airspeed on approach is vital to making smooth landings. As with any aircraft too little speed and power and the Coyote II will sink out of the sky. The sink can be controlled and must be controlled during a deadstick landing. Naturally, to arrest sink, the pilot flares to land. The point at which to flare is critical.

A good way to land the first time is to plant the mains first. Get established over the runway at 50 mph plus about 2 feet off the ground. Once things are stabilized, wings level, pitch smoothed out and flying straight down the runway, slowly reduce the power while gradually easing back on the stick, letting the plane settle onto the runway. **IMPORTANT:** Hold the nose off during landing. Avoid letting it drop once the mains are on. Swerving side to side may result when the nosewheel is dropped on in cross winds or high speeds. This will familiarize you with the flare point.

Deadstick landings are done safely and smoothest if at least 50 to 60 mph can be maintained on approach. This gives you extra inertia and float, provided you flare at the right time. Lowering the flaps 2 notches in ground effect can give an extra boost to stretch the glide.

**AIRWORK:** The Coyote II will perform like a conventional plane with the exception of a more rapid speed decay when power is reduced. The Coyote II will tell you what it needs...if you are listening. Flight characteristics of the Coyote II are nearly identical to planes like the J-3 Cubs, Super Cubs, and T-Craft, etc. Although all have their distinguishing manners none do anything strange or unpredictable.

**STALLS:** Stalls have a warning buffet due to turbulent air from the wing root flowing over the elevator. The stall occurs with a definite break. Rudder may be needed to hold the wings level due to the "P" factor. Recovery is instant with the release of back pressure. Turning, accelerated power on and power off stalls all demonstrate the slight buffet and quick recovery.

**TURNS:** The Coyote II banks quite easily with a minimum of adverse yaw. Lead into turns using a little rudder. Avoid steep banks until comfortable with the ship. Due to the quick turn rate, steep 360 degrees or 720 degree turns can be disorientating. Attempt these only after you are familiar with the airplane.

**FLYING WITH THE DOORS OPEN OR REMOVED:** The S-6ES can be flown with the doors open up to and including 65 mph. The S-6ES doors should not be opened at airspeeds above 65 mph. The S-6ES can be flown with (1) or both doors removed up to 65 mph. A loss in L & D, climb and cruise speed is to be expected with the doors open or off operations.

### **APPROVED MANEUVERS:**

Stalls, all types except Whip Stalls  
 Falling Leaf at low power settings (below 4,000 RPM)  
 Chandelles  
 Lazy Eights  
 Spins up to 3 turns at low power settings and without flaps only!

**ALL AEROBATIC MANEUVERS EXCEPT THOSE APPROVED ARE PROHIBITED**

### **ASI MARKINGS**

Paint the appropriated colored arcs on your ASI for the following speeds (in mph):

	STANDARD WING	116 WING	
White Arc	36* to 65	45* to 80	(Stall to Maximum flap extension speed) (* Determine actual with flight testing)
Green Arc	43* to 85	50* to 117	
Yellow Arc	106 to 120	117 to 130	
Red Line	120	130	

### **SPECIAL OPERATIONAL CONSIDERATIONS**

**POSITION IGNITION SWITCH** Up is for on, down is for off.

**THE FUEL CAP MAY POP OPEN** During unusual flight maneuvers such as abrupt negative loads. Avoid free fall 0 G's flight.

**FLIGHT MANEUVERS THAT INDUCE NEGATIVE LOAD** may cause fuel leakage through the vent cap and momentary fuel starvation due to the negative G's on the float style carburetor. Avoid low lever abrupt pull ups followed by an abrupt dive.

**WARNING: SECURE ANY FORM OF CARGO** and be careful of clothing articles falling into any part of the aircraft's working mechanisms. Jamming of the controls may result. Always wear the safety belt and shoulder harness to be sure these also do not interfere with the controls.

**CHECK THE CARBURETOR** during pre-flight for clamp security. After a few hours the fuel/oil mix will lubricate the rubber intake manifold. It is then possible for the carburetor to rotate into a position that may cause fuel overflow and possible fuel starvation. Remove, clean and reclamp.

**FUEL SHUT-OFF VALVE** must be on for flight. Always check it. There is enough fuel retained in the system past the valve to permit a take-off followed by a deadstick landing!

**SLOW TO 70 MPH** in severe turbulence. **AVOID** descending at high rates of speed from high altitudes into unknown conditions. A shear layer may be present at a lower level causing turbulence. Remember, high speeds and severe turbulence may accelerate airframe fatigue and shorten your aircraft's effective service life.

#### **AIRSPEEDS:**

- Maximum turbulent air penetration speed is 80 mph.
- Maximum flap extension speed is 65 mph.  
(55 mph for 6-6EC version)
- Maximum door opening speed is 75 mph.

**KEEP ALL CONTROL** surface hinge points and other moving parts well oiled.

### **SPECIAL SECTION ON FLAP OPERATIONS**

#### **IN GENERAL**

The flap equipped Coyote II has a wider speed envelope but this is only realized through proper flap usage. Please take the time to become thoroughly familiar with the aircraft and procedures before attempting any maximum performances, take-offs or landings. The aircraft functions well without using flaps only take-off/landing distances are longer and speeds are higher. Pay close attention to the recommended flight speeds called out in this section.

The first notch of flaps is 11 degrees used to moderately shorten take-off rolls. The max flap extension speed is 65 mph. Although it is allowable to extend to full flaps at 65 mph, it is actually better technique to extend a notch at a time. **EXAMPLE:** 65 mph-1st notch, 55 mph-2nd notch, 45 mph-3rd notch. You'll find this gives you much smoother approaches with less flap lever pressure. For your reference 1st notch/11 degrees, 2nd notch/30 degrees, 3rd notch/43 degrees.

The second flap setting is used again to shorten take-offs and to smoothly decelerate to approach speed. The third notch of flaps is going to yield the shortest take-off with the least distance over a fifty foot obstacle. Also this setting allows steeper, slower approaches. Typically a 45 mph approach speed in a 20 degree nose low attitude is desired. **CAUTION:** It is very easy to extend 65 mph, the maximum flap extension (vfe) speed during such approaches...be wary of this.

#### **MAX PERFORMANCE TAKE-OFFS**

Prior to executing a max performance take-off it is recommended to have performed several take-off and landings with no flaps, 1 notch and 2 notches. **PROCEDURE:** Flaps 43 degrees, brakes on full, briskly apply full power holding stick slightly back to raise the nose. Ease back pressure once breaking ground

as needed to maintain 40 to 45 mph (best angle of climb speed) to 50 ft., then start slowly easing off the flaps and maintain 55 mph for best rate of climb speed. Set power as needed. **CAUTION:** Do not "dump" the flaps when retracting...always bleed them off slowly and let the airspeed increase.

This procedure has proved to yield the shortest possible take-off. Also, it is recommended for soft fields. The technique is not fool proof, however, and requires a fair amount of piloting skill.

### LANDING WITH FLAPS

Maintain at least 45 to 50 mph with full flaps and a constant glide slope in a nose low attitude. Fly down to the runway, then level off at 2 to 3 feet to start the flair. **CAUTION:** Low power and a nose high point attitude during the glide slope is to be avoided with or without full flaps. The aircraft may develop high sink and not recover.

POWER OFF STALLS	BANK		
	0	30	60
FLAPS			
0	33	39	45
11	34	38	44
30	32	36	42
43	27	35	40

POWER ON STALLS				
	0	22	25	27
FLAPS				
0	22	25	27	
11	20	23	26	
30	20	23	24	
43	20	23	24	

Performance based on standard day gross weight of 875 lbs.

**CAUTION:** Inspect flap lever catches for wear every 100 hours. Keep roller lubricated.

**PROHIBITED:** Spins with flaps extended any degree but 0.

Avoid prolonged flight at high power settings and slow speeds. This flight mode causes violent, turbulent airflow over the tail with associated "tail buffet". This can be felt in a stick shake. This is a warning of an impending stall and to decrease the angle of attack and increase airspeed.

### TRAILERING & TOWING PRECAUTIONS

When towing long distances on an open trailer remove the tail surfaces. Highway speeds and gust loads can cause undue loads on the tail group.

Make certain the wings and tail components are secure and will not catch the wind underneath. Tie down the wing at the ends about 2 ft. in and in the middle.

**CAUTION:** If you must tow tail first with the tail group assembled lock the rudder and the elevators with a control lock. Haul like this only in moderate surface winds and drive below 35 mph. This method works fine for a few miles like to the flying site, but is not suited for long hauls.

### DISASSEMBLY FOR TRANSPORT

The distance, terrain, weather and type of trailer will determine how much disassembly you must do to transport your Coyote II. Usually we simply remove the wings and hang them on the wall of an enclosed trailer.

Naturally, disassembly is reverse of the assembly with the exception of those items you decide to leave assembled (tail group, etc.).

**CAUTION:** Be **VERY** careful when disassembling and transporting your craft not to gouge, scratch or bend the wing struts. The bolts that retain the jury struts can gouge the struts if no packing is used between them. Avoid any method of dismantling or packing that can cause damage to any part.

### MAINTENANCE

**COVERING:** The Coyote II is covered with a 3.9 oz. per square Dacron Sailcloth. This dyed to color material will last several years if the plane is stored out of direct sunlight while not in use. Ultraviolet light is the main reason for loss of skin strength. The tell tale signs of an aging skin are;

1. Color fading.
2. Embrittlement
3. Easily torn with rips likely to enlarge.

To preserve your covering there is now a clear coating (Stits Aerothane) that can be sprayed on. The effectiveness in life span extension is considerable. However, the best preservative is indoor storage out of weather and sunlight.

**CORROSION and WASHING YOUR PLANE:** Using the garden hose to wash the outside of your plane may seem like a great idea, however this is a practice avoided at the factory. We simply never let the plane get to the point it needs hosing. Instead, the exterior of the plane is cleaned using a product called Brilliance. This mild cleaner works great on all surfaces including the Lexan. For the oil or exhaust stains, we use 409 or Fantastic. These clean very effectively without apparent damage to the paint.

If your plane is open air like an Airaile or Stinger and you do use a hose to wash it down, you may be causing a future corrosion problem. In the case of any open cockpit plane with the tail sitting low, it is possible for water to collect inside the elevator push pull tube. This will rust away the elevator yoke and corrode the push pull tube also.

Even leaving the plane in the rain can allow moisture to collect in the elevator yoke. Please avoid the practice of spraying water into the cockpit area of your plane, open cockpit or not, this is a practice that will lead to corrosion problems and part replacement.

If you suspect your aircraft of corrosion problems, inspect all areas where water may collect, such as the elevator yoke area.

**IMPORTANT:** If you conduct flight operations near or on salt water such as landing on beaches or float activity a thorough fresh water washing is a must after each final flight of the day. This should be done as soon after the flight as possible. Saltwater can be the cause of serious corrosion problems for key structural elements. Internal rinsing of spars, struts and fuselage members with fresh water is required if the plane has been excessively wetted or submerged in salt water. During cleaning of any type inspect the craft for signs of corrosion and any other abnormalities.

### **AIRFRAME UP KEEP**

The aluminum and steel structure is designed to last for many years. However, constant abuse through hard landings and high speed flight in rough air could fatigue key structural elements. To inspect the airframe, look for cracks, hole elongation, flecking of anodizing (indicating bends or overloads), bent, dented or corroded tubing and any signs of misalignment or distortion. Consult your dealer or the factory if your inspection reveals trouble or in the event of accidental damage beyond your capabilities or repair.

## **GENERAL DESCRIPTION AND FLIGHT PROPERTIES**

**DESCRIPTION:** The Coyote II is a high wing, tractor, mono plane with tricycle landing gear. It is strut braced with aluminum tubing and welded 4130 steel construction. It has Dacron sailcloth pull on covers.

The design features a roll cage construction, an enclosed cabin when side doors are installed, shock absorbing "Cub" type gear, steerable nosewheel, ailerons and flaps.

**FLIGHT PROPERTIES:** The Coyote II flight properties are conventional in respect to general aviation aircraft in the areas of control and response, with the exception of a greater speed decay rate due to its light but "large" nature. This is typical of any lightweight plane, where little kinetic energy is to be had.

**STALLS:** Are preceded by an easily distinguishable buffet caused by the turbulence over the horizontal stabilizer from the inboard wing stall. During this root stall, there is a sufficient lift and control to maintain flight. Once the entire wing stalls the nose falls through very slightly and a high sink rate develops (approximately 1,000 to 1,500 fpm). The craft can be held wings level with the rudder. **NOTE:** During this "falling leaf" condition we assume full up elevator is applied.) The plane may take a couple of gentle 10 degree pitch ups if the deep stall was entered from an exceptionally nose high attitude. Nonetheless, it will rapidly settle into a slightly nose high mush until back pressure is released.

If, during a deep stall (falling leaf) the pilot's feet are removed from the rudder pedals, the Coyote II will begin to dip each wing alternately until finally making a gentle spiral to the right or left. (**NOTE:** This is not a spin!) At this point it could be argued that it is spinning. However, rotation is not through the plane's center mass. Instead, it is as if it were riding down the sides of a vertical cylinder. Thus, I maintain it is a spiral. To further support this, the spin properties are very conventional. Entry requires full deflection of elevator and rudder and must be held in full deflection.

The spin's rotation is approximately 80 degrees nose down with rotation through the center mass, almost through the aircraft centerline (10 degrees from it). Rotation speed is 3 seconds per turn. This is reached after the second rotation and will not increase. Flight tests show no rotation increase even after 10 turn spins. Sink rates average 1500 to 2000 fpm, with 200 to 400 feet lost per turn depending on density altitude.

This spiral and spin difference is easily recognized as well as controlled. Stall and spin testing in all configurations has been done with no unusual characteristics revealed.

In conclusion, the Coyote II will spin only if fully stalled and ruddered. Recovery can be effected in 1/4 turn using opposite control or in a 1/4 turn by neutralizing. Given the pronounced stall warning with quick recovery rates from either stalls or spins, the Coyote II can be flown safely and predictably by the low time pilot.

As a result of the excellent stall warning and positive control ability, the Coyote II can be used as a S.T.O.L. aircraft. With the 47 hp engine, take offs can be as short as 150 feet in no wind. Angle of climb can be 25 degrees to 35 degrees at 40 mph, 600 fpm and full flaps. (R.O.C. increase with retraction of flaps.)

Testing has shown complete control and can be maintained during S.T.O.L. take offs and landings even when "hanging it on the prop". In this mode an engine failure could result in a stall since airspeeds are in the 30 mph range. Therefore, it should be used by the experienced and only when needed, for example, when landing on an exceptionally short runway (800 feet with 50 foot or higher obstacles on each end).

**TAKE-OFFS:** Begin with a small amount of left rudder to counteract the P factor. This diminishes once the speed is up. Rotation generally occurs at 35 mph with climb out at 55 to 60 mph.

Cruise configurations will vary with loading, an average payload being 400 lbs. This average condition with the 47 hp engine yields a 3.75 gallons per hour fuel consumption at 78 mph and 6000 rpm.

### KEEPING YOUR ROTAX ENGINE CARBON FREE

The Rotax manual as well as the following information outlines some excellent procedures to assure reliable operations. However, in the real world the method suggested for carbon removal is only a half-way measure. True removing the cylinder heads and scraping the dome and piston top will prevent carbon from fouling the plugs. But we go one step further by removing the cylinders and then the pistons. Why? To clean the ring grooves. Yes, for the first 200 hours it is **VERY** important to clean the rings and pistons every 50 hours. Sounds tough but it is not bad if you are careful (and easier than fixing airframes). Use an aluminum scraper and be careful when removing the rings not to bend them or get them mixed up. Do one piston and reassemble it to the rod. **THEN** do the other. You will be surprised at the carbon build! Now if you do not see stuck rings or carbon **DO NOT** clean it! You are a lucky one, but do inspect it regardless. After 200 hours you may opt to go to 65 hours instead of 50. You will know by the condition of the engine from previous inspections. A ring stuck by carbon build can cause seizures because of blow by and localized hot spots. The piston skirt heats and swells until it sticks. Carbon free rings will assure this potential failure is eliminated.

## READY TO FLY CHECKLIST

### FIREWALL FORWARD:

1. All mount bolts tight?
2. Gear Box serviced and safety wired?
3. Muffler springs safety wired and siliconed?
4. Muffler extension installed?
5. Overflow bottle installed & plumbed?
6. Radiator hose clamps tight?
7. High pressure cap (15-18 lbs) installed?
8. Radiator drain safetied?
9. All electrical connections made and heat shrunk?
10. Oil bottle installed & plumbed?
11. Carbs and air cleaners on & plumbed?
12. Plugs gapped & torqued?
13. Throttle & oiler cables set up properly?
14. Fuel pump on & plumbed?
15. Nose wheel inflated & collar pinned?

### FIREWALL AFT:

1. Windshield Z's installed?
2. Center brace in place?
3. Steer horn bolt tight?
4. Steer linkage adjusted & loctite?
5. Brakes routed correctly?
6. Rudder cables tightly bolted?
7. All instruments installed & properly wired?
8. Primer installed & safety wired?
9. Starter handle hook installed (only if not electric start)?
10. Starter switch installed (for electric start)?
11. Wire cover installed?
12. Lower panel cover installed?



## CHECKING STATIC RPM

Prior to the first flight, determine the engine's static RPM; this is the speed it develops when stationary and fully throttled. An acceptable static RPM indicates that the engine is operating at or near full potential and should not over-speed during the first flight.

First, calibrate the engine tachometer to make certain it's accurate. Determine the propeller's RPM with a *light tach* (a hand-held device which measures propeller rotation with infrared pulses) and compare the reading to the tachometer's, taking into account the engine's gear reduction ratio. The tachometer supplied with your RANS kit is equipped with a calibration knob; refer to the manufacturer's instructions.

Once satisfied with the tachometer, run the engine with the throttle fully open; be certain the tail is tied down and the main gear is chocked. For the two-stroke Rotax 503 and 582, acceptable static RPM is usually about 6000 to 6200; for the four-stroke 912, it's usually 5000 to 5200. (A number of factors influence this, including the number of propeller blades, their length and pitch.) Ideal static RPM would render an *in-flight* RPM just below red line with the throttle fully open at sea level.

A high static RPM may indicate that the propeller is pitched too finely (the blades take too small a bite of air). This prevents the propeller from performing most efficiently and may allow the engine speed to exceed red line in flight. If the blades are adjustable, increase pitch; refer to the manufacturer's instructions. If the blades are fixed, contact the manufacturer.

A low static RPM may indicate that the propeller is pitched too coarsely (the blades take too large a bite). This also prevents the propeller from performing most efficiently and induces excessive load on the engine. If the blades are adjustable, decrease pitch; if fixed, contact the manufacturer. If finer pitch does not raise maximum engine speed to an acceptable RPM, another problem may be indicated.

**WARNING: Attempting flight with too much or too little propeller pitch may have severe consequences. Conduct flights only with sufficient power output!**

Knowing the ideal static RPM allows you to check the health of the engine during a full-throttle run-up prior to takeoff. Once you've become familiar with the in-flight performance of the engine and have adjusted the propeller, you'll know better what the tachometer should indicate during run-up.

## CREATING A PILOT OPERATING HANDBOOK

Most pilots are accustomed to flying light planes with comprehensive pilot operating handbooks. This is a result of the standardization required by FAA certification, the fruit of which is fleets of identical aircraft for which specific checklists, procedures and performance figures may be published.

This section includes much information on the operation, limitations and performance of RANS aircraft; however, the nature of kit-built aircraft makes it impossible to publish *specific* checklists and procedures applicable to *all* examples of a particular model. This is because the builder, as manufacturer of the aircraft, has the freedom to assemble, equip and modify his machine as he wishes. The result is fleets of aircraft that share the same name and designation, but vary somewhat in operation and performance.

The builder should consider carefully all aspects of the engine, airframe and equipment when developing checklists and procedures for his plane. For example, he might begin the preflight inspection by opening the cabin and checking that the magnetos are off; this would ensure the engine cannot start if the propeller were moved. With the cabin open, he also might drain fuel from the sump, allowing any water trapped in the system to escape. He then might begin a walk-around, moving about the ship in a logical,

straightforward manner, checking the presence, security and condition of hardware and components.

With the walk-around completed, he might seat himself in the aircraft and consider the checks necessary for a safe and mechanically sound engine start. This will depend largely on the specifics of the engine, fuel, ignition and electrical systems he has installed. Again, a straightforward, logically-flowing checklist should be developed that addresses the particulars of his machine.

The same care should go into development of a pre-takeoff checklist. Of particular importance is a proper engine run-up to check the health of the power plant. An essential checklist item often given short shrift is that of free and correct movement of control surfaces; this is particularly important for aircraft that fold or disassemble.

Considerable forethought should be given to potential emergencies. What steps should be taken to deal with balked landings, engine failures or fires? How might these steps vary according to the phase and conditions of flight? Consideration of contingencies now is likely to mean faster, more appropriate reaction to urgent or emergency situations, should they arise.

Since each kit-built aircraft is unique, each builder should expect his aircraft's performance to be unique. The prudent builder will determine carefully the weight and balance parameters of his plane before its first flight. He'll familiarize himself with its flying characteristics during the flight test phase, cautiously exploring its capabilities and limitations while heeding the designer's words of advice. The U. S. Government, the Experimental Aircraft Association and other publishers offer a wealth of information on flight preparation and testing. As a first step, the builder might refer to the FAA's AC-90-89, "Amateur-Built Aircraft Flight Testing Handbook."

By applying suitable checklists and procedures to his plane and operating it within reasonable limits, the builder helps ensure his safety as well as the reliability and longevity of his airframe, power plant and components.

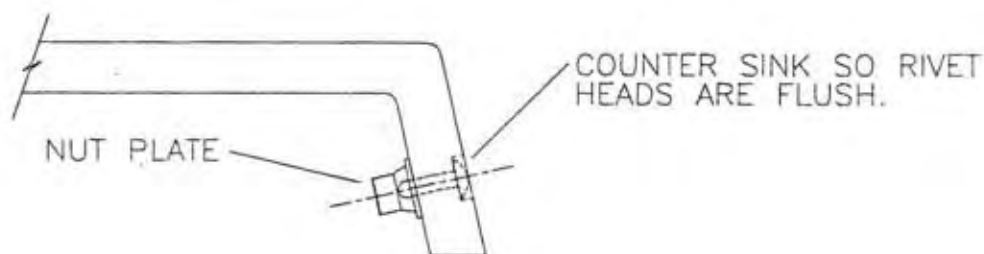
## S-6ES & S-6XL COYOTE II 9" SPINNER ASSEMBLY

Refer to the cowling parts page for selection of components and hardware.

1. The spinner and backing plate comes ready to trim and drill. Observe the scribe lines and trim to these lines. Be especially careful to trim and sand the edges evenly. Check for trueness by setting on a flat surface. Drill the backing plates center with a 1" hole saw. It may need a little sanding to fit over the prop flange. Test fit as you go. Wet sand with 350 grit paper.
2. Insert the 1" aluminum tube scrap into the prop then install on the backing plate. Prop **MUST** be flat against the plate. Drill (6) 1/4" holes through the backing plate using the prop as a drill guide. **IMPORTANT:** After drilling the first hole, insert a 1/4" bolt to prevent shifting. **NOTE:** The slight dip in the plate is used to "pre-load" the plate against the prop.
3. Set the prop and backing plate on a flat surface. **NOTE:** To assure accuracy bolt the backing plate to the prop with (3) bolts. (AN4-32A will work if washers are used.)
4. Set the spinner on the prop/backing plate assembly. Set it so an even amount of space is on either side of the prop openings. Mark the hole locations on the spinner's perimeter every 3" with (5) screws evenly spaced on each side. Drill through at these locations with a #30 bit, cleco as you go. Be sure the spinner and backing plate are flat against the table.
5. Disassemble and drill out the #30 holes to #11. Install the nut plates using a bolt to hold the nut plate in place and drilling from the inside. The rivets' heads need to be "counter sunk", do so by drilling a slight depression with a #11 bit. See **Figure 025-05**. Set the rivets by resting the head against a vise and tapping the driven end with a small hammer and check for tightness. The nut plates must be snug.

**NOTE:** Some spinner kits may use 3/32" aluminum pop rivets.

**FIGURE 025-05**



MD1372

6. Sand the spinner with 350 wet/dry paper. Paint to match aircraft.
7. The spinner and prop should be balanced and no adjustment required. However, the ultimate test is in the running. If you have a lot of vibration it could be caused by out of balance or misalignment. Use a good prop balancer such as the one LEAF sells. (Available through them or us for \$20.00.) Check both the prop and the backing plate, if the misalignment is not correctable then a new spinner may be required. Misalignment occurs through improper trimming of the parts. A slight amount of "wobble" is acceptable and may disappear at higher RPM's. Always pre-flight your spinner. Although our tests shows great promise it is still an experiment so be watching for cracks. Every 50 hours remove the spinner and prop to inspect the backing plate where it contacts the prop flange.

## S-6ES & S-6XL COYOTE II BAGGAGE COMPARTMENT ASSEMBLY

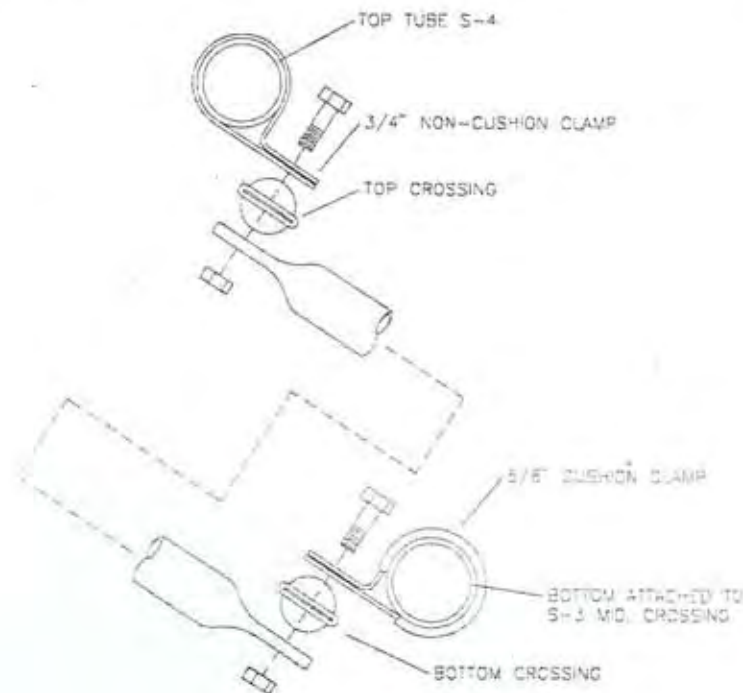
1. Select all the parts depicted in the parts drawing.
2. Lace the baggage bag ends through the side braces. Bolt the side braces in place to the S-3 top and the gear truss top crossing tubes as shown in the parts drawing.
3. Slip the top and bottom braces into the baggage bag's long pockets and bolt them to the side braces via 1/2" tube clamps.
4. Slip the bottom lexan into the bags floor pocket. (Peel the paper off if you like.)
5. Adjust the cross braces so they just touch the guard and allow the seat to move into its rear most position.
6. Maximum baggage allowable is 50 pounds. **CAUTION:** Do not load cargo that exceeds the floor's bearing capability. Avoid small heavy objects. Always use the flap and straps when hauling baggage to retain the load.

## S-6ES OPTIONAL AFT BAGGAGE COMPARTMENT ASSEMBLY

**IMPORTANT:** The baggage compartment can only be installed prior to covering, but with the tailcone assembly complete.

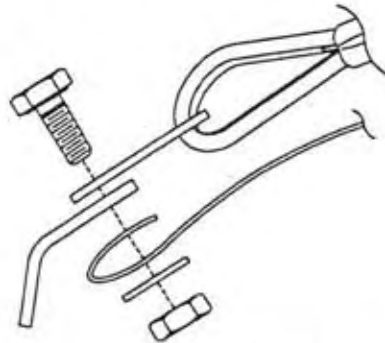
1. Select the parts depicted in the parts drawing.
2. Drill each end of each baggage compartment support tube on center 1/4" in. Place the proper tube in the corresponding fabric pocket on the sides of the baggage compartment.
3. Slip the 3/4" non-cushioned clamps over the S-4 Top Crossing Tube and bolt the tubes as shown in **Figure 025A-03**. Slip the 5/8" cushioned clamps over the S-3 Mid Crossing Tube. Assemble the lower tubes in the same manner. The baggage compartment is shaped to fit into the tailcone, so any incorrect assembly should be obvious.

**FIGURE 025A-03**



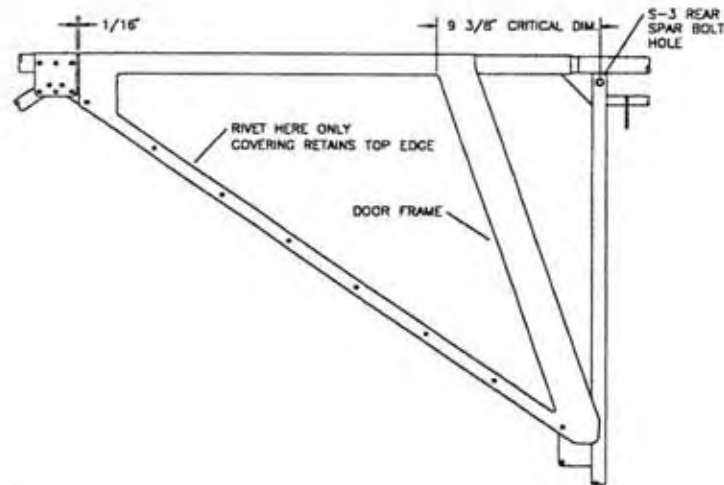
MO0251

4. With the baggage compartment in place, attach the strap to the lower station 4 cable attachment as shown in **Figure 025A-4**. Fold over the strap for extra strength. Use a soldering iron to melt a hole into the strap. Lace the strap through the buckle and pull it tight. If the baggage compartment is properly installed, all surfaces should be flat and tight. Lace the cargo flap straps to secure.

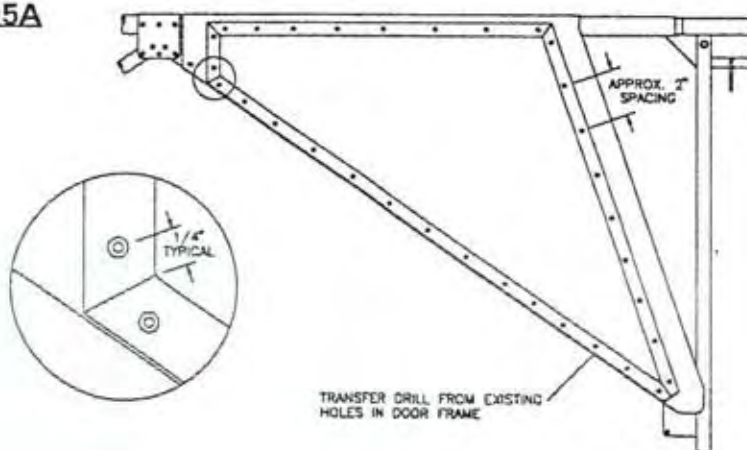
**FIGURE 025A-04**

MD1844

5. Place the baggage door frame on the aircraft's right side. The frame should be self locating, however, check the location as shown in **Figure 025A-05**. With the door frame in its correct location, layout, cut, miter and pre-drill retainer strips (from raw stock supplied) as shown in **Figure 025A-05A**. **IMPORTANT:** Do not rivet until covered. Rivet these strips after covering to secure fabric. **HINT:** Paint strips and baggage door to match fabric. Call factory for paint match numbers if desired.

**FIGURE 025A-05**

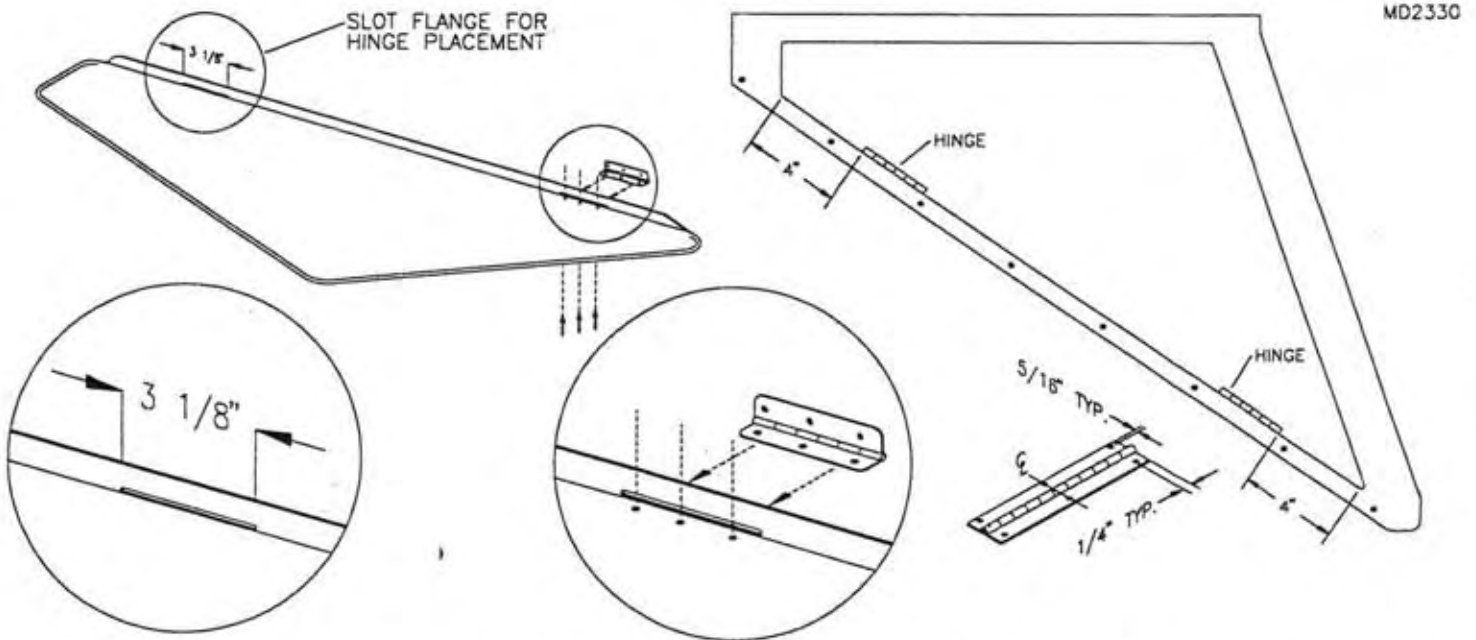
MD1844

**FIGURE 025A-05A**

MD1844

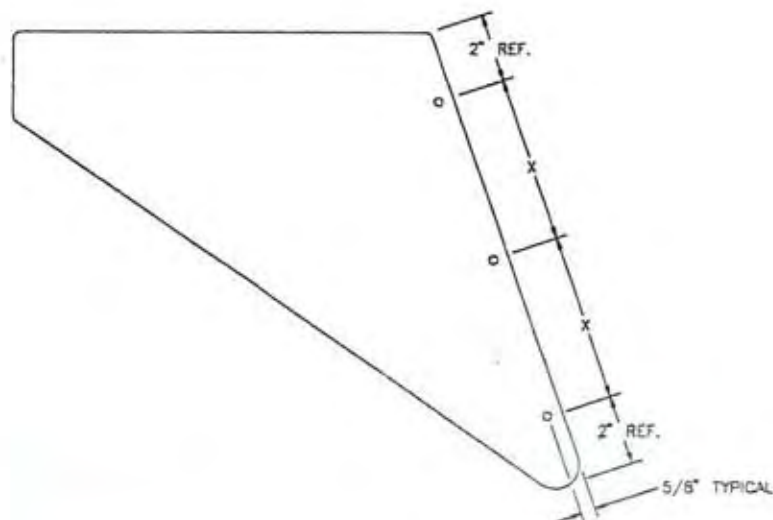
6. Mark the location of the two hinges 4" in from each corner of the baggage compartment frame as per Figure 025A-06. Transfer the hinge locations from the baggage compartment frame to the door. Slot the flange of the door as shown to allow for proper hinge placement. The slot can be easily made by drilling a series of #30 holes; then use a small round file or a hack saw to connect and smooth the slot (A Dremel tool is helpful here). Drill three holes per hinge. Hint: It is a good idea to tape the hinges and door in place and check operation before drilling any holes. Final rivet the hinges to the door frame after covering and painting. Make sure to overhang the hinges off of the frame to allow proper door operation.

**FIGURE 025A-06**



7. Locate the 1/4" turn thumb screws as shown in Figure 025A-07. See cowling for details on installing 1/4" turn fasteners.

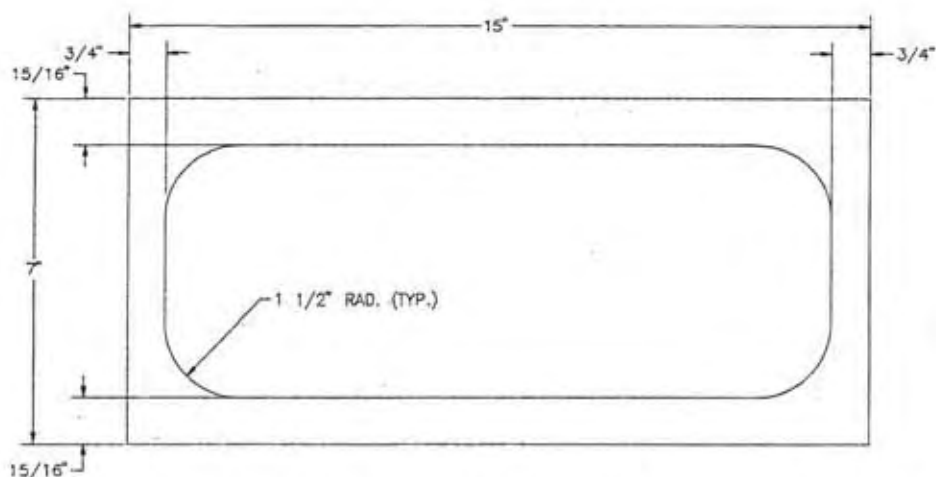
**FIGURE 025A-07**



## S-6ES & S-6XL COYOTE II NOSE WHEEL PANT INSTALLATION

1. Fabricate the illustrated template shown in Figure 025C-01 below from a piece of cardboard or poster board.

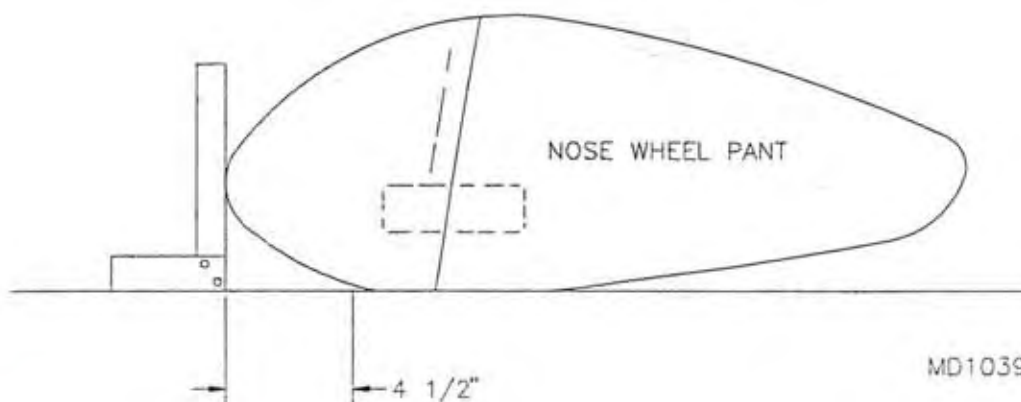
**FIGURE 025C-01**



MD1039

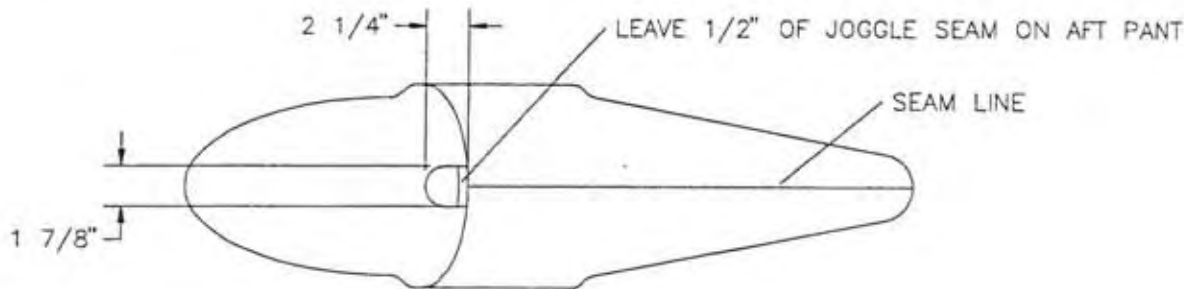
2. Trim both the FWD and AFT pieces of the nose wheel pant down to their gel coat line along the joggle and overlap seam.
3. Slip the AFT section of the wheel pant inside the forward section and tape together with wide masking tape. Use this template to mark and trim the wheel hole in the wheel pant for proper tire clearance. The wheel hole will need to begin  $4\frac{1}{2}$ " AFT of the tip of the wheel pant as shown in Figure 025C-03.

**FIGURE 025C-03**

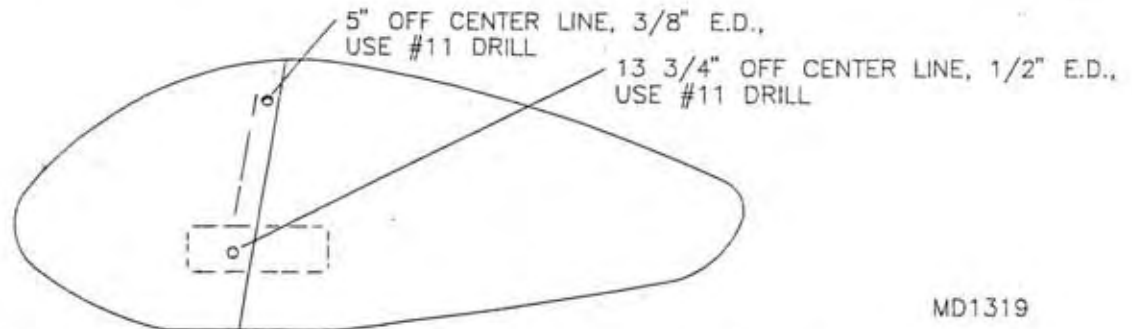


MD1039

4. Using the seam line on the AFT pant for the center line mark and cut out as shown in Figure 025C-04. A good tool to use for cutting is a portable jig saw. Finish trimming is made easy with a drum sander on a power drill. See Figure 025C-04.

**FIGURE 025C-04**

5. Locate four #11 holes in the pant while they are taped together. Mark and drill as shown in Figure 025C-05. Install the nut plates to the inside of the top AFT section to retain the upper bolts. MD1319

**FIGURE 025C-05**

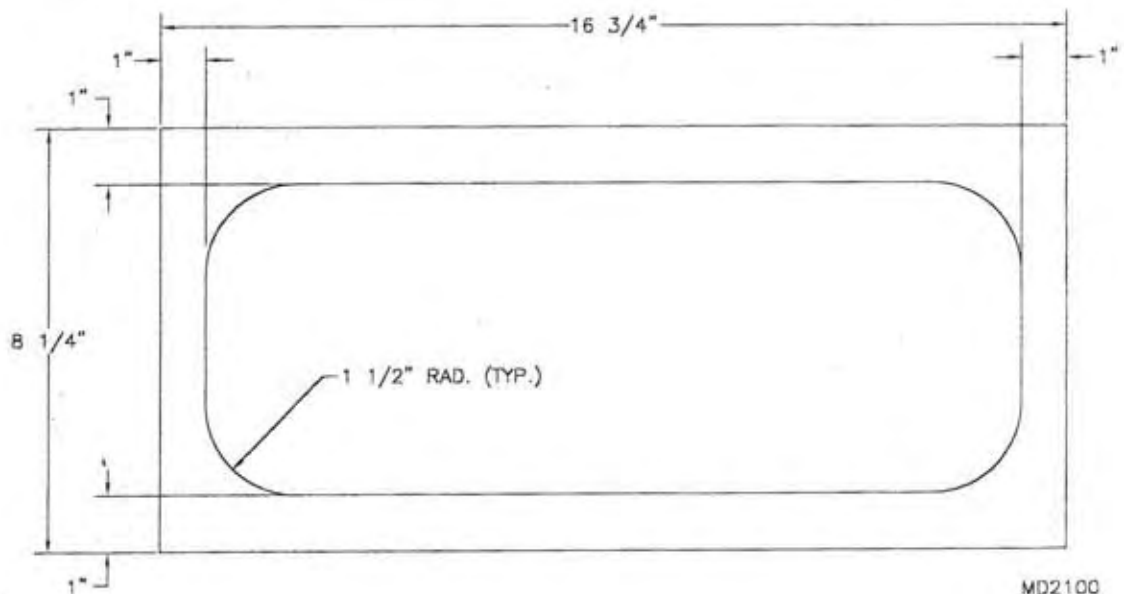
6. Pull the cotter pins out of the nose gear fork and tap the two attach sleeves into each end of the axle with the threaded ends facing out. Drill through the inserts and install new cotter pins. MD1319
7. Refer to the parts drawing and cut out and install the rubber edging as shown. Use a quick setting super glue to retain the rubber parts to the wheel pants.
8. Sandwich the two halves around the tire and slip them into place. Locate the hardware and check fit carefully and trim if necessary.
9. To paint the wheel pant it will be required to sand, fill and prime the parts. Start sanding using a good grade of wet or dry paper of at least 320 grit. After sanding you may notice a few imperfections appearing in the gel coat. These can be filled with a lacquer putty or a two part body putty. Prime the parts using a two part epoxy primer. Finish coat with the color of your choice.



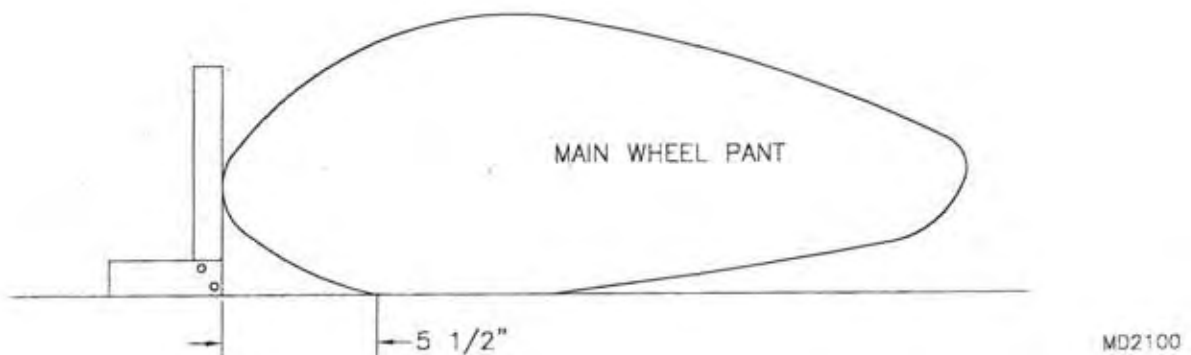
## S-6ES COYOTE II MAIN WHEEL PANT INSTALLATION

1. Press the Axle Extender into the axle until bottomed on the Axle Extender shoulder. Drill #30 through the extender using the pre-drilled axle holes as a guide. Complete Wheel and Brake assembly.
2. Make a template as shown in **Figure 25D-02** from poster board to mark the bottom hole for wheel clearance. Locate the hole 5 1/2" aft of the forward nose of the wheel pant as shown in **Figure 25D-02A**. Do not use the dimple molded into the wheel pant for hole location.

**FIGURE 25D-02**



**FIGURE 25D-02A**

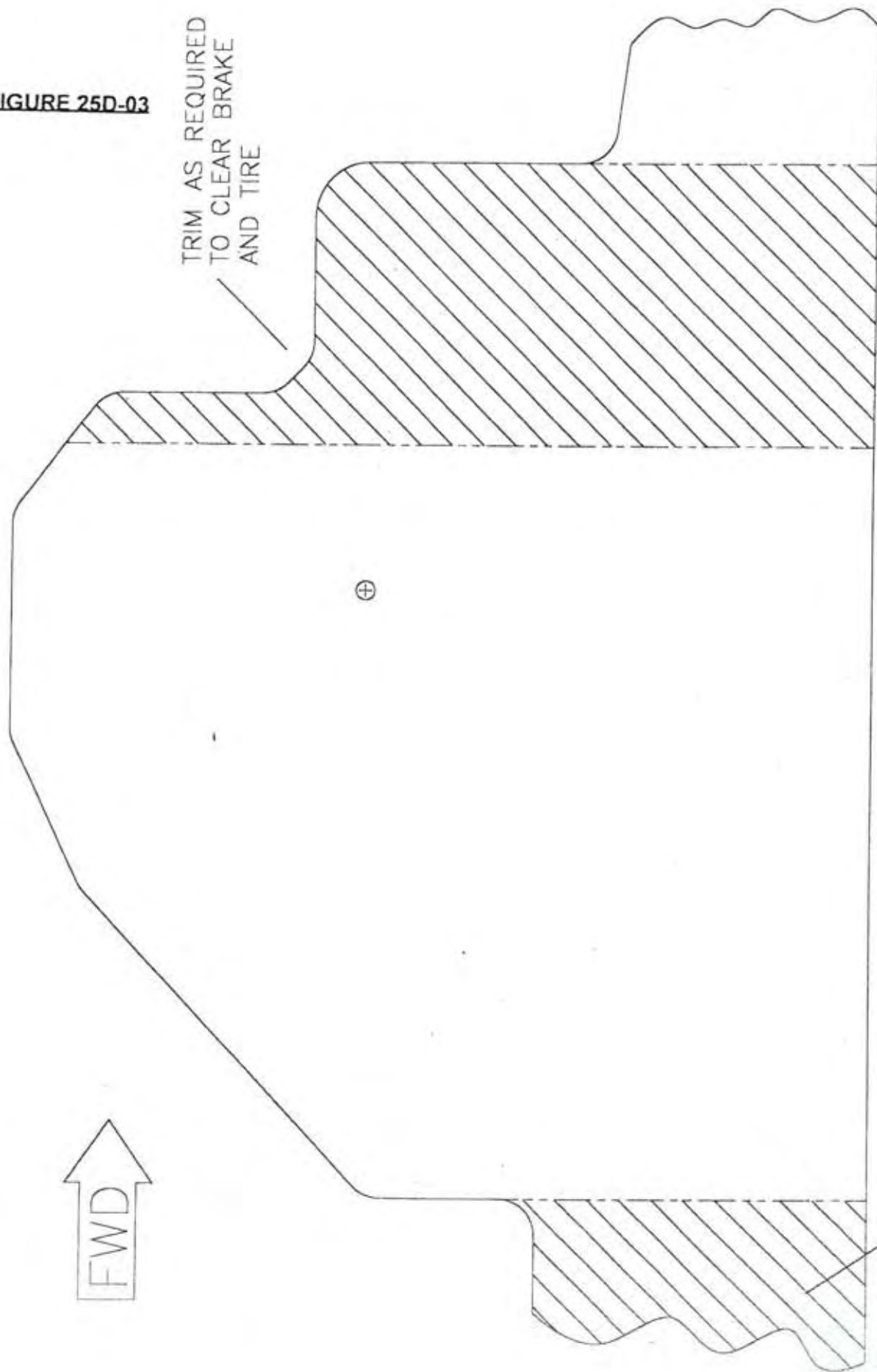


3. Make a template out of poster board as shown in **Figure 25D-03** for the brake cutout. The location of center should be 1/2" directly below the dimple on the wheel pant. Mark the wheel pant using the template. Remove the material using a fine blade jigsaw. **BE SURE** to make a right and a left wheel pant. The bolt hole on the outside of the wheel pant should also be 1/2" directly below the dimple on the wheel pant. Drill the outside hole to #11. If no dimple is present, locate the wheel pant with 3/4" to 1" clearance from the top of the tire. **HINT:** Place a small wood block on top of the wheel. Be sure the wheel is centered in the opening.

FIGURE 25D-03

025D-2

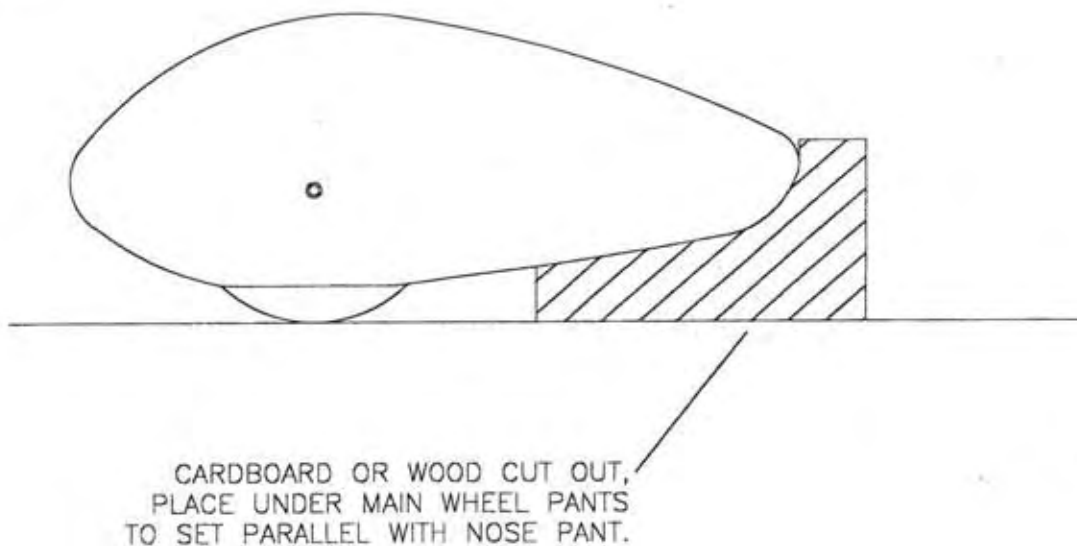
MD4476



The main gear wheel pants will need to be leveled with the nose wheel pant. Set aside the main gear wheel pants until installation of nose gear pant is complete.

- Slip main wheel pants into position. With the bolt and washer in the outside hole, position main wheel pants parallel with nose wheel pant and mark the two inside attach holes on the wheel pant mount plate as guides. See fixture idea in **FIGURE 25D-04**. Drill #11 and install hardware as shown in parts manual

**FIGURE 25D-04**



MD2126

- Install the nut plates to the outboard side of the tabs with the rivet heads to the inside. Slip the wheel pant over the wheel, spreading it enough to slip **OVER** the tabs. Install the bolts to check fit. Remove, sand and paint to match.
- Final installation of the wheel pant requires blue loctite on the axle bolts. Inspect the wheel pants for loose bolts every pre-flight.

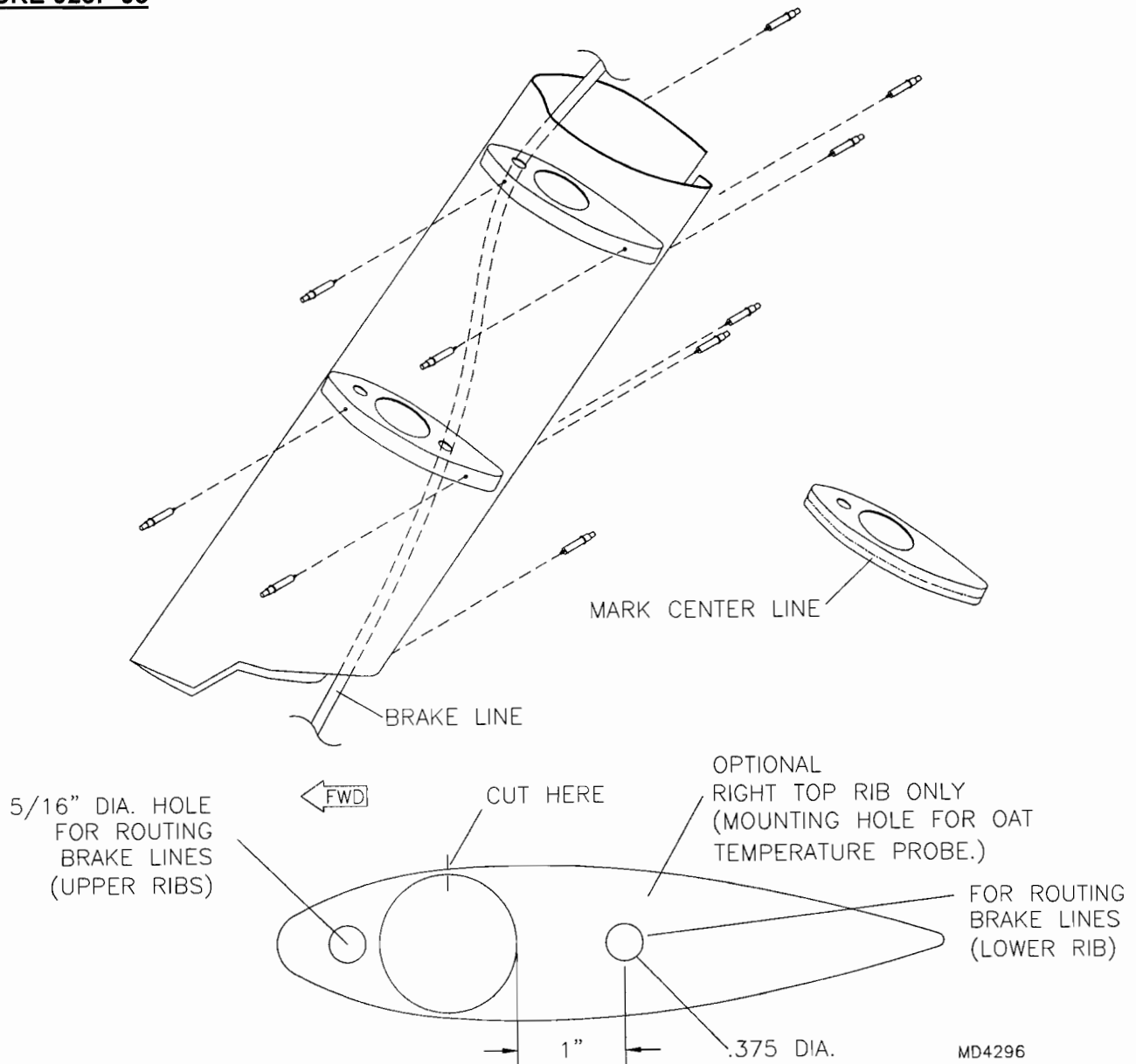
**S-6ES COYOTE II**

**This section intentionally left blank.**

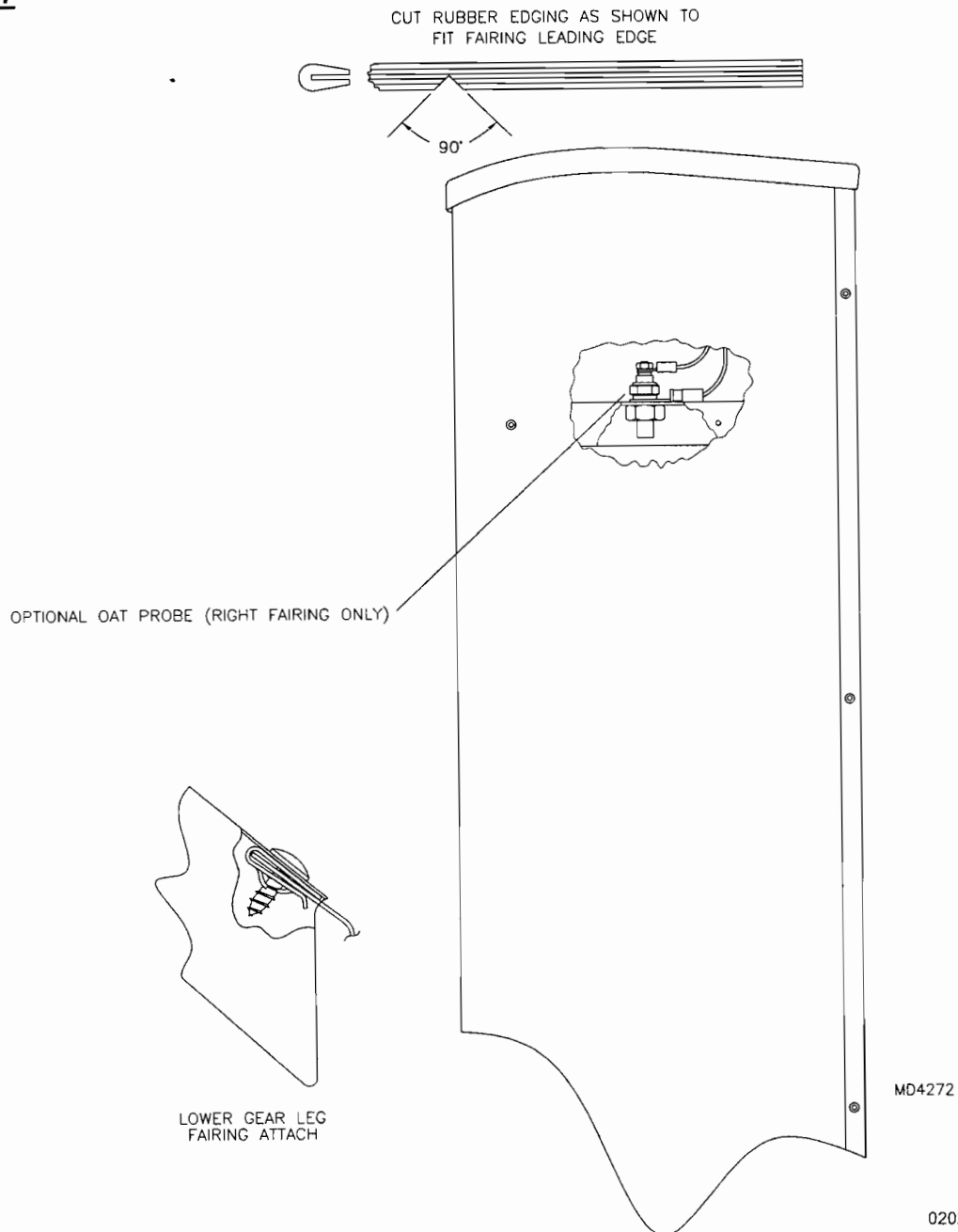
**S-6ES COYOTE II****OPTIONAL MAIN GEAR LEG FAIRINGS**

**NOTE:** Gear leg fairings may be fit up after the aircraft skin is in place. Some trimming may be required.

1. From the parts drawing and list collect the required components.
2. Bolt the Main Gear Fairing Lower Bracket to the top inboard side of the Axle Socket. Bend the bracket to align with the gear leg.
3. Trim the fairing ribs and drill per **FIGURE 025F-03**. Mark centerline, forward to aft, on each side of the rib. Insert the rib into the fairing, flange down. Align the centerline mark on the pre-drilled fairing holes. Transfer drill #40 and cleco. Mark ribs LH and RH. Transfer drill #40 the fairing trailing edge and cleco.

**FIGURE 025F-03**

4. Cut the ribs on the inboard side to allow them to slip over the gear leg. Gently twist to open and slip over the gear leg. Fit the fairing over the gear leg and ribs. Cleco the outboard side of the ribs to the fairing. Fold the fairing together and cleco. Slip the fairing over the Lower Fairing Bracket. Be sure the fairing is aligned with the aircraft belly and slipstream. Trim as required for a tight fit.
5. Drill #11 and cleco the fairing to the Lower Fairing Bracket. **HINT:** Use a hole finder or mark the holes from the underside. Remove the fairing. Install tinnermans in the fairing bracket holes.
6. Rivet the outboard side of the ribs to the fairing. Do **NOT** rivet the inboard side or the trailing edge of the fairing at this time. Remove fairings and paint to match your aircraft.
7. Cut the rubber edging to fit as shown and super glue it to the top edge of the fairing. Refer to **FIGURE 025F-07**. Slip the fairing with ribs installed over the gear leg. Route the brake line through the forward rib hole in the top rib and the aft hole in the lower rib. **IMPORTANT:** Slide a short length of anti-chafe (blue or clear fuel line) over the hydraulic brake line where it exits the bottom of the fairing. Install the gear leg fairings. Rivet the trailing edge and attach fairings to brackets with pan head screws.

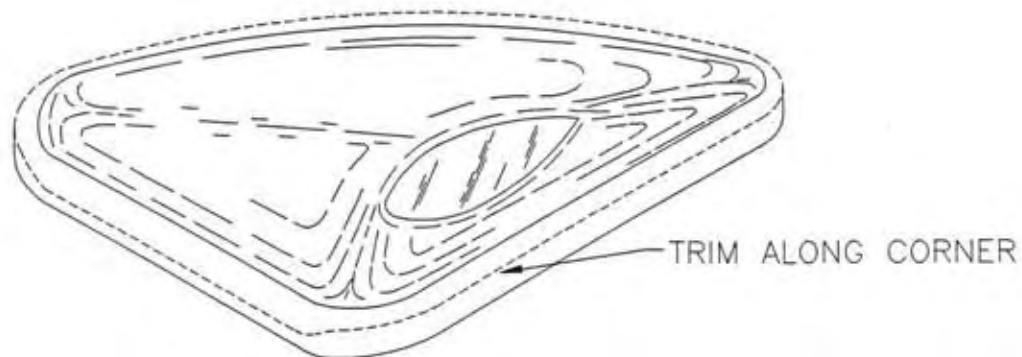
**FIGURE 025F-07**

## FILLET FAIRING INSTALLATION INSTRUCTIONS

### TRIMMING

1. The fillet fairings are made of a thermoformed lexan and need to be trimmed out carefully before beginning installation. The trim line for these fairings is actually molded into the fairings by trimming right along the corner where the mold drops straight down. See **Figure 025G-01**. Use a pair of aviation snips to rough trim, then a file or small sanding block to clean up the edges.

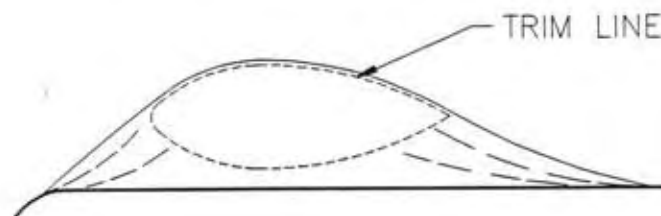
**FIGURE 025G-01**



MD317

2. There is also an airfoil shape that matches the strut material molded into the fairings. This will need to be trimmed out to fit snug over the strut. See **Figure 025G-02**. Do this by first trimming slightly inside the line, then test fit over the strut and file out accordingly until a nice snug fit is achieved.

**FIGURE 025G-02**



MD317

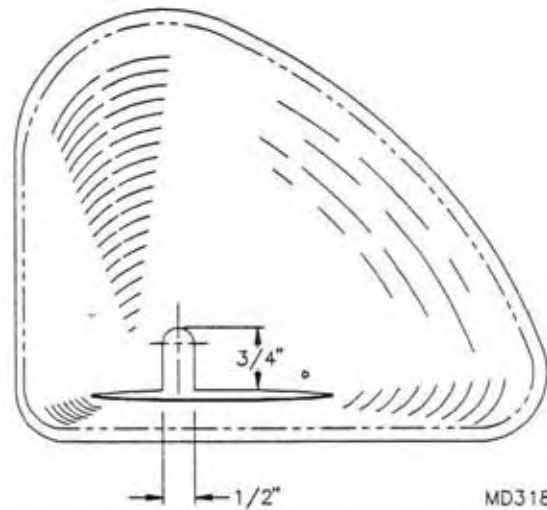
3. Also, molded into the fairing is a small indentation that is the location for the small screw that will later secure the fairing. This needs to be drilled to #40.

### INSTALLING THE FAIRINGS

4. You are now ready to begin the installation process for the fairings. First unbolt the strut fitting from the strut attach plate and let the strut drop down. Next, slip the fairing over the strut and slide it down until it hits the bolt that attaches the strut fitting to the strut. Mark an approximate centerline of this bolt, then remove the fairing and cut out a slot as shown in **Figure 025G-04**.

**FIGURE 025G-04**

NOTE: LEFT SIDE SHOWN



5. After the slot has been cut out and filed neatly, reinstall the fairings and slide it down past the bolt. Bolt the strut back in place but do not tighten until the fairing has been fit and the foam tape applied, tape application will be covered later. Push the fairing back up past the top bolt until it fits tight against the wing. Check the fit of the fairing to make sure there are no gaps around the perimeter. It is possible that the fairing may need to be twisted slightly to align with the leading edge of the wing. This can be accomplished by removing the fairings and opening up the strut hole just slightly. Once you are happy with the fit of the fairing, drill through the pre-located #40 hole into the strut. Install the screw and tighten to check fit. If everything checks out, remove the fairing and apply the foam tape provided to the perimeter of the fairing and reinstall. **IMPORTANT:** Do not use any form of loctite to secure the screw. Loctite attacks lexan and will destroy your fairing.

### TROUBLE SHOOTING

6. If the fairing does not want to fit tight against the leading edge spar, a simple fix is to add an extra screw on the forward side of the bolts in order to push the fairing up tight.
7. If the fairing seems to be sticking forward on the leading edge you will need to remove the fairing and file out the strut hole along its forward point, reinstall the fairing and slot the #40 hole accordingly. Remove the fairing, apply tape and reinstall.



## S-6ES & S-6XL COYOTE II NOSE WHEEL STRUT FAIRING

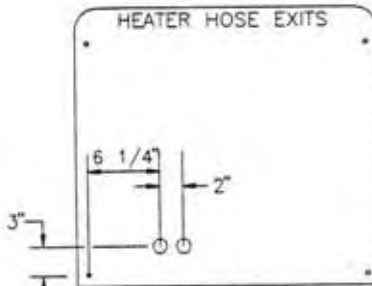
1. Slide the upper nose wheel strut fairing into the lower nose fairing. **NOTE:** The bends on both sets of fairings may need to be tightened up so they will fit together. Also, note there is an inner bend on the lower nose fairing. It is marked with an "I" on the inside by the bend. Use some vaseline to help the parts slide together.
2. After the fairings are together check to see if the holes line up with the slots. If not, file the holes slightly until they line up. If the holes are way off, check to make sure the lower fairing is assembled correctly.
3. Drill two #40 holes in the upper nose fairing. The first one is located 1/2" from the top centered on the 1/2" bend. The other is located 3 1/2" down from the first.
4. Super glue the rubber edging to the top of the fairing. Have both ends meet at the back of the fairing.
5. You will need to sand the inside bend on the lower nose fairing. (If painted, sand down to aluminum.) But do not go past the overlap of the outer bend. You will also need to sand the inside edge of the outer bend.
6. Remove the bolt from the nose strut. Slip the lower fairing around the strut, JB Weld the fairing together. A piece of masking tape around the fairing will hold it together. **NOTE:** Be careful not to get JB Weld inside where the upper fairing slides.
7. Lubricate the inside of the lower fairing with a generous amount of vaseline. Slip the upper fairing onto the strut. Rivet and assemble. Line up the holes and re-install the bolt. **NOTE:** You will only use 1 washer per side. Do not overtighten! **HINT:** If the strut has moved up have a friend pull down on the front of the engine and push back on the wheel with their feet. This will collapse the spring enough for you to insert the bolt.
8. The nose wheel pant must be attached to install the lower fairing mount angles. Align the fairing so that it is parallel to the strut. The nose fairing mounts will slip under the wheel pant's joggle seam on the inside of the fairing. The top slips inside the lower fairing. It will be just behind the strut. Drill and rivet the mounts to the fairing.

## S-6ES COYOTE II HEATER INSTALLATION INSTRUCTIONS

### FOR LIQUID COOLED ENGINES ONLY!

1. Remove the cowling and drain the cooling system.
2. Drill two 1 3/8" holes in the firewall. Hole locations are taken off the lower left side engine mount bolt. See **Figure 025-02**.

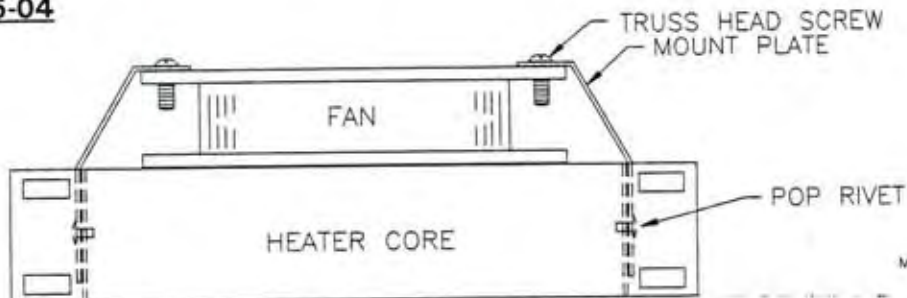
**FIGURE 025-02**



MD434

3. Assemble the fan to the radiator unit. The fan will have arrows showing the direction of air flow and the rotation. Make sure the arrow is pointing toward the heater core.
4. Attach the heater fan mount plates using the four truss head screws. The screws will self tap into the plastic housing of the fan. Orientate the fan so the wires come out on the same side as the heater core nipples. Drill two number 30 holes into the mount plate and heater core sides. Rivet with two 1/8" aluminum pop rivets. **CAUTION:** Be careful not to drill into the heater core. See **Figure 025-04**.

**FIGURE 025-04**



MD434

5. Attach the nipples to the radiator core. To do this you just simply screw them on. They are compression fittings that automatically center and create a water tight seal.
6. Locate the T's for the heater system. One T is located on the hose that comes out of the back of the engine up to the radiator. Locate the T directly across from the inner most 1 3/8" hole in the firewall. This will allow the line to come out of the T and directly into the firewall hole. The second T is located on the upper radiator hose that comes directly out of the filler neck on the engine. Locate the water valve along the second line in a place to allow connecting of the control wire. This should be in a near vertical location. Make sure you are installing the valve in the "hot" line out of the top of the engine. Route the line to the heater core from the valve through the second hole in the firewall.
7. Locate the valve control in the lower left hand corner of the instrument panel. The fan switch can be located above the valve control knob. Run the cable wire directly to the valve by going through one of the existing grommets holes in the firewalls upper left corner. It will loop around the front of the radiator slightly and run down the heater hose coming from the upper tee. Trim the control wire after

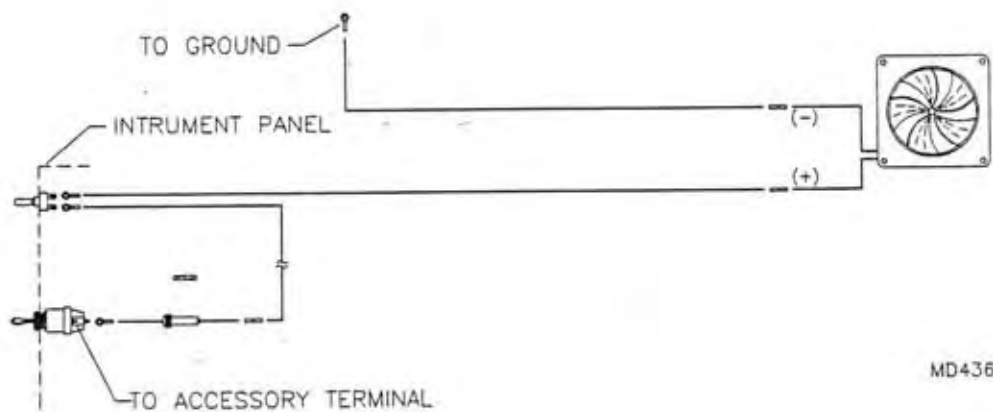
connecting, leaving 2" for adjustments. Check the control wire and housing for a secure installation. Any movement of the housing will reduce the travel stroke. If the valve cannot fully open and close, performance of the heater will be diminished.

8. On the valve is a clamp to retain the control wire housing. To retain the wire to the valve post, it must be bent in a tight loop around the post. The easiest way is to start to wrap it around, bend it into a hook shape. Slip it off the post and use a pair of pliers to hold it while completing the loop with a needle nose pliers. Twist it tight so it fits snug over the post.
9. Install anti-chafing hoses over both heater hoses at the firewall. Install anti-chafe on the upper heater hose at any point of possible contact. Split the larger hose used for anti-chafing to allow it to slip over the heater hose.
10. The heater core is attached to the two brace tubes meeting at the top middle of the firewall (cabin side). Place the heater core so the fan is blowing air down and back into the cabin. Use two 1/2" tube clamps to secure the heater core to the tubes.

With the heater mounted, slip the heater hoses onto the nipples of the core and tighten all the clamps. Check all hose and fittings for security and chafing.

Connect the wires to the fan and route them to the switch and power source as per the schematic **Figure 025I-012**. Route the wires along the underside of the crossing tube along the firewall. Run the switch wires inside the casing leading to the panel.

**FIGURE 025I-012**



MD436

13. To keep the hoses out of the rudder pedals, use a 1" cushioned clamp riveted to the firewall. Test operate the pedals to assure tangle free movement. After the hoses are clamped to the firewall install the hose covers. The cover of the hose that is clamped to the firewall will need to be cut with a hot knife to fit around the clamp, or remove the cushion off the clamp to allow clearance. Ny-tie the hoses together to clear the rudder pedals.
14. Fill the system with coolant and check for leaks. Test run the engine and inspect for leaks and operation. The heater should produce noticeable heat within a few minutes of starting the engine. Depending on how well your cabin is sealed and the outside air temps, the heater should be able to keep the cabin warm enough for extended flying on winter days, or at altitude. Do not expect the heater to keep up if you have a lot of air leaks in your cabin, or if it is extremely cold (below 20 degrees F). Installing the AFT cabin wall interior system will seal the air leaks and increase the heater comfort level. Consider this option if you fly in cold weather a good part of the time.

## **S-6ES, S-6XL & S-6S COYOTE II STROBE INSTALLATION**

1. To install the strobe, the tip bow cannot protrude more than 1/4" into the trailing edge spar. The end of the tip bow may have to be filed to allow a good fit. Drill a 1/2" hole centered on the AFT side of the trailing edge spar 1/2" from the edge. See **Figure 025J-01**. Trim the excess aluminum between the hole and the edge of the spar to form a cup shaped slot. Glue the small rubber edge into the slot to protect the wires:

2. Cut out a 1/2" notch on the AFT side of the nav. light tip mount. Slide the mount into the spar. Check for fit and clearance with the flap. Take 3 screws (that hold the light plate to the mount) and shorten the screws for a flush fit on the back side of the mount. You will have to drill out the 3 holes on the light plate to #11 to get the screws to fit.

3. Screw the light plate and the mount together. Pull enough wire out of the spar to make it easy to work on. Connect the wires. There are two blue wires. One connects with the black ground wire and the other connects to the red wire which will connect to the hot yellow wire with a splice. The blue and black wires will be connected by an eye terminal and grounded to one of the screws that holds the plate and mount together. Use electrical tape to secure the wires together.

4. Have a friend pull the wires through on the other end until the strobe plate and mount reach the spar. Make sure no wires are pinched. Line up the mount with the wing and flap. Drill a #30 hole on the top and bottom. Rivet the mount into the spar with two 1/8" SSPR's. Install the glass lenses and end caps to hold the lights in place. Apply about one foot of anti-chafing material to the wires coming out of the wing.

5. Install the strobe power supply box. The box mounts at station #3 with 3/4" non-cushioned clamps. **NOTE:** The strobe box has high voltage, keep clear of auxiliary tank and fuel lines. The box can be mounted upright or lying flat. Run a 14 gauge yellow wire from the Nav. switch back to the strobe box. Connect a brass "Y" to the end of the wire. The yellow wire coming out of each wing will connect the "Y". Run a red 14 gauge wire from the strobe switch back to the strobe box. Also, run a black 14 gauge wire back to the switch for the ground. Connect these wires to the black and red wires coming out of the strobe box.

6. Connect the ends, provided in the strobe kit, to the 3 wires coming out of the gray wire. The kit has directions about which way they go on. Red connects to #1, black connects to #2, and white connects to #3. Make sure these ends are pushed up all the way into the connector.

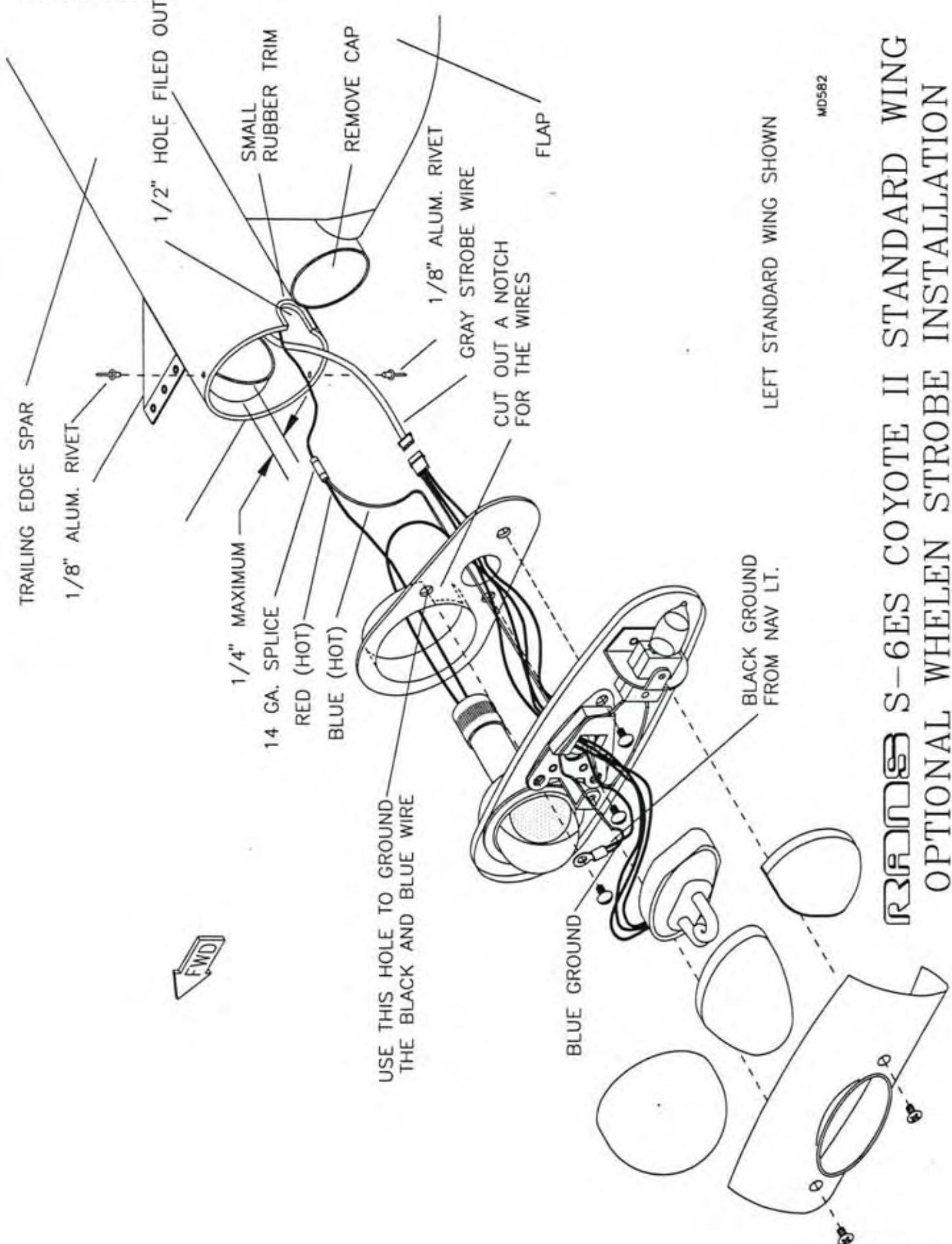
7. The unprotected wire is grounded to the box by a bolt. The two white connectors, from the gray wire, are plugged into the number 1 and 2 outlets. Check all connections and wires. Test the strobes.

## **S-6ES COYOTE II 116 STROBE INSTALLATION**

1. Locate a hole about 8" from the trailing edge of the tip bow. Make the hole just big enough to pull the two wires out that were taped to the tip before skinning the wing.

2. Rivet the three nut plates to the light tip mount. Use #40 1/8" PR's. The light plate will screw to the light mount. You will have to drill out the 3 holes on the light plate to #11 to get the screws to go through.

FIGURE 025J-01

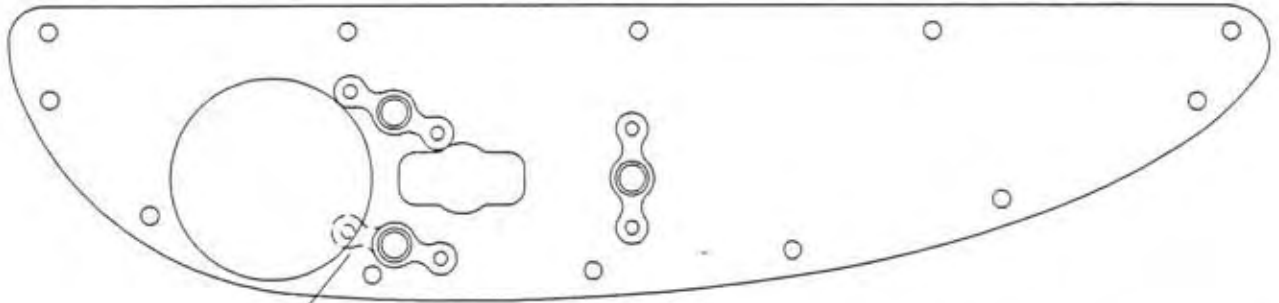


MD582

**RRR S-6ES COYOTE II STANDARD WING**  
**OPTIONAL WHELEN STROBE INSTALLATION**

3. Cut out the nav. light cuff. The bottom side (which will rest against the skin) should have about a 3/4" edge dimension. Next, cut out the side where the mount plate will be riveted. This should have a 1/2" edge dimension. Drill and rivet the mount plate using the seven bottom holes with #30 1/8" aluminum rivets. Use 1/8" washers for backing against the cuff. Place weather striping on the edge that rests against the bottom side of the wing skin. See **Figure 025J-03**.
4. Screw the light plate and the mount together. Pull enough wire out of the spar to have room to work with. Connect the wires. There are two blue wires. One connects to the black ground wire and the other connects to the red wire which will connect to the hot yellow wire by a splice. The blue and black wires will be connected by an eye terminal and grounded to one of the screws that holds the plate and mount together. Use electrical tape to secure the wires together.
5. Place the nav. light mount plate 2 1/2" from the trailing edge of the tip bow. Trim the upper ends of the reinforcement straps as necessary to mount the plate to the bow.
6. Have a friend pull the wires through on the other end until the strobe plate and mount reach the tip bow. Drill #30 holes for mounting the nav. light mount plate and rivet into the tip bow with five 1/8" aluminum rivets. See **Figure 025J-06**. Install the glass lenses and end caps to hold the lights in place. Apply about one foot of anti-chafing material to the wires coming out of the wing.
7. Install the strobe power supply box. The box mounts at station #3 with 3/4" non-cushioned clamps. **NOTE:** The strobe box has high voltage, keep clear of auxiliary tank and fuel lines. The box can be mounted upright or lying flat. Run a 14 gauge yellow wire from the nav. switch back to the strobe box. Connect a brass "Y" to the end of the wire. The yellow wire coming out of each wing will connect the "Y". Run a red 14 gauge wire from the strobe switch back to the strobe box. Also, run a black 14 gauge wire back to the switch for the ground. Connect these wires to the black and red wires coming out of the strobe box.
8. Connect the ends, provided in the strobe kit, to the 3 wires coming out of the gray wire. The kit has directions about which way they go on. Red connects to #1, black connects to #2, and white connects to #3. Make sure these ends are pushed up all the way into the connector.
9. The unprotected wire is grounded to the box by a bolt. The two white connectors, from the gray wire, are plugged into the number 1 and 2 outlets. Check all connections and wires. Test the strobes.

**FIGURE 025J-03**



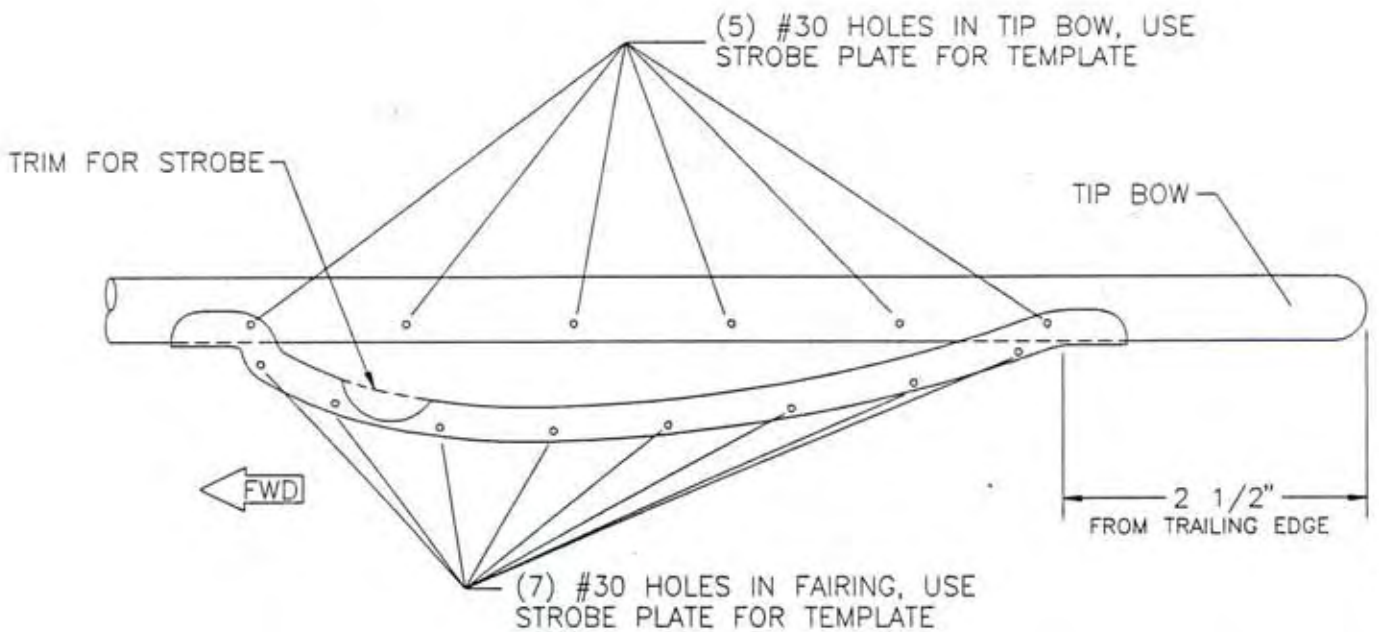
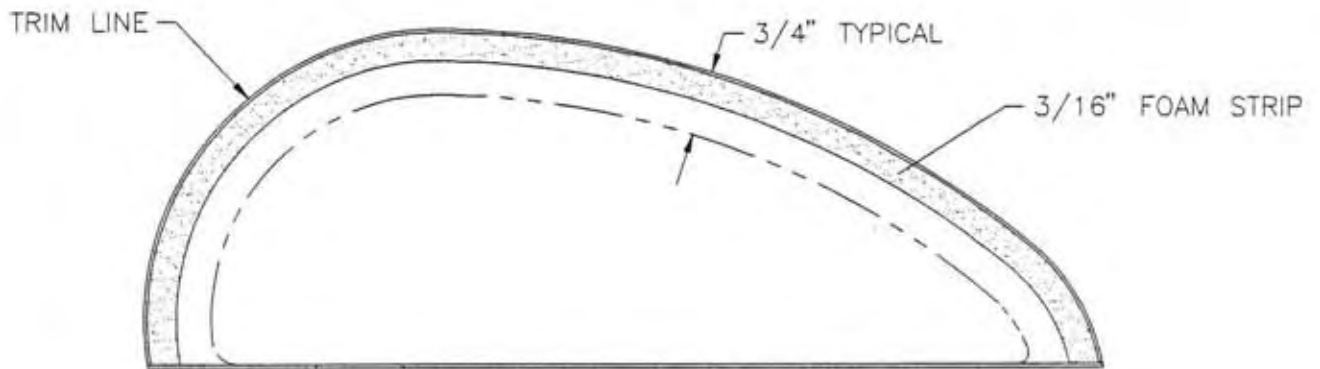
← TRIM ONE SIDE OF NUT PLATE FOR CLEARANCE

PLACE NUT PLATES AS SHOWN

(3) NUT PLATES REQ'D. PER ASSEMBLY

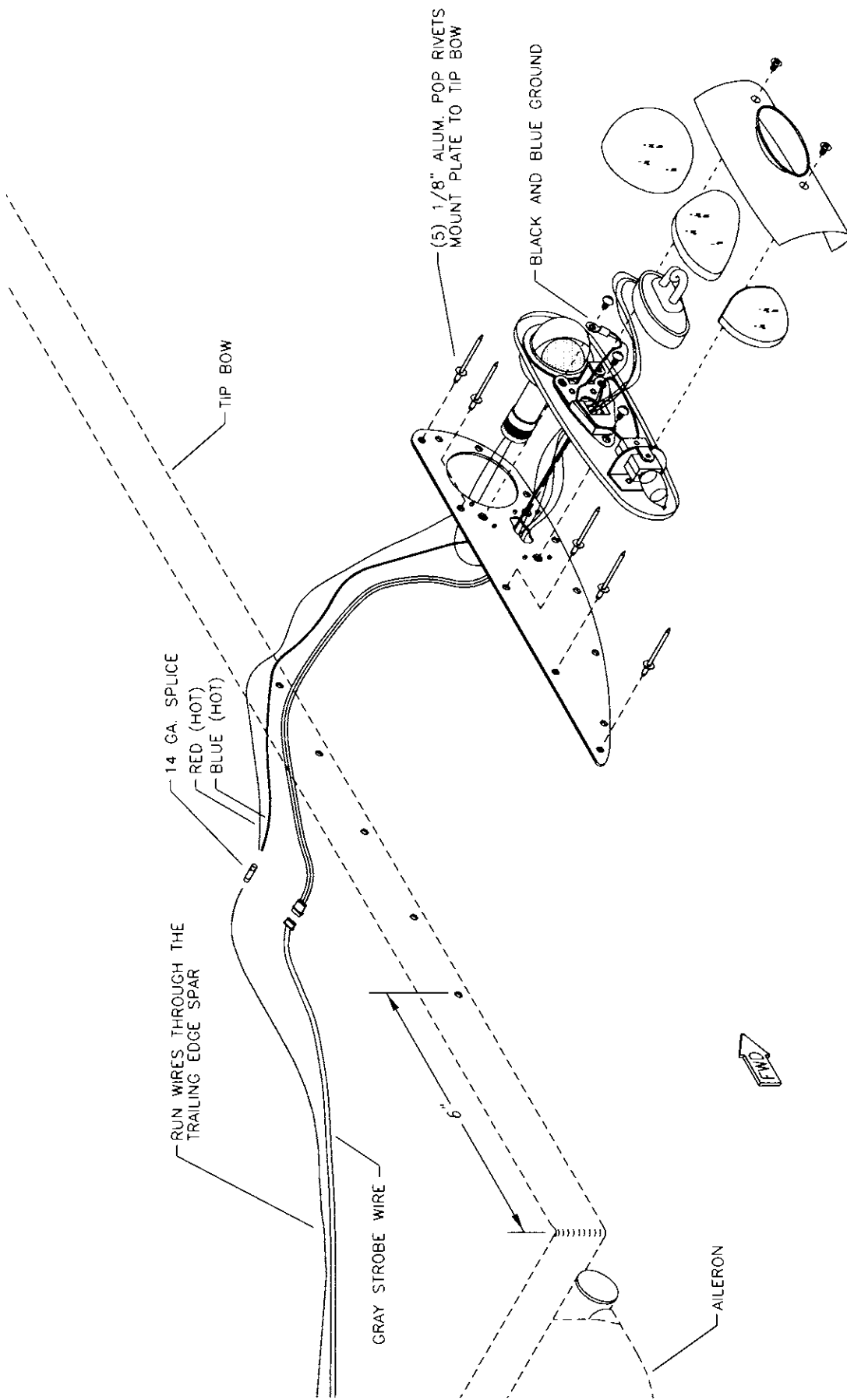
(6) #40 POP RIVETS REQ'D. PER ASSEMBLY

MD584



MD584

FIGURE 025J-06



40583

RIGHT 116 WING SHOWN

# RAMS S-6ES COYOTE II 116 WING OPTIONAL WHELEN STROBE INSTALLATION



S-6ES COYOTE II

**This section intentionally left blank.**

**S-6ES COYOTE II**

**This section intentionally left blank.**

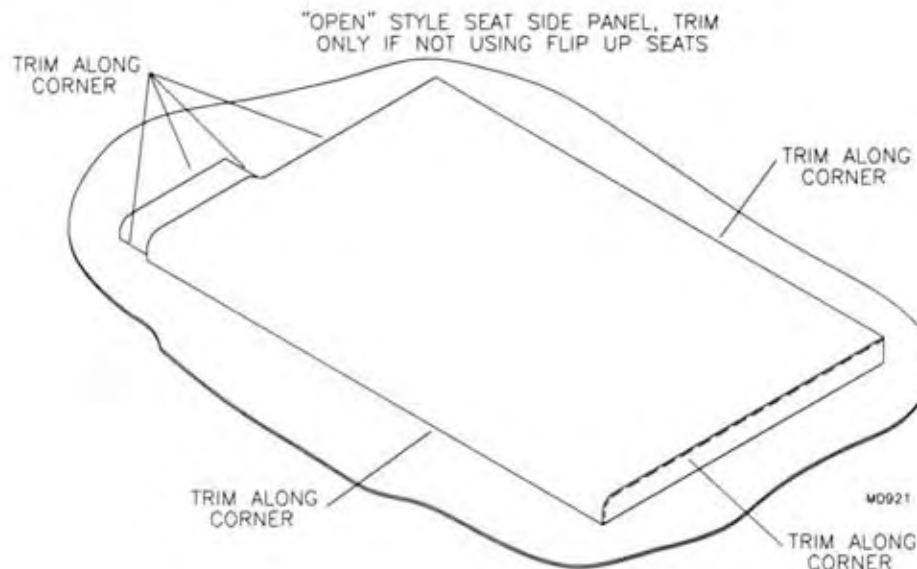
**S-6ES COYOTE II**

**This section intentionally left blank.**

## S-6ES COYOTE II MOLDED INTERIOR INSTALLATION

1. Un-pack the interior kit. Inventory the kit against the packing list. The components are carefully packed and should arrive intact. Inspect the panels prior to trimming and assembly.
2. Look over the parts closely. You will notice trim lines molded into the parts. The parts will need to be trimmed and holes made accordingly. To trim, use a tin snip or a heavy duty scissors. For other openings use a Dremel tool with a rotary file. For clean edges use a Dremel tool and a small sanding drum. A fine 1/4" diameter rat tail file will also work. To true up long straight edges, sand with a block and 80 grit sand paper. Smooth any other edges with a file.
3. Locate the back panel. Refer to **Figure 025N-03**. This illustrates the various cut outs and trim lines. In views B and C it shows to leave at least 3/32" of an edge. Later, rubber inserts will be glued to these edges.
4. Trim the baggage compartment panel. **NOTE:** There are two different cut out patterns for the trike and the taildragger. See **Figure 025N-04**. Do not cut out the opening for the baggage compartment at this time.
5. Determine if you are installing the flip up seat. Trim the respective parts for the seat type in your kit. See **Figure 025N-05**, **025N-05A** & **025N-05B**. For the flip up seats we have included extra rubber that can be glued into the seat belt openings in the same manner as on the back panel.

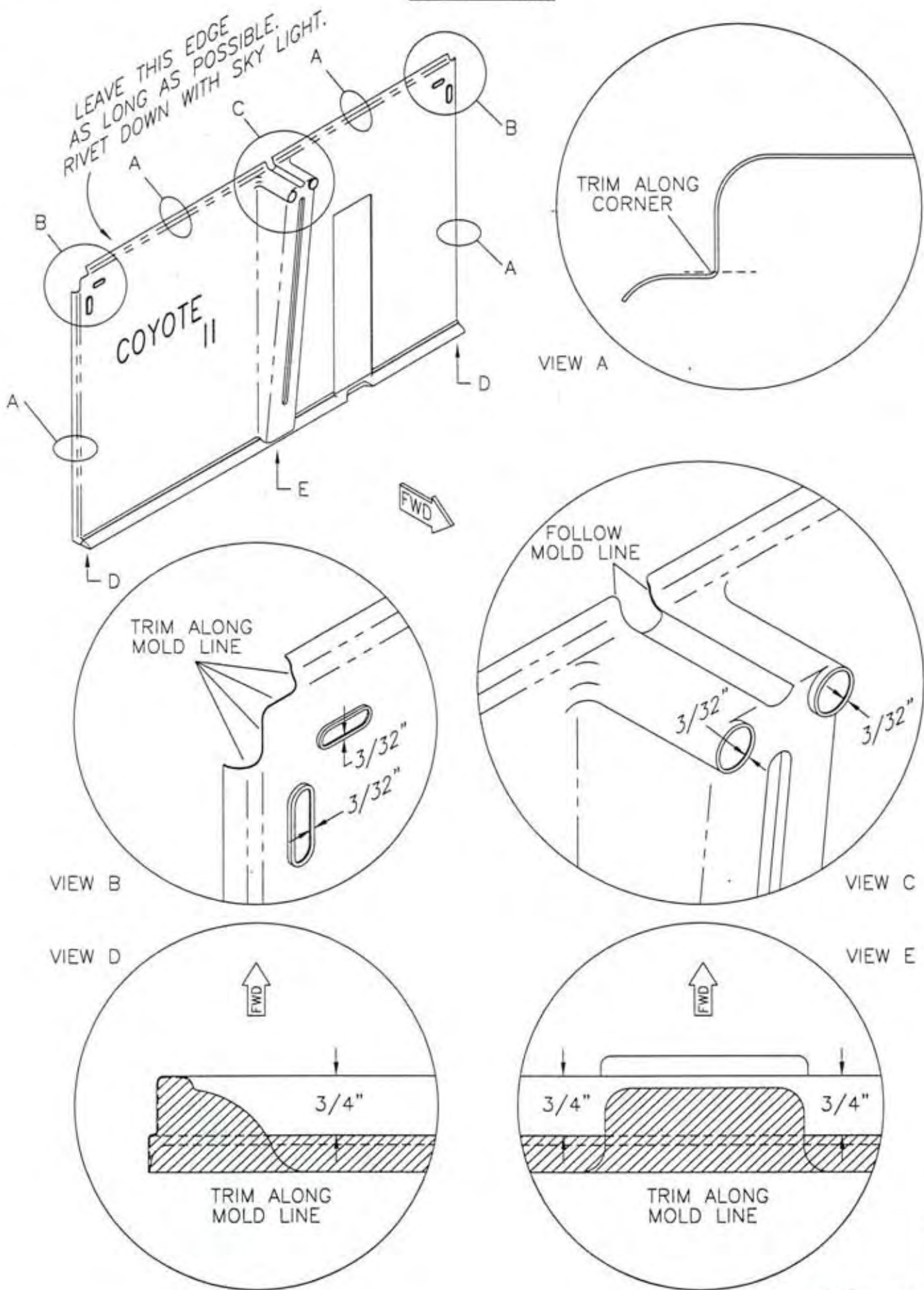
**FIGURE 025N-05**



6. Trim all other components as per **Figures 025N-06 thru 025N-06F**. For the lace up type seat, not the flip up style, trim out the slot in the control stick panel molding. See **Figure 025N-06G**. For dual throttles, trim out the openings also.
7. Cut the rubber inserts from the rubber sheet as shown on the template. See **Figure 025N-07**.

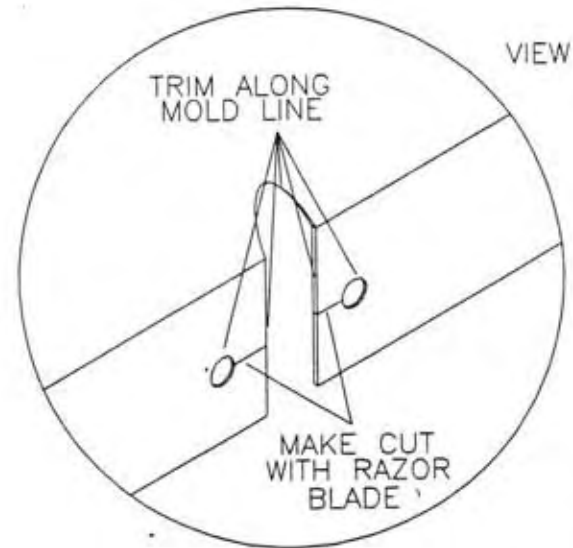
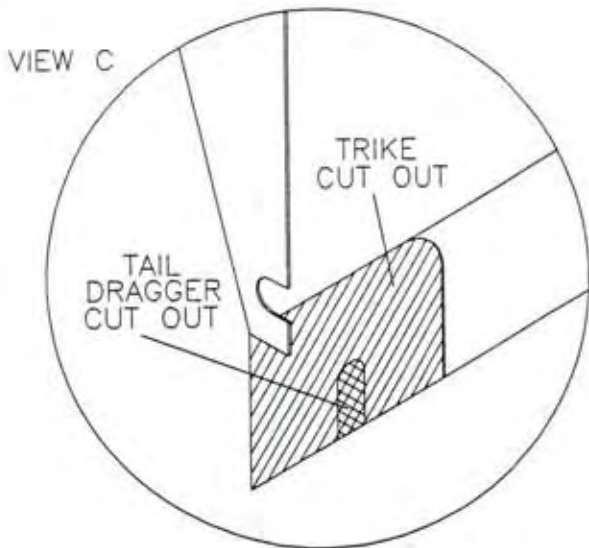
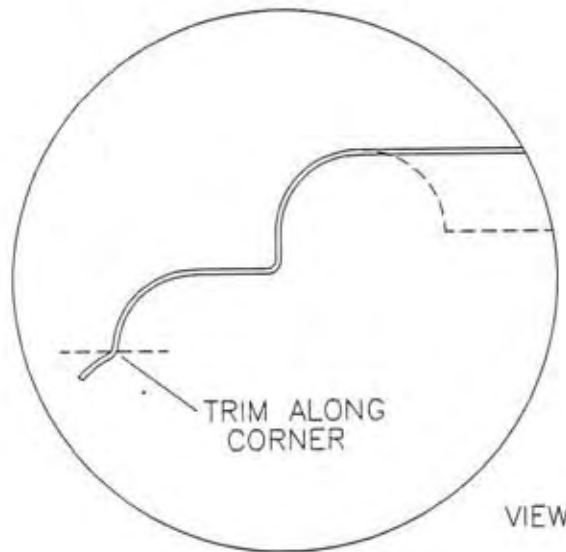
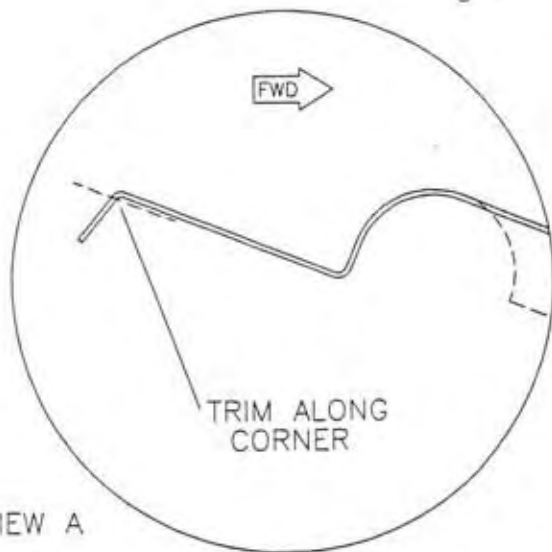
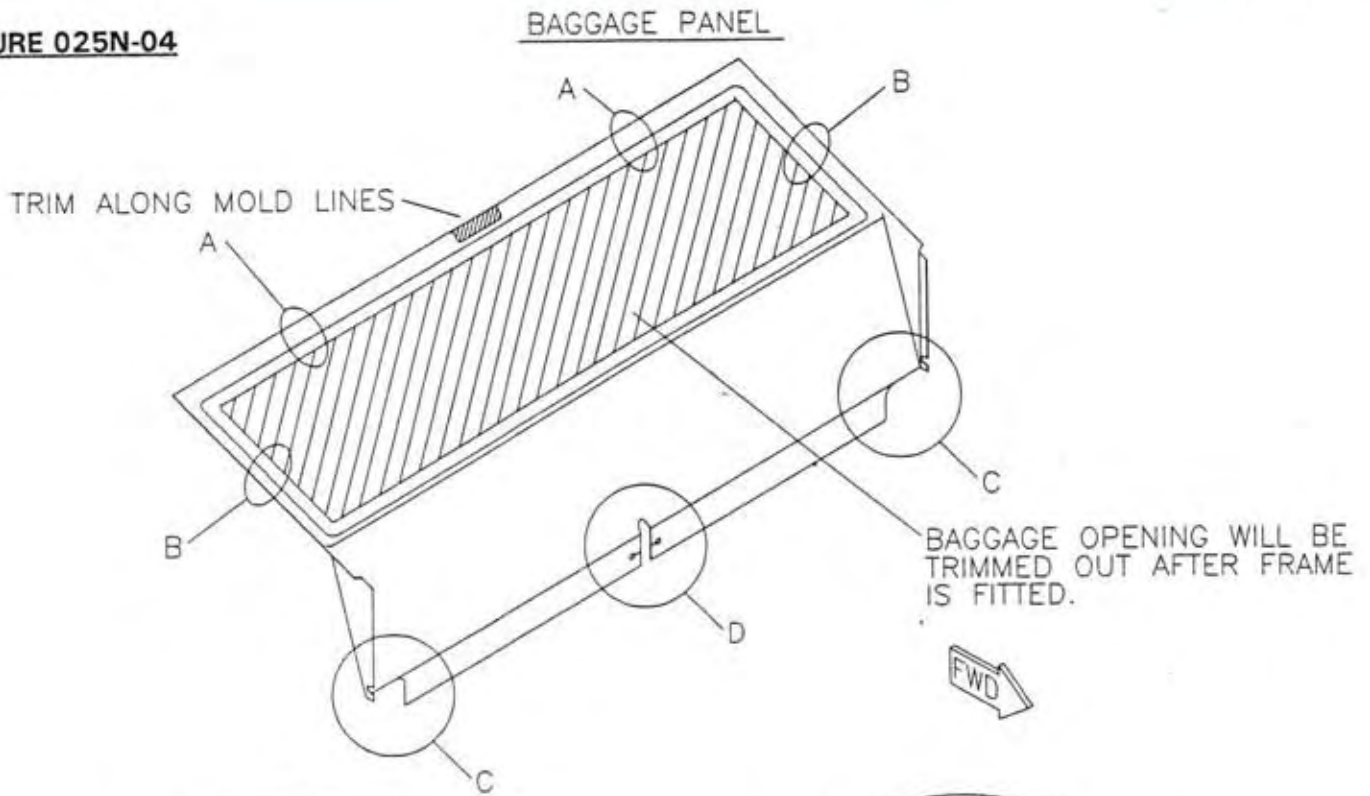
FIGURE 025N-03

BACK PANEL



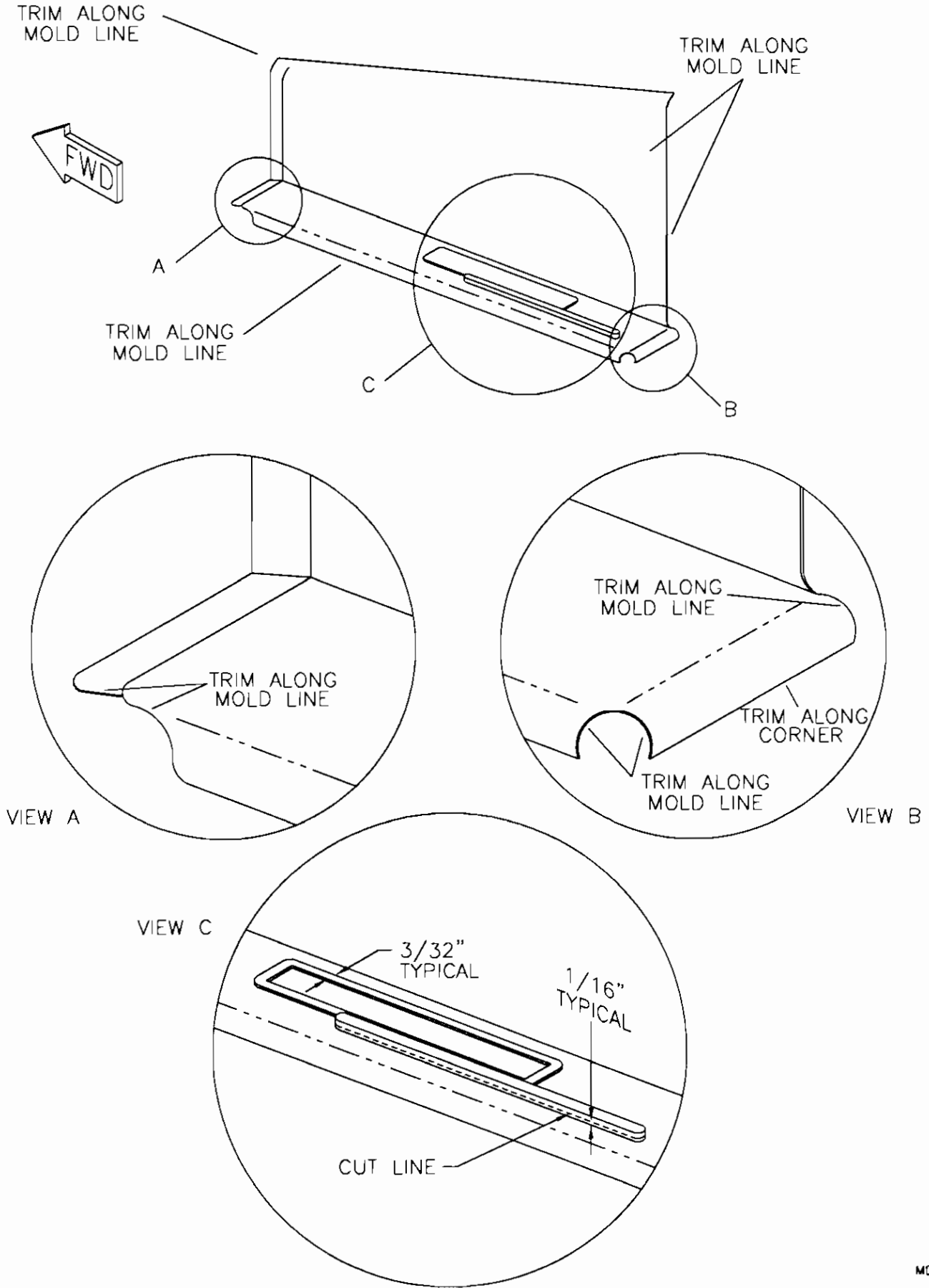
M0907

**FIGURE 025N-04**

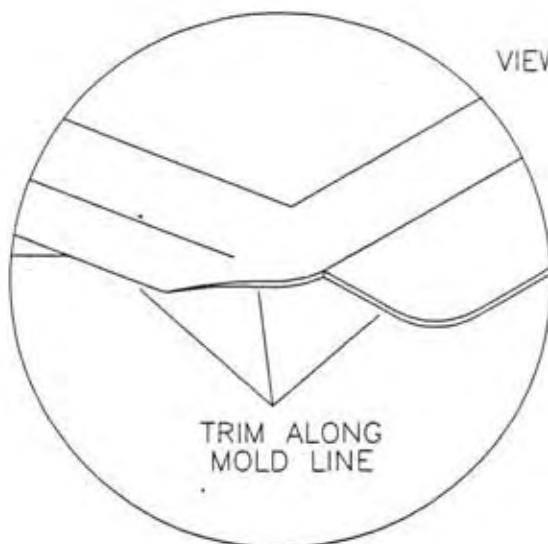
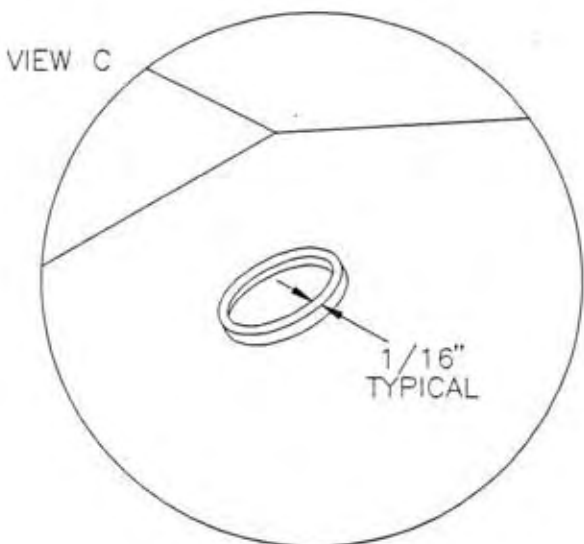
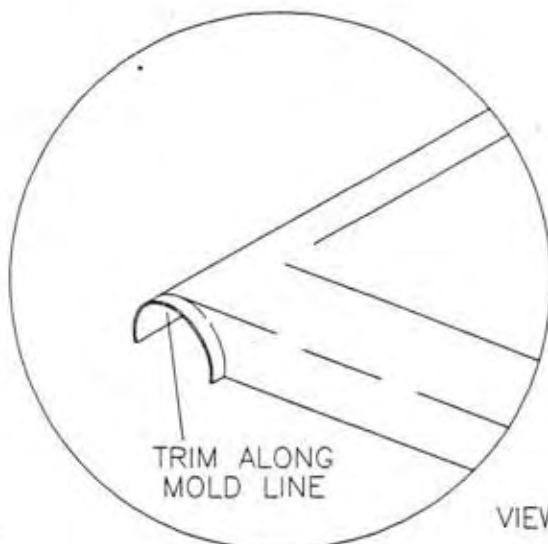
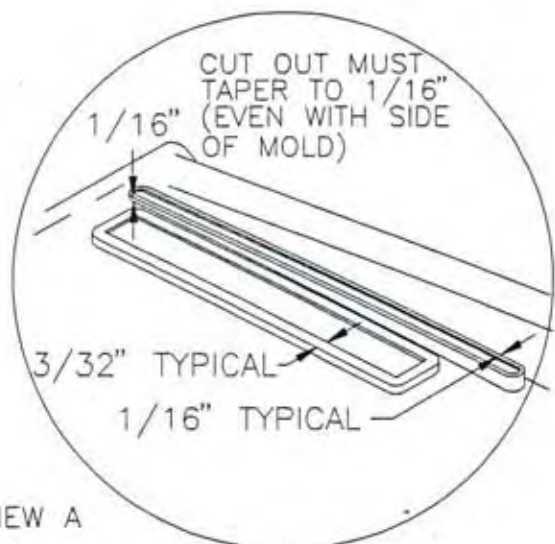
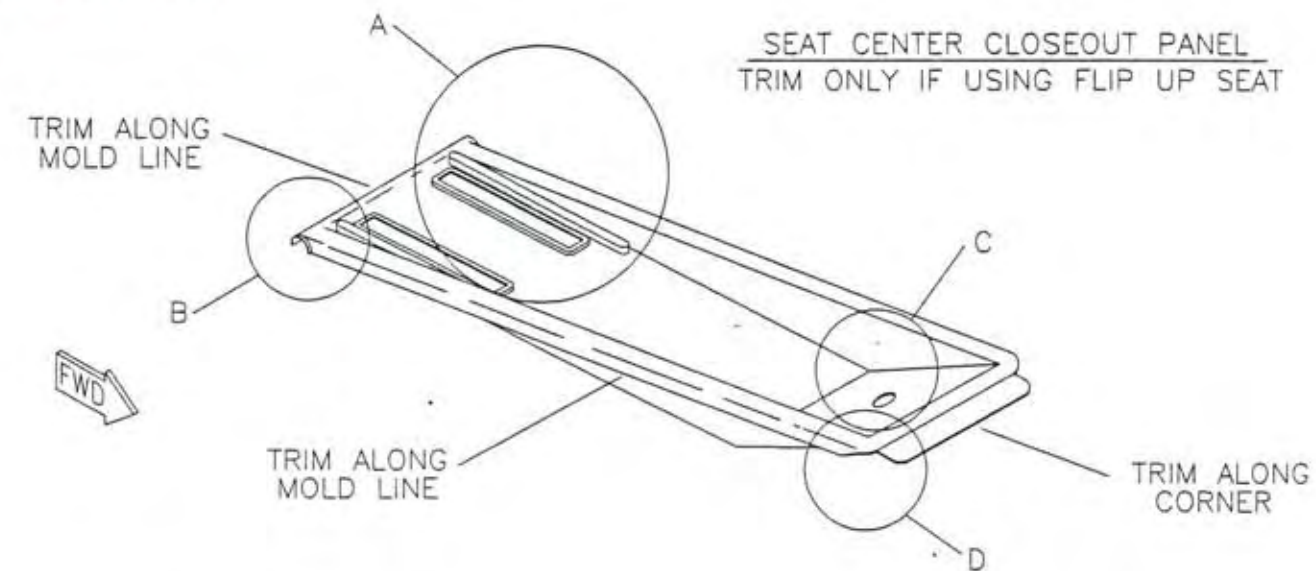


**FIGURE 025N-05A**

SEAT SIDE PANELS



**FIGURE 025N-05B**

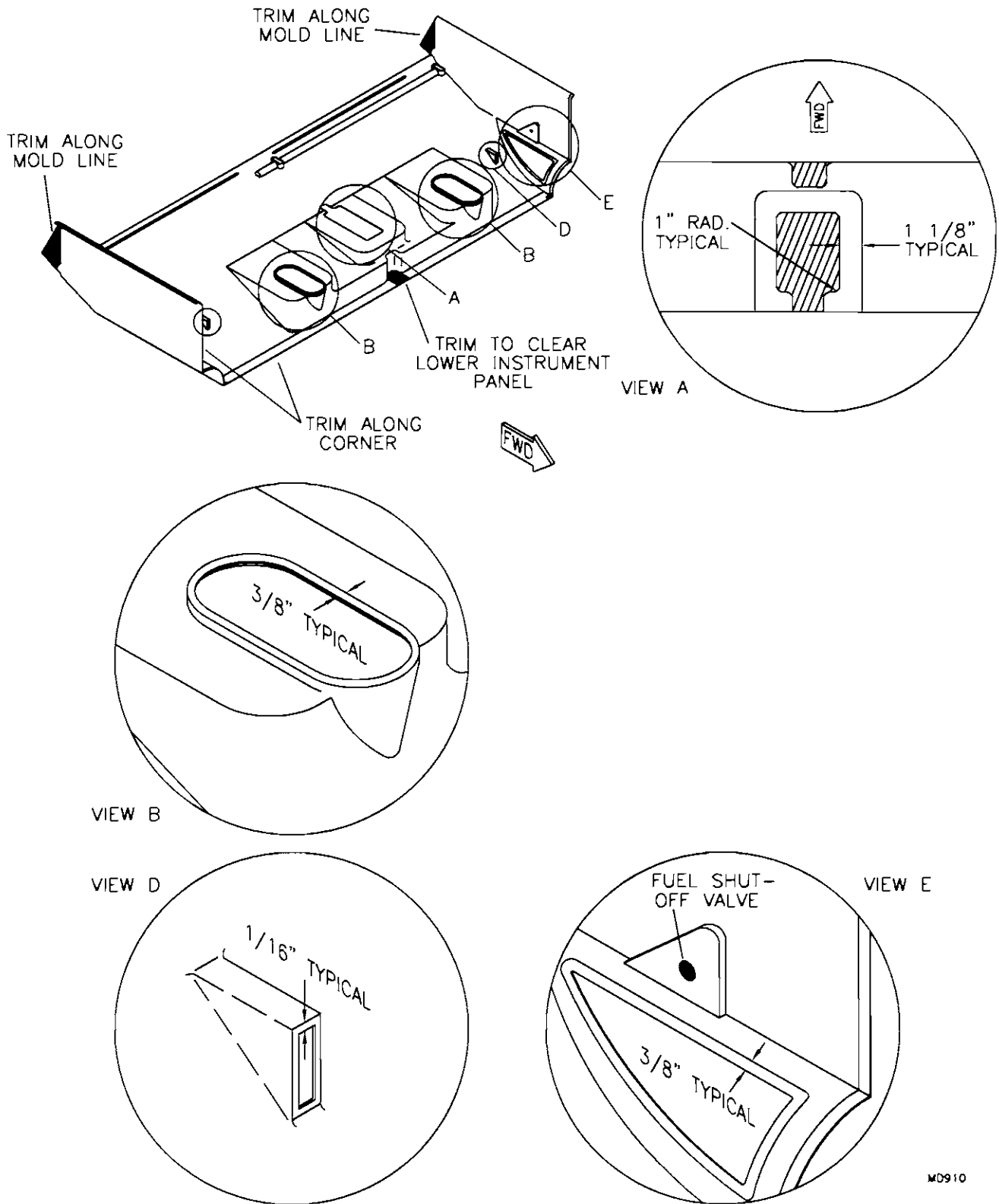


MD917



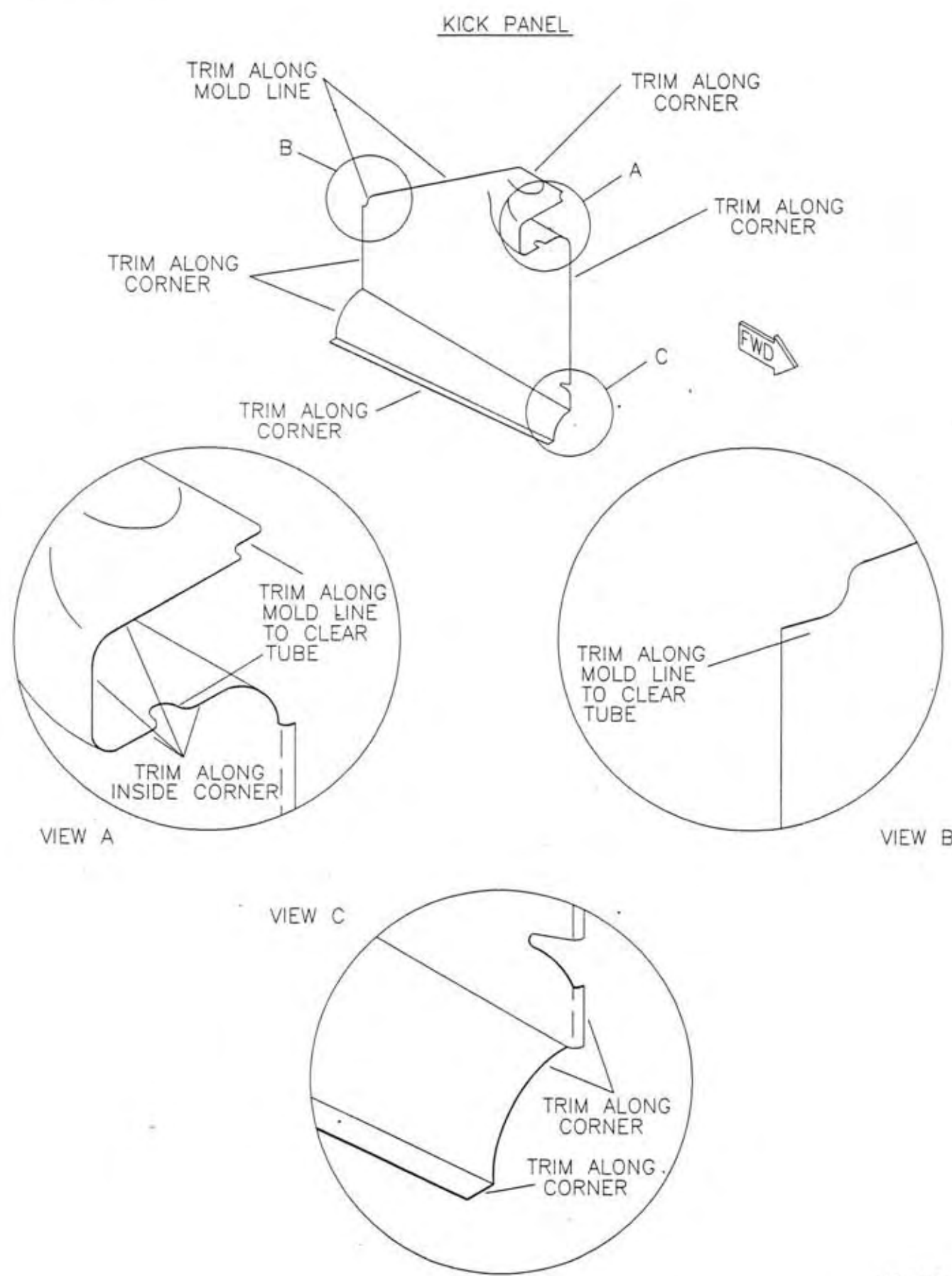
**FIGURE 025N-06**

CONTROL STICK PANEL



**RANS S-6ES**  
**MOLDED INTERIOR, FLOOR MOLD FIG. 25N-06**

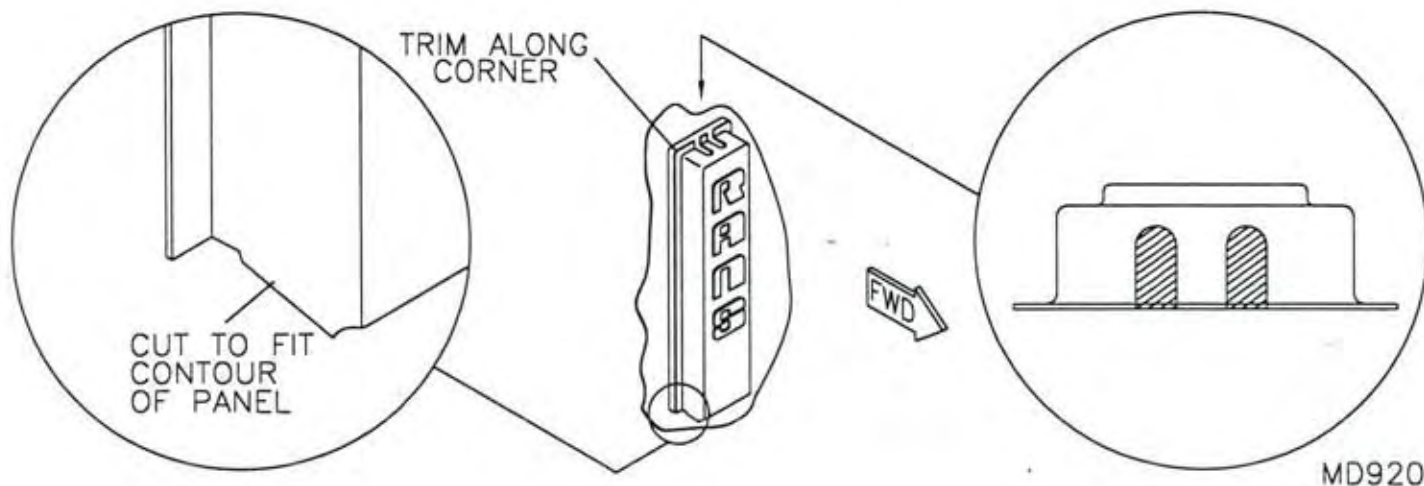
**FIGURE 025N-06A**



MD919

**FIGURE 025N-06B**

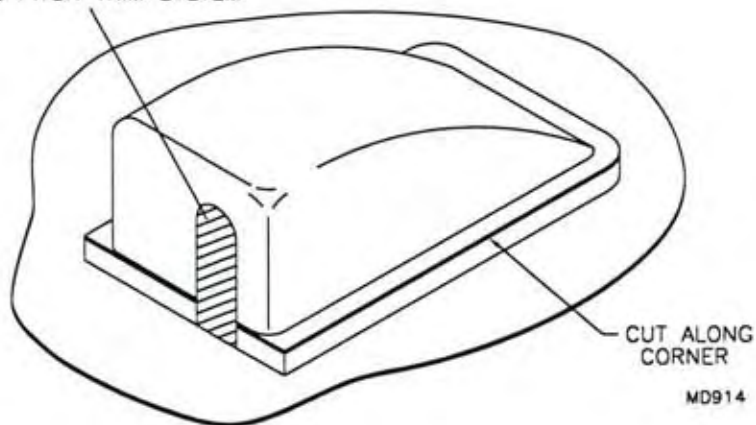
FLAP TELEFLEX COVER



**FIGURE 025N-06C**

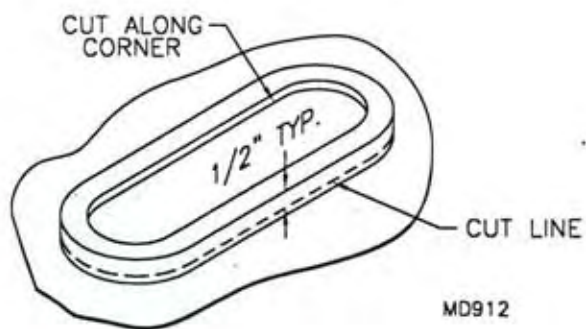
TORQUE TUBE INSPECTION COVER

TRIM THIS AREA ONLY S-6ES  
BUNGEE PITCH TRIM SYSTEM



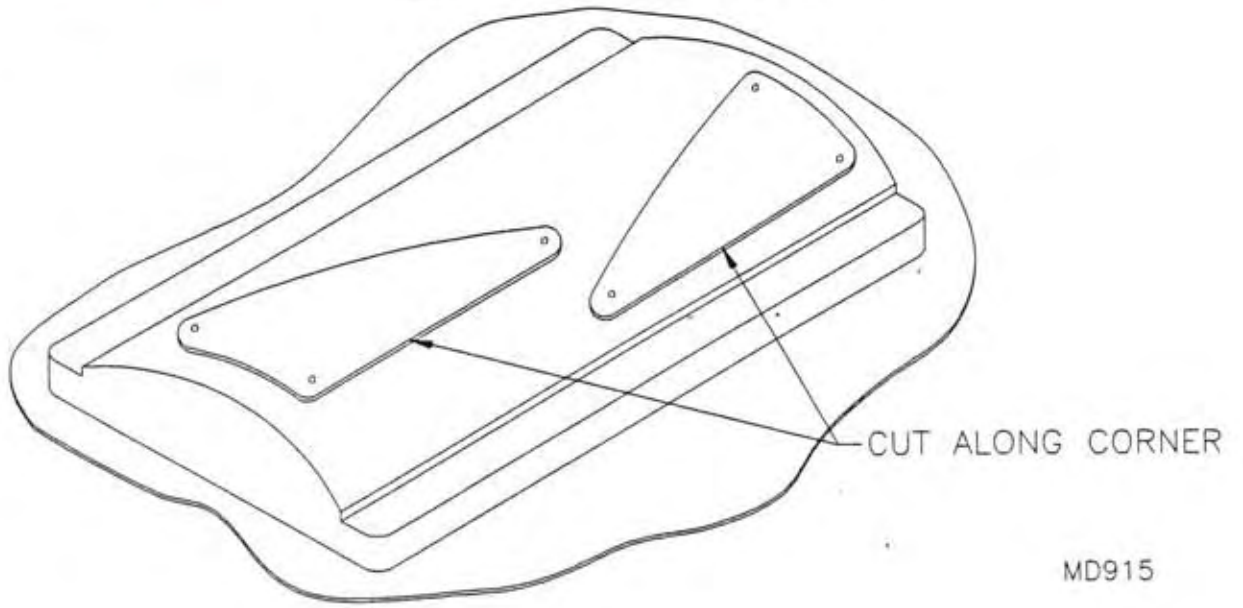
**FIGURE 025N-06D**

BOOT RETAINER



**FIGURE 025N-06E**

INSPECTION PANEL COVER



**FIGURE 025N-06F**

LOG BOOK POCKET

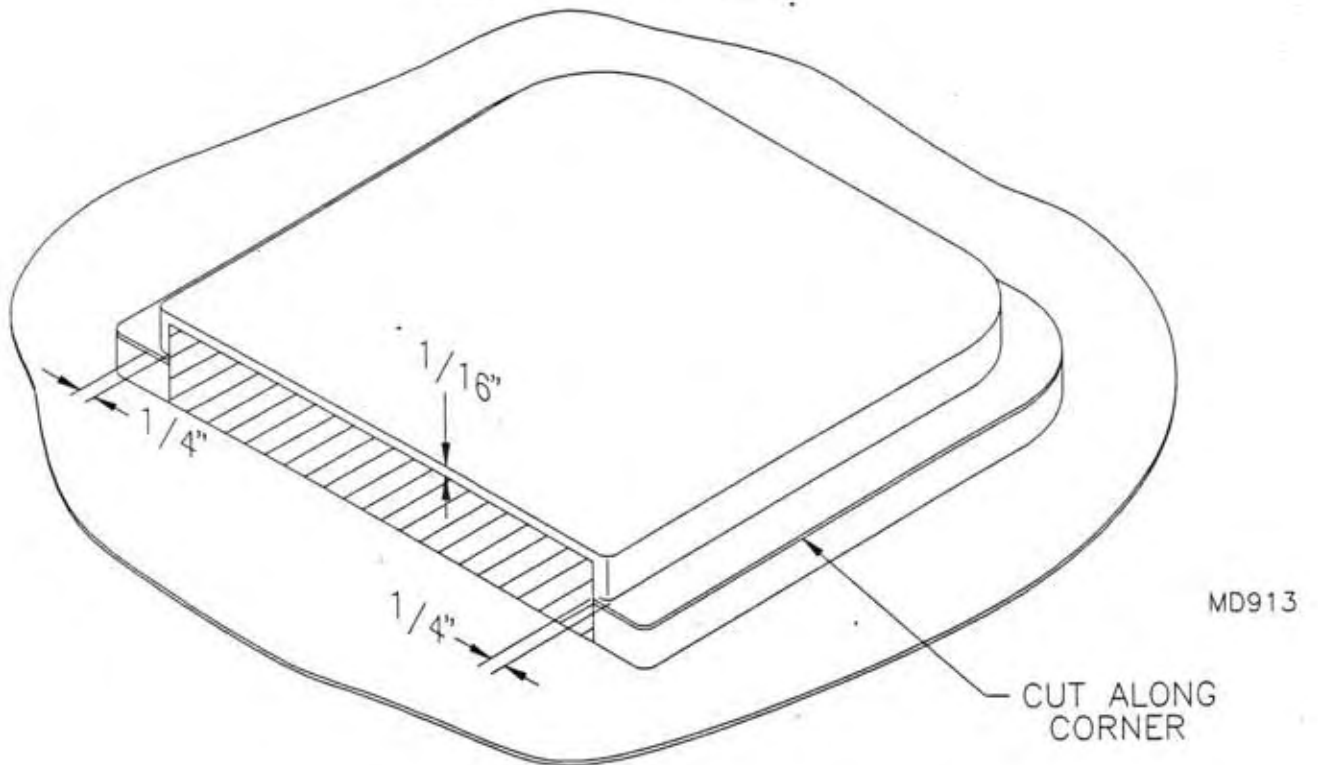


FIGURE 025N-06G

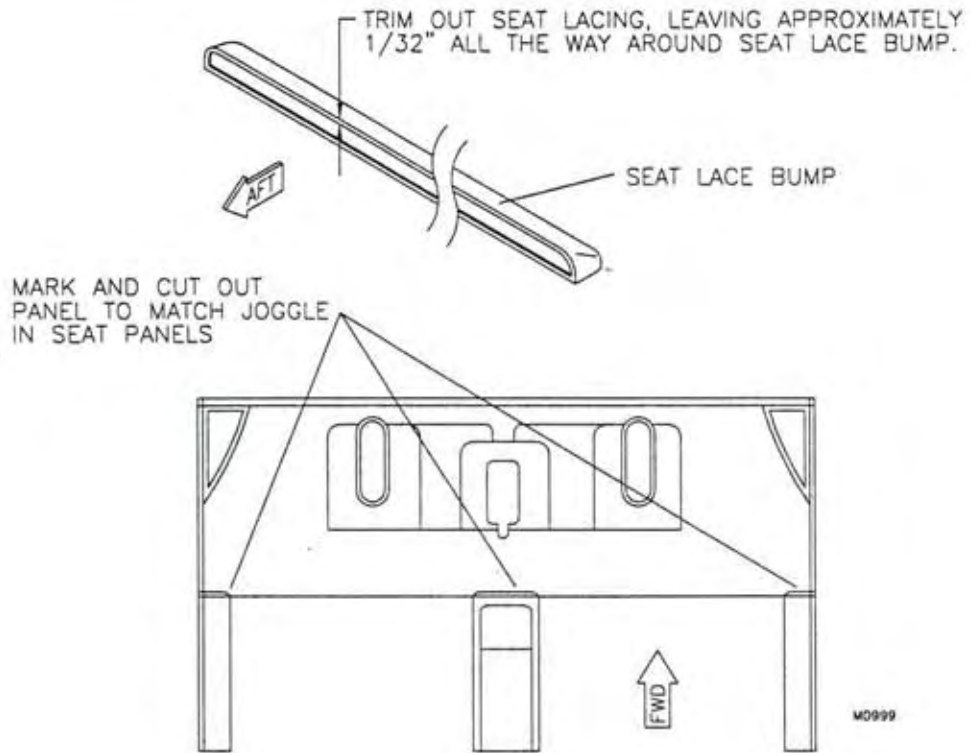
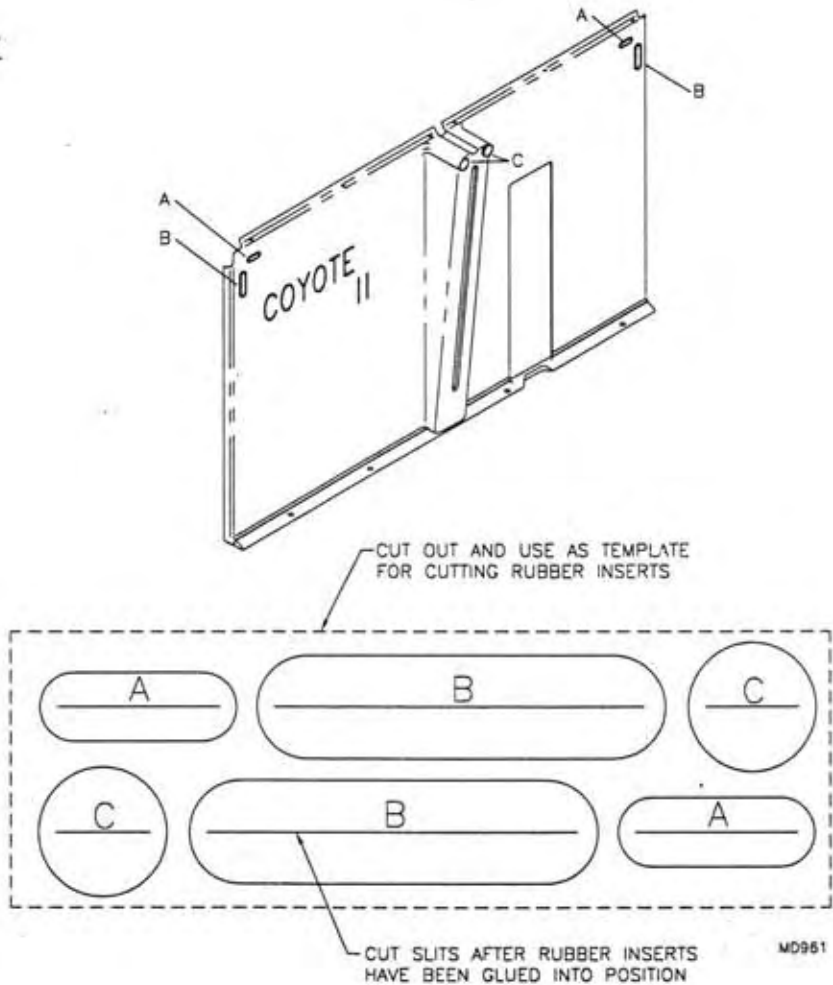
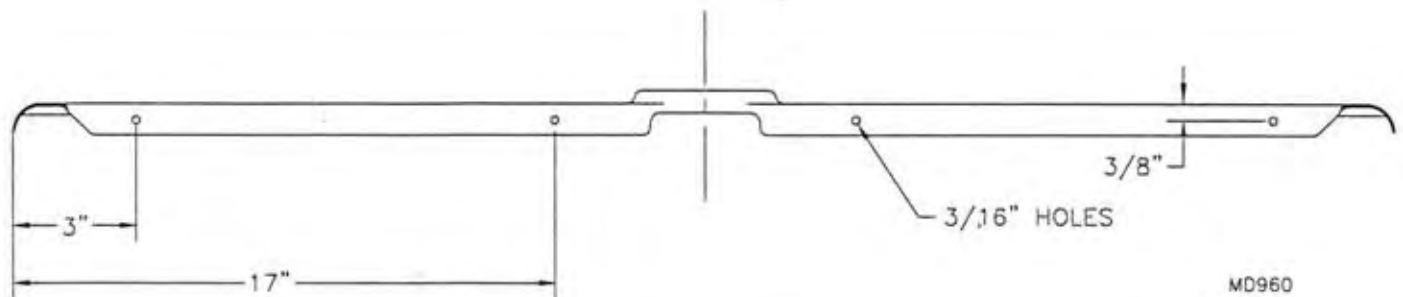


FIGURE 025N-07



8. Six #30 aluminum pop rivets are used to secure the top of the back panel. Locate these using tabs welded to the cage. The bottom of the back panel is retained to the S-3 midway crossing tube with 4 cushioned tube clamps. Locate and drill #11 holes as per **Figure 025N-08**. Bolt the extension tangs to the shoulder belt tangs. Set the back panel in place. It should fit against the S-3 with the panel overlapping the tubes approximately half way around. Tape the panel in place with masking tape.

**FIGURE 025N-08**



9. Set the baggage compartment panel in place. The panel overlaps onto the flange at the bottom of back panel. Tape in place.

10. Tape the seat close out and the control stick panels in place.

11. Locate and drill #40 holes in the bottom flange in the kick panels as per **Figure 025N-011**. Cut a clearance notch and attach the kick panel firewall retainer. See **Figure 025N-011A**. The plastic screw rivet used to attach the retainer expands in the 1/4" hole as it screws in. Tape the kick panels in place.

**FIGURE 025N-011**

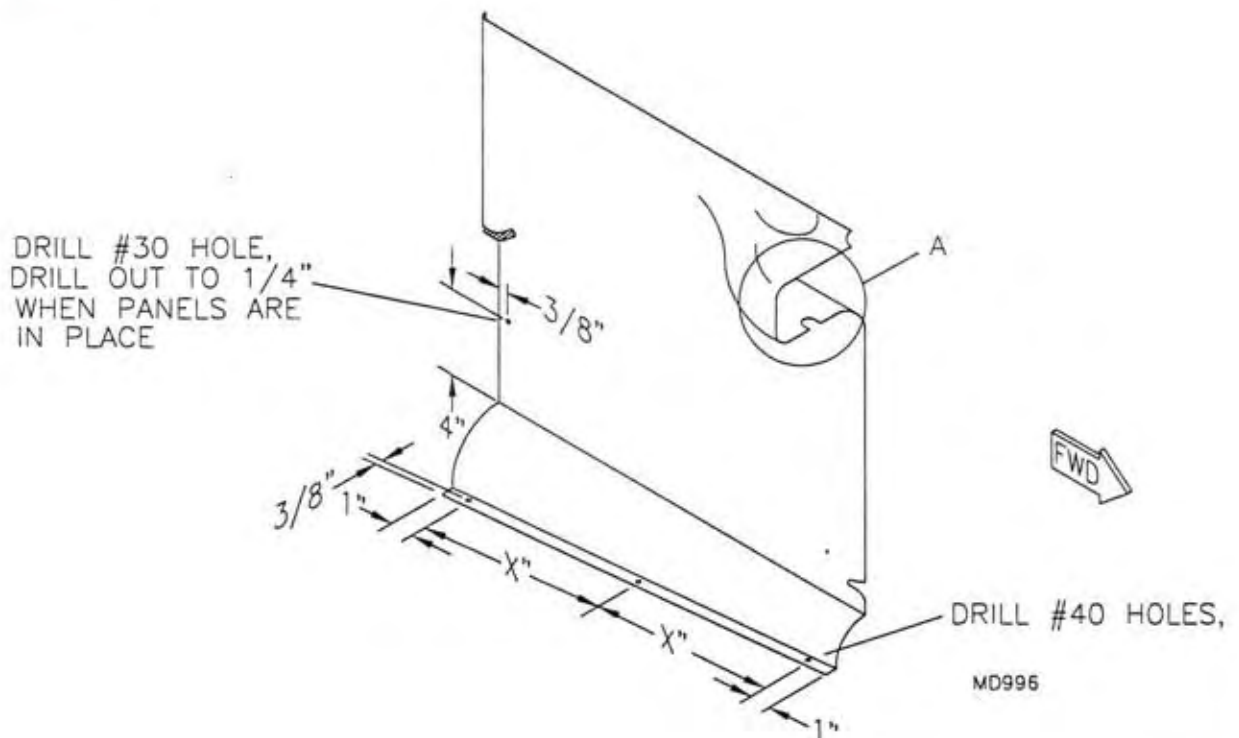
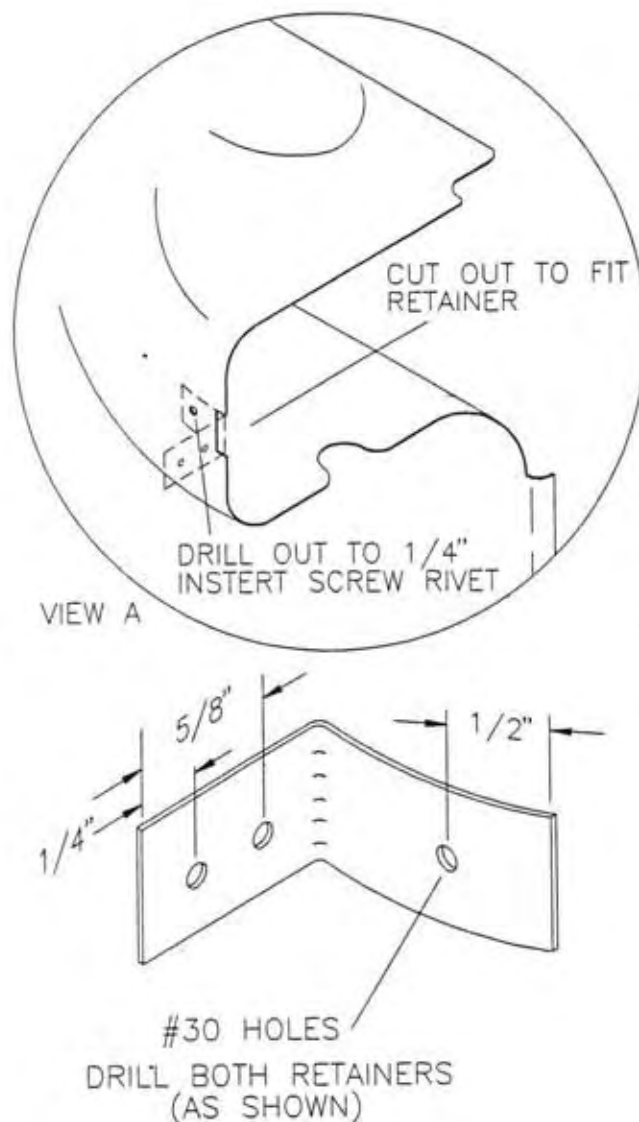


FIGURE 025N-011A

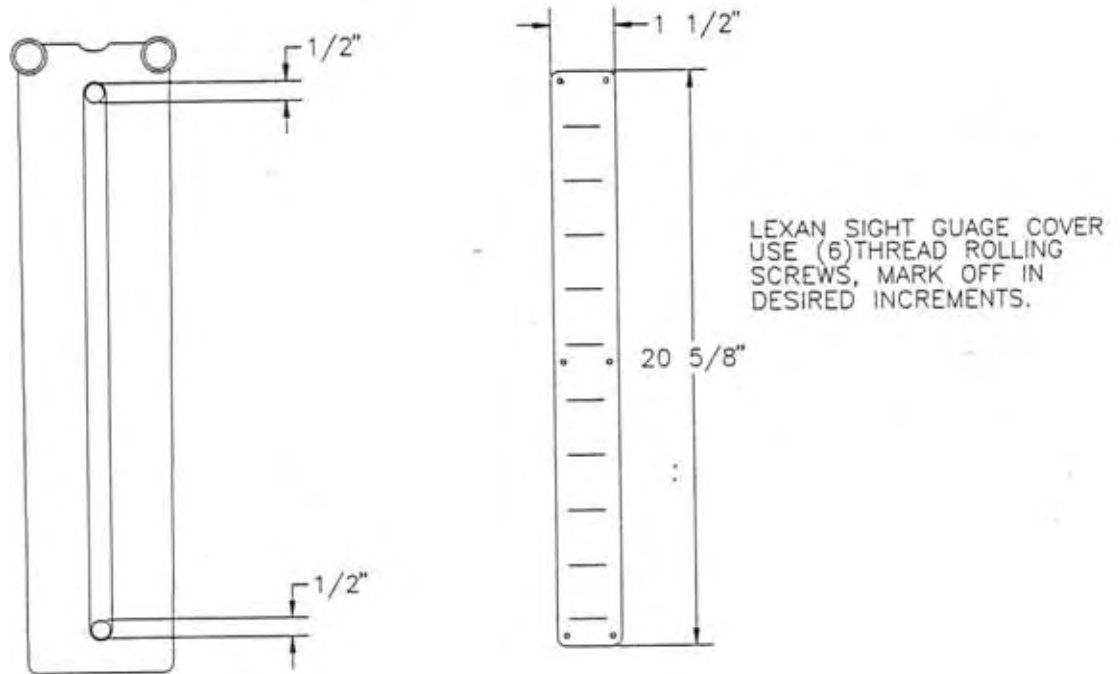


MD995

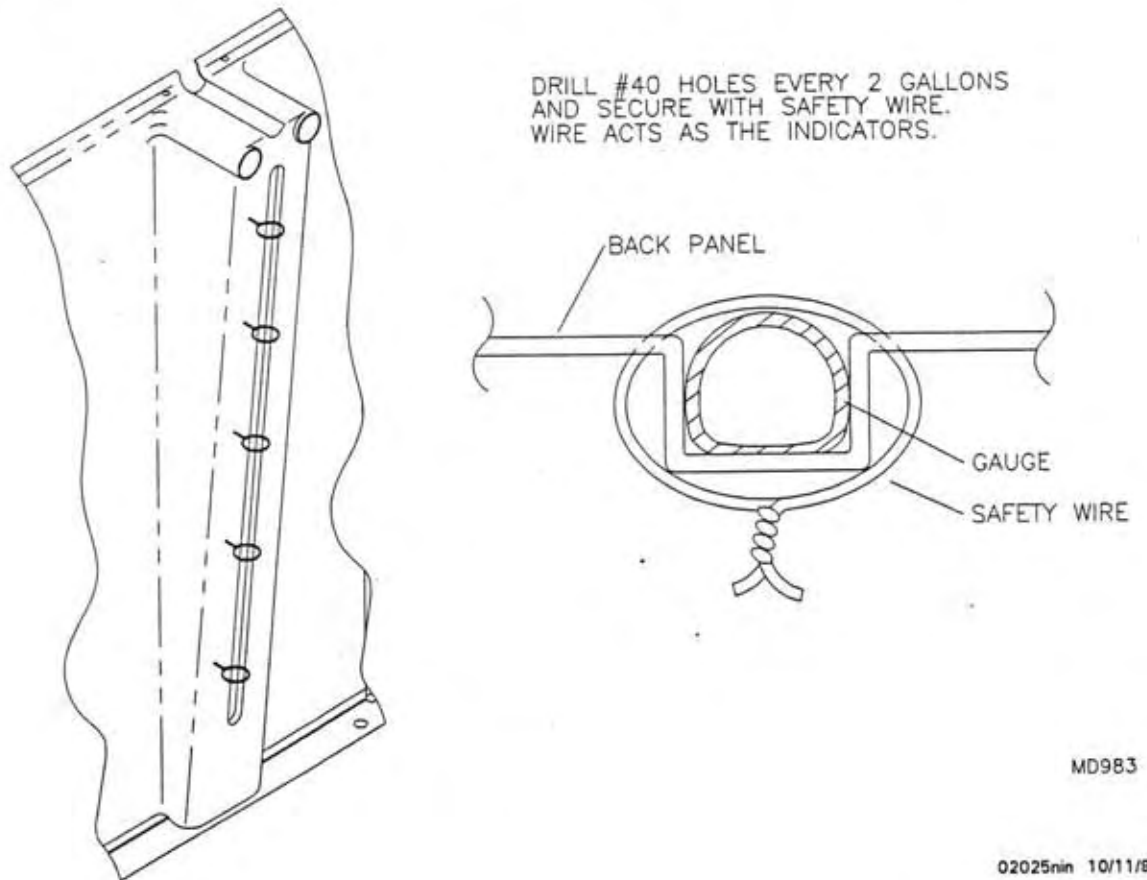
12. All the panels have now been trial fitted. From this you may tell if you need to fine tune the trimming. If the fit does not match the joggles with the other panels check for proper trimming. If properly trimmed the panels should fit together like a glove. Test fit the capture strips in the respective locations. Once they fit, mark the (4) holes on each side that will be used to rivet the strips in place. Refer to the parts list and locate the capture strip retainer. Carefully, cut the retainer into (8) 1/2" wide pieces using a fine coping saw or band saw. Release the lacing on the fuselage skin just enough to slip the retainers in place, so that they are centered on the marks on the skin. When the capture strips are installed for the final time, they will serve as a rivet backup plate to sandwich the fuselage skin. Remove all but the back panel from the cabin. With the back panel still in place, reach up from the bottom and behind, then punch the hole locations for the flap teleflex retainer.

13. If your plane is equipped with the 10 gallon auxiliary tank, drill a hole in the end of the sight gauge groove as per **Figure 025N-013**. The sight gauge line will be routed from the bottom of the tank to the bottom hole of the groove then out the top. To secure the sight tube in the groove two methods are used. 1. Cut a scrap piece of lexan 1 1/2" wide by 1/2" longer than the groove. Locate 6 #30 holes for the small screws in the edges of the lexan. See **Figure 025N-013**. Install over the sight gauge groove by transfer drilling #40 holes for the screws. When you fill the tank you can mark the lexan accordingly. 2. The alternate method uses a series of small holes and safety wire, see **Figure 025N-013A**.

**FIGURE 025N-013**



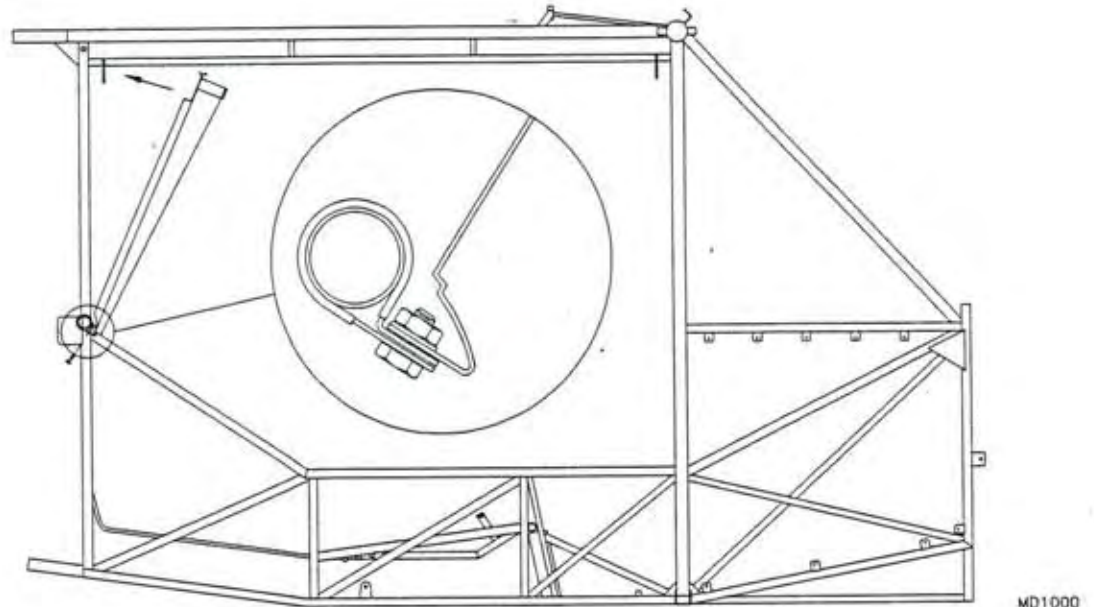
**FIGURE 025N-013A**





14. Install the two way acrylic foam tape to the back panels' outside edges. Do not remove the backing from the tape at this time. Finally, assemble the back panel to the S-3 by placing the 4 tube clamps over the S-3 middle crossing tube. Set the back panel in at a tilt to help access the 4 clamps. See Figure 025N-014 with the detail of cross section.

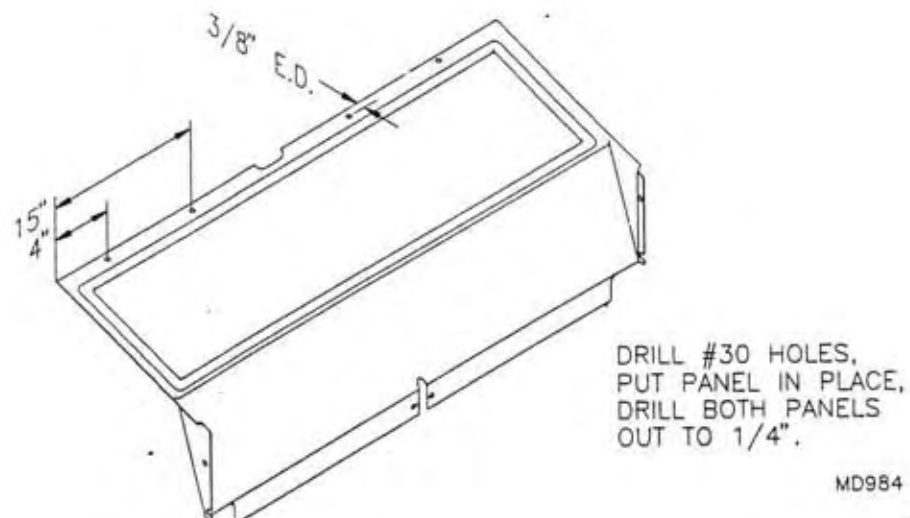
**FIGURE 025N-014**



15. Rotate the back panel into place and transfer drill the #30 holes into the S-3 top crossing tube. Tilt the panel out slightly and remove the backing from the foam tape. Press the panel tight against the S-3. Install the proper rivets into the top of the back panel.

16. Locate and drill the top flange of the baggage panel as shown in Figure 025N-016. Put the panel in place and drill through the back panel with a 1/4" bit. Remove the baggage panel.

**FIGURE 025N-016**

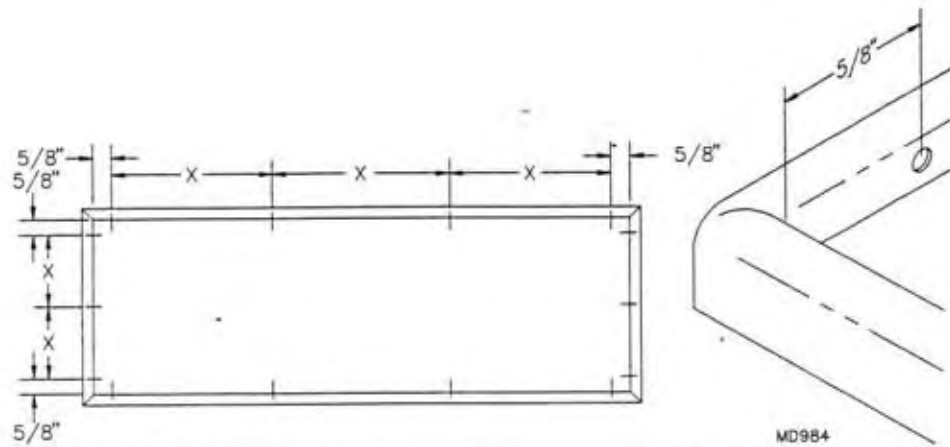


DRILL #30 HOLES,  
PUT PANEL IN PLACE,  
DRILL BOTH PANELS  
OUT TO 1/4".

MD984

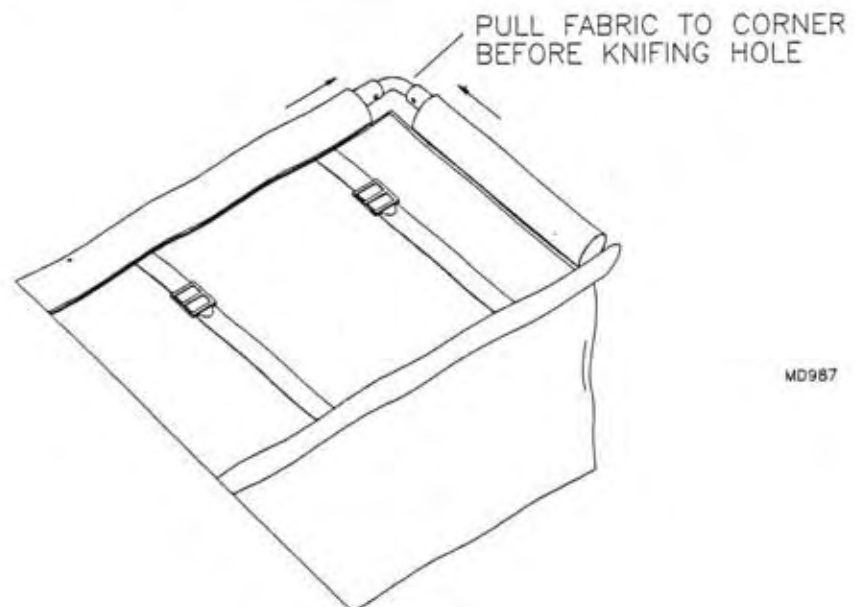
17. Cut the 1/2" aluminum tubes to length, (2) 37 3/16" and (2) 10 3/16". Connect the tubes together with the 90 degree plastic fittings and snap into place. Refer to **Figure 025N-017** for the location of the rivet holes to retain the tubes. After drilling and before removing, mark the tubes one thru four on the back side to know which tube goes where during final assembly.

**FIGURE 025N-017**



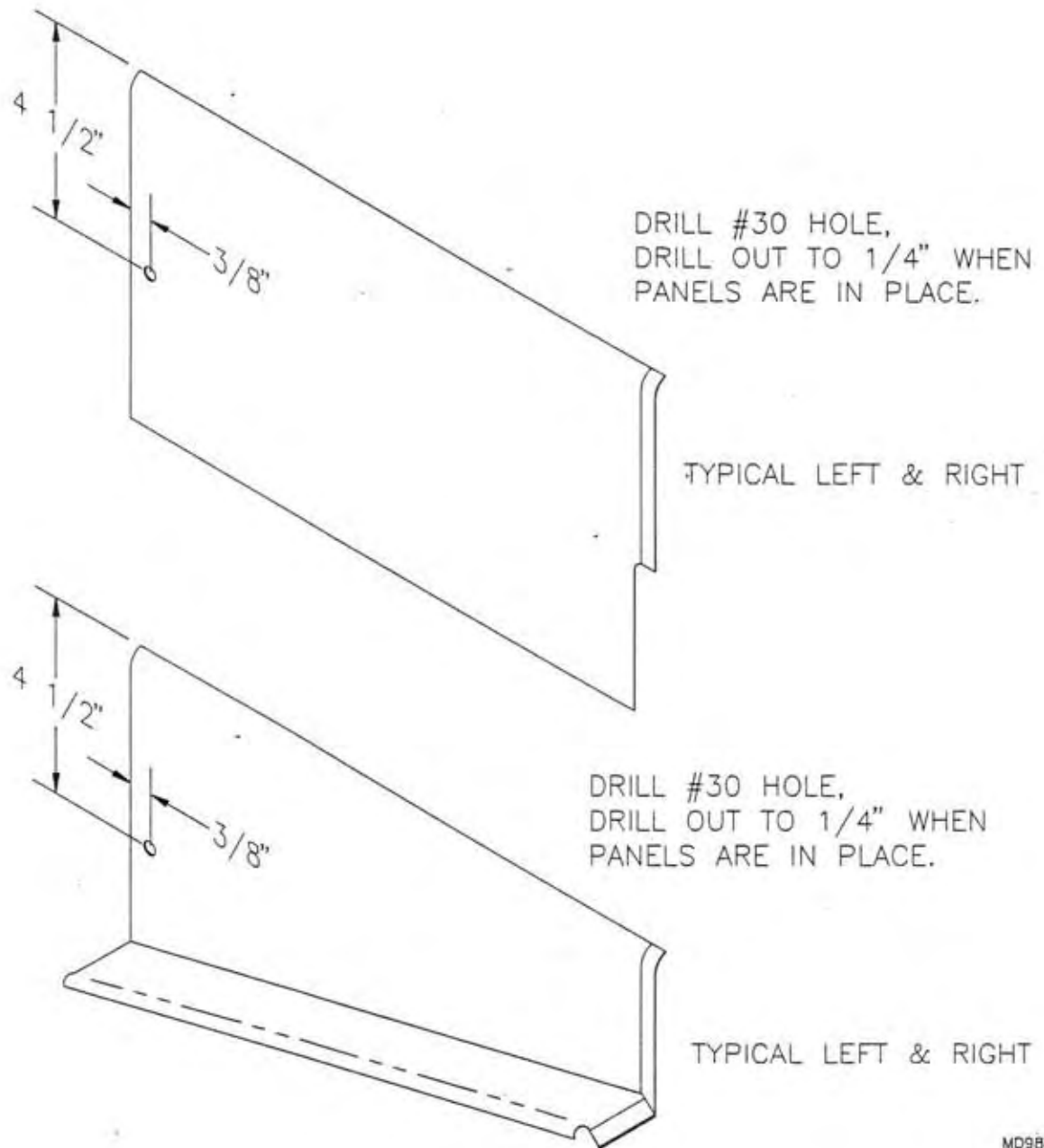
18. The baggage compartment is positioned with the zipper to the back. Slip the baggage tubes into the pockets sewn into the edges of the compartment. Pull the fabric into the corners. Locate the hole with a punch and cleco. This should stretch the fabric tight leaving no gap in the corners. See **Figure 025N-018**. Place the assembly into the grooves and rivet in place. When installing the compartment it is best to leave the corners clecoed, pushing in the middle sections first. Cleco the middle to the panel, then remove the corner cleco and push into the groove. Use an ice pick or prick punch to locate the rivet holes. Cut away the center panel to open the baggage compartment.

**FIGURE 025N-018**



19. Locate and drill the holes as indicated in **Figure 025N-019** for the proper type of seat panel. Install the seat side, drill the #30 holes out to 1/4" in both the seat side and baggage compartment panels. Install the screw rivet. Remove the flap lever and locate the flap mount bolt hole in the seat center panel. Drill the #30 side holes out to 1/4" and install the plastic screw rivets.

FIGURE 025N-019



20. Drill the proper holes in the control stick as shown in **Figure 025N-020**. For the front edge of the panel locate the holes for the existing floorboard bolts. They should have about 3/8" edge distance (ED). Bolt the panel in place. Drill the #30 side holes out to 1/4" and install the plastic screw rivets.

21. Set the kick panel in place with the edge slipped under the windshield "Z" strip. Drill into the floorboard #40. Be careful not to drill through the floorboard. Lift out the kick panel. Drill out the holes against the floorboard to #30. Set the kick panel back in place. Install the screws into the floorboard. A plastic screw is located on the kick panel AFT vertical edge. Drill the #30 hole out to 1/4" in both the kick and the control stick panels. Install the plastic screw rivets.

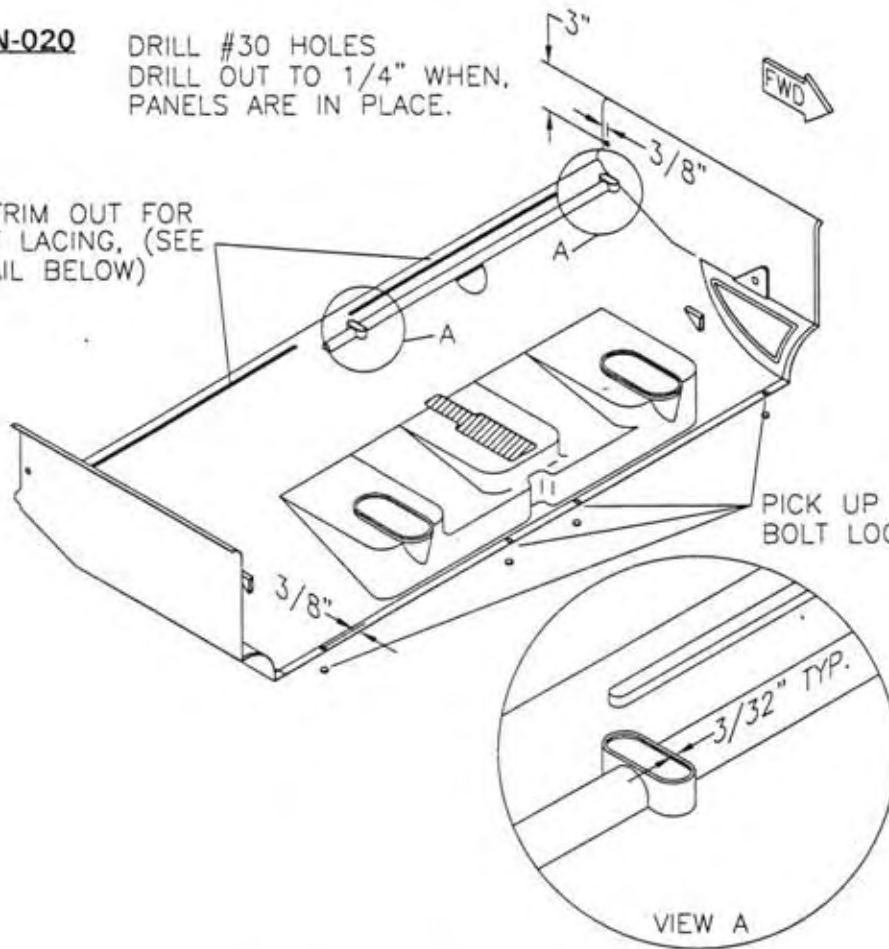
22. Press the aluminum tab attached to the kick front top corner against the firewall. Drill into the firewall and rivet the tab.

MD988

**FIGURE 025N-020**

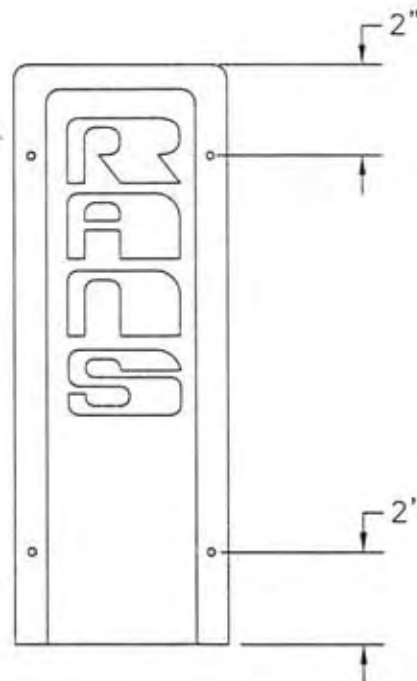
DRILL #30 HOLES  
DRILL OUT TO 1/4" WHEN,  
PANELS ARE IN PLACE.

TO TRIM OUT FOR  
SEAT LACING, (SEE  
DETAIL BELOW)



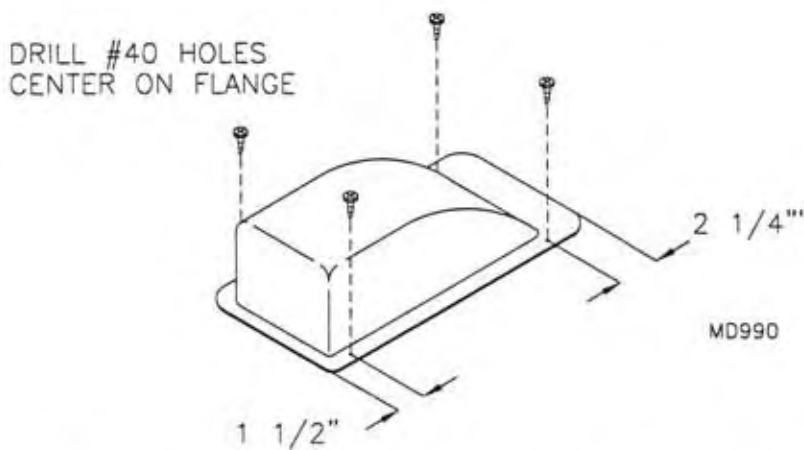
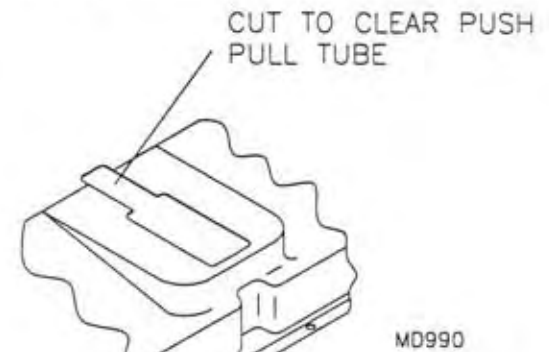
23. Locate the holes in the flap teleflex cover. Position and transfer drill into the back panel. Bolt on the teleflex retainer and route the flap cables. Safety clip the cables and install cover. See Figure 025N-023.

**FIGURE 025N-023**

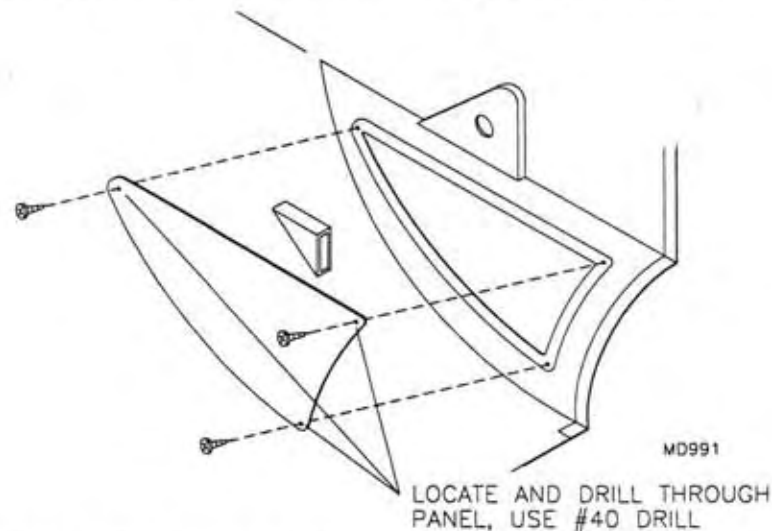


DRILL #40 HOLES  
CENTER ON FLANGE

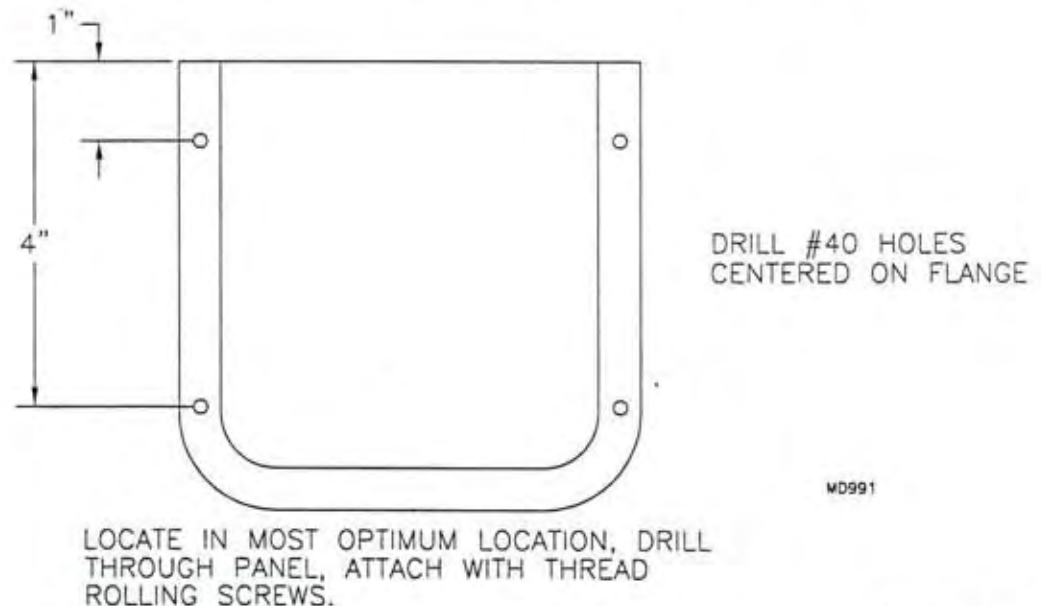
24. Drill #40 holes in the torque tube cover, position, drill and install the screws. See Figure 025N-024. **NOTE:** Cut out control stick panel to clear push pull tube, see Figure 025N-024A.

**FIGURE 025N-024****FIGURE 025N-024A**

25. Locate and drill the inspection covers as shown in Figure 025N-025. Drill and install the panels with screws.

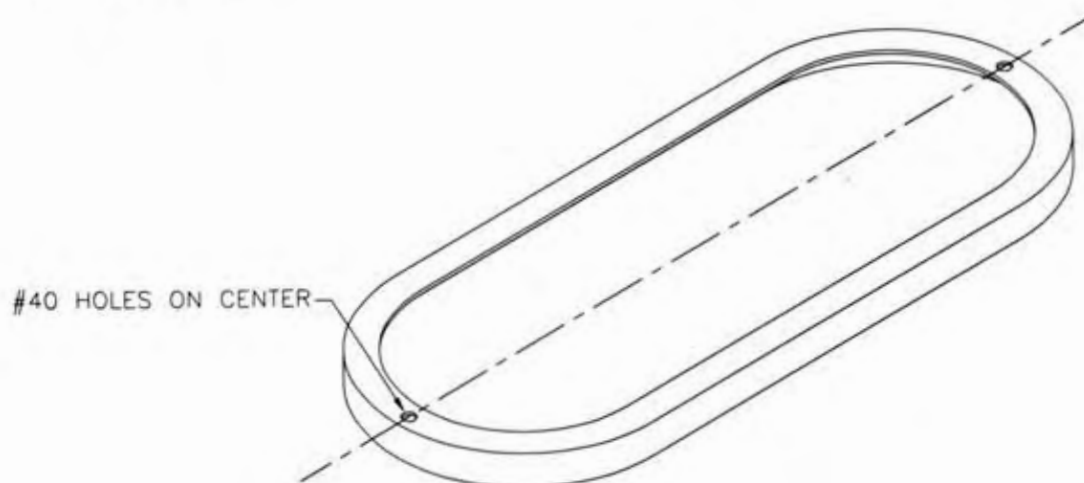
**FIGURE 025N-025**

26. The log book pocket is located by your preference, usually in the lower left side of the kick panel. Test fit the location prior to drilling and screwing in place. See Figure 025N-026.

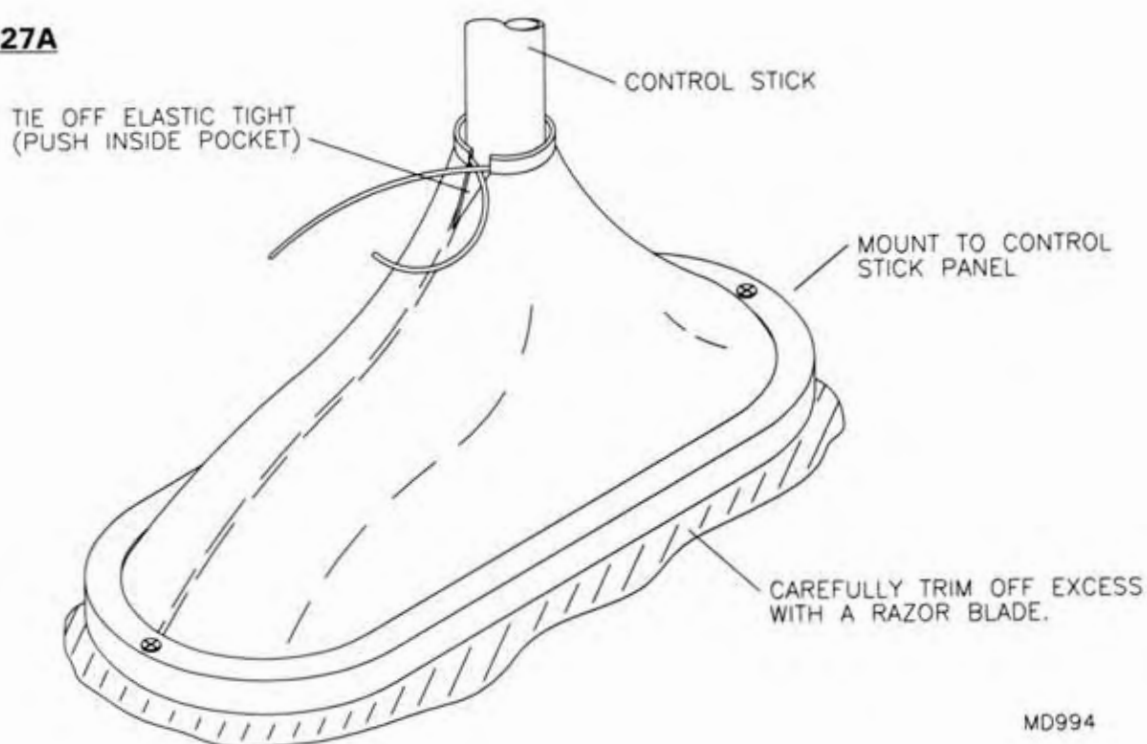
**FIGURE 025N-026**

27. Locate holes in the control stick boot retainer as shown in **Figure 025N-027**. Fit the control stick boots by placing the boots on with the seam AFT. The fabric of the boots should extend past the edge of the retainers by 1/4" to 1/2". Push the retainers down tight and drill. See **Figure 025N-027A**. Trim off the excess after installing the screws.

**FIGURE 025N-027**



**FIGURE 025N-027A**



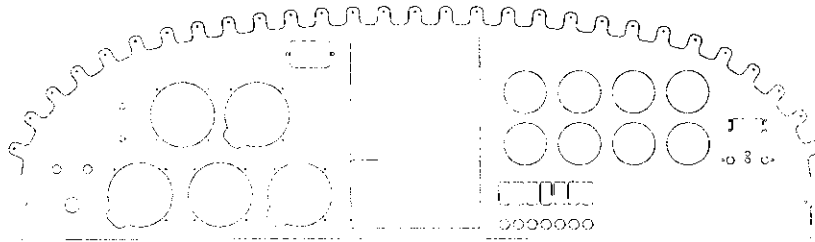
MD994

28. The formed aluminum capture strips are now ready to install. Place the strip over the proper edge and drill using the pilot holes. Make sure the outside holes are drilled into the capture strip retainers inserted earlier. Drill and rivet the inside, being careful not to drill through to the outside.

## OPTIONAL SUPER SIX INSTRUMENT PANEL ASSEMBLY FOR S-6ES

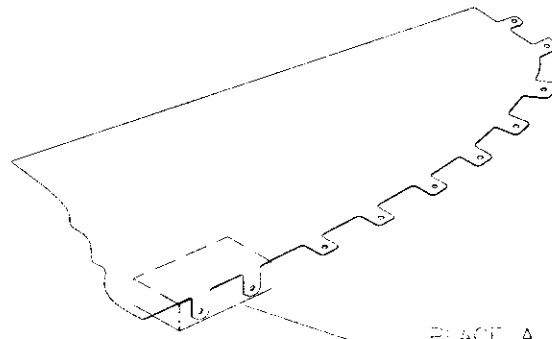
1. The instrument panel is provided as a blank. An Optional cut panel is also available as shown in **FIGURE 025P-01**. Otherwise, layout and cut the panel to your design. Debur and test fit the instruments before painting.

**FIGURE 025P-01**



2. Bend the tabs over 90 degrees on the top of the main panel. Bend the tabs to face **FORWARD**. Use a block of wood to back up the tabs for even bends. Press the tabs over with your finger. See **FIGURE 025P-02**.

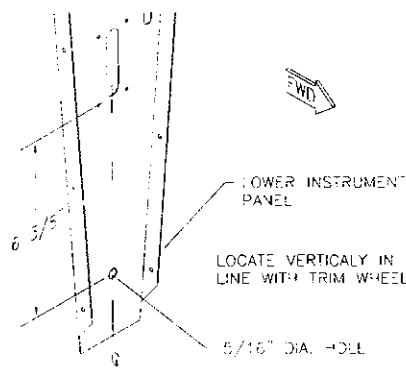
**FIGURE 025P-02**



PLACE A BLOCK OF WOOD ON EDGE TO FORM AN EVEN EDGE.

3. There are four tabs welded to S-2 for the stock S-6ES instrument panel. Remove the top tab on each side. Grind flush with tube. **IMPORTANT:** The tab is about 4 3/4" above the lower panel tab. This tab will not be present if ordered as a Super 6 option. **CAUTION:** Do not cut into the fuselage tube at S-2. Damage to the fuselage tube could weaken the fuselage cage.
4. Located on each lower corner of the main panel is a #30 hole. Use these holes to cleco the panel to the tab welded to the aft side of the S-2. Center the lower panel along the bottom of the main panel. Mark and drill #30.
5. **IF INSTALLING PANEL MOUNT TRIM:** Locate and drill a 5/16" hole in the lower panel as shown in **FIGURE 025P-05**. Cleco in the lower panel. The panel should attach to the aft side of the tab welded to the bottom carry through, and to the bottom edge of the main panel. Once the fit has been checked, remove the clecos, rivet and bolt as per the parts drawing.

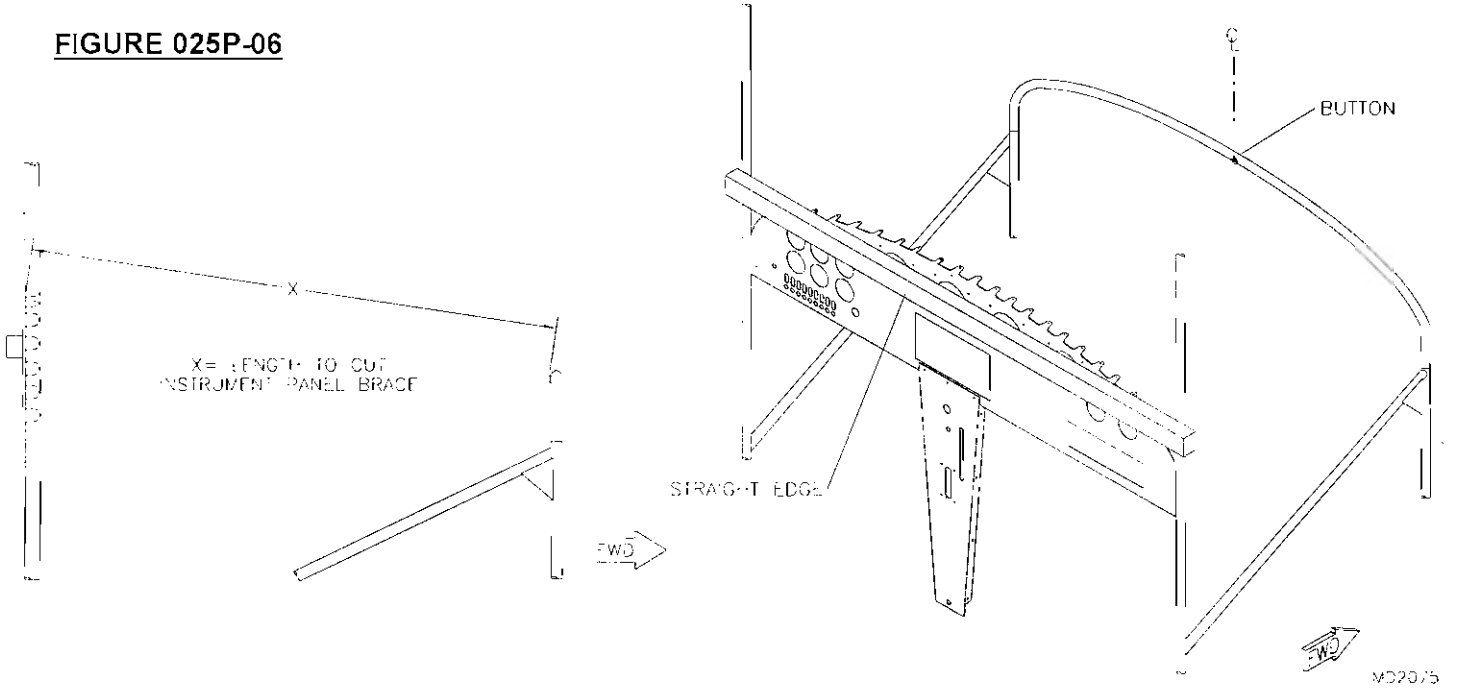
**FIGURE 025P-05**



MD1509

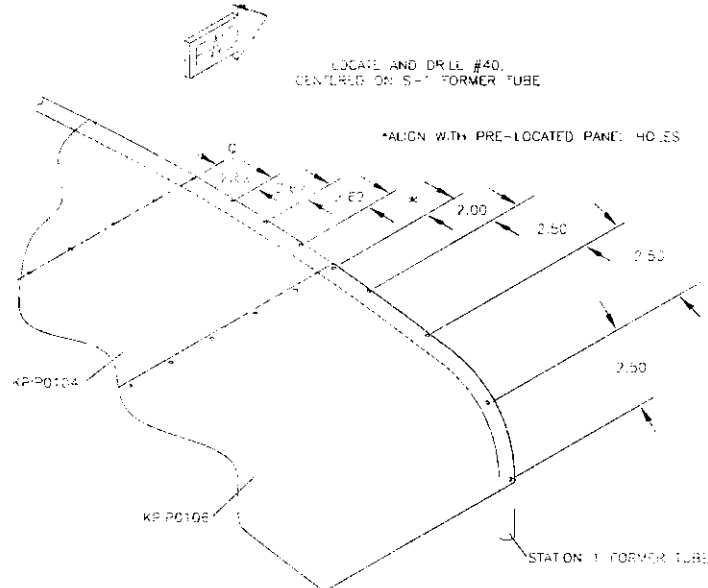
- Clamp a straight edge across the aft side of the main panel. See **FIGURE 025P-06**. Locate a "button" just above center on the aft side of the S-1 top former. Place the button so that the tube will be flush with the top of the S-1 top former. Measure between the panel and S-1 top former. Cut the tube to length. Install the panel brace by inserting the plastic plug into one end. Place this end against the panel. Install a rivet into the plug from the aft side of the panel. Place the forward end over the "button".

**FIGURE 025P-06**



- Place the center panel cover on top of S-1 and panel. The panel cover comes pre-drilled. Line up the center holes centered on the panel brace tube. Line up the front of the panel cover with the hole centered on the top of S-1. Tape or clamp in place. Transfer drill #40 all center holes.
- Pull the panel tight against the Instrument panel tabs and S-1. Reach under the main panel and mark or scribe the hole locations for the instrument panel tabs. **NOTE: A #40 hole finder may also be used.**
- Cleco the Outboard Panel Cover to the Center Panel. Drill the Instrument panel tab holes as before. Be sure the entire cover assembly is pulled down tight. Locate and drill forward panel cover holes per **FIGURE 025P-09**. Trim the forward edge flush with S-1, as needed.

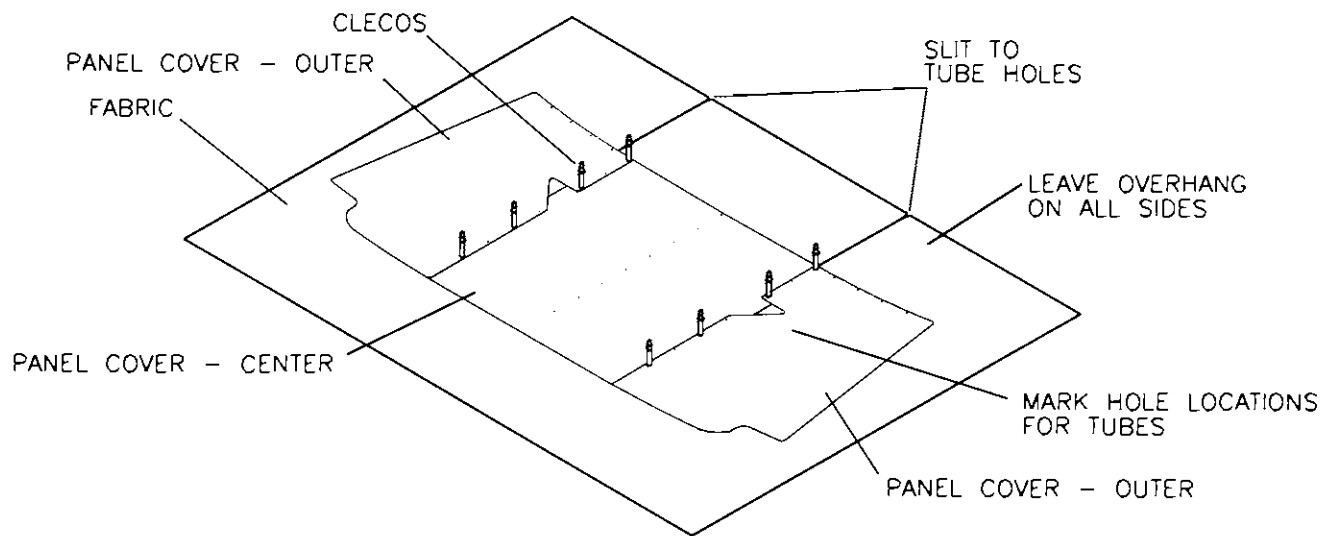
**FIGURE 025P-09**



MD5117



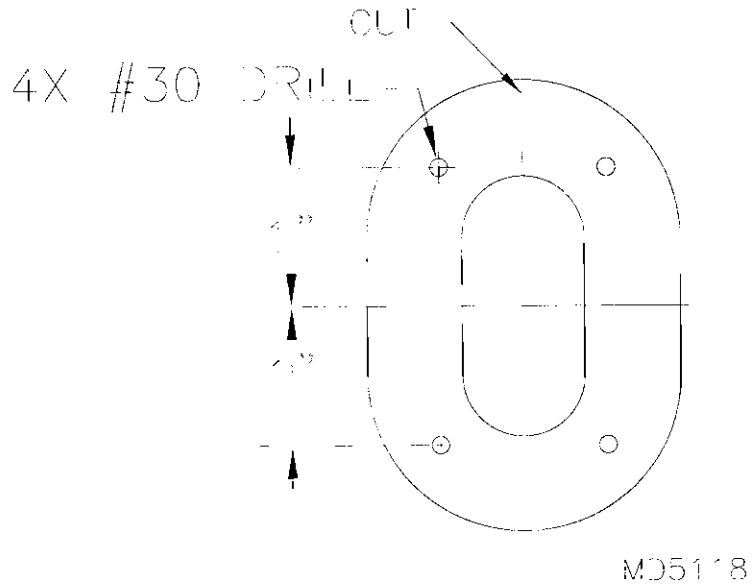
10. Locate the Bent Tang against the Instrument panel's bottom flange. Transfer drill #30 and Cleco. The long leg of the tang will retain the Outboard Cover's bottom edge. Transfer drill #30 to the Outboard cover and Cleco. Rivet during final assembly.
11. Set the panel covers aside. The panel cover and fabric covering will be installed after all the instruments are installed.
12. Install all instruments, controls, and wiring. Secure wires and control cables for heater, choke and throttle with plastic ties. Route wires and cables clear of rudder pedals and other moving parts. Try to do a neat job, even though everything will be hidden under the top panel.
13. Provided with your kit is a special fabric used to cover the top panel. It is highly recommended to use this fabric cover. It is made of a special sun resistant material. The fabric color is designed to allow the least amount of heat transfer to the instruments, as well as reduced glare and reflection. You simply can't do that with paint.
14. Unroll the fabric and lay it on a flat surface. The fabric is the same on either side. Lay the top panel cover over the fabric. Leave a generous amount of fabric overhang on all edges. Mark the location of the tube holes. Cut two slits in the fabric to the hole from the S-1. See **FIGURE 025P-14**. Roll up the fabric and store. Later after installing the top panel covers, use spray on contact cement to attach the fabric.

**FIGURE 025P-14**

MD925

15. Modify the Panel Close Outs per **FIGURE 025P-15**. Center the Close Outs on the fuselage tubes and panel cut outs. Drill #30 and Cleco. Rivet to the panels. If desired touch up the rivets with black paint to match.

**FIGURE 025P-15**



## OPTIONAL SUPER SIX WINDSHIELD ASSEMBLY FOR S-6ES

Lexan windshields scratch very easy. To get a longer service life from your windshield and other Lexan surfaces, we recommend a soft terry cloth and a cleaner made for plastic. We use a product called Brillianize. It is available from RANS or any large aircraft supply company. **IMPORTANT:** *The big no-no is NEVER dust off a windshield unless you have sprayed on some sort of fluid. Your dry dusting action will readily cut millions of fine scratches into the glazing, dimming its clear optics.*

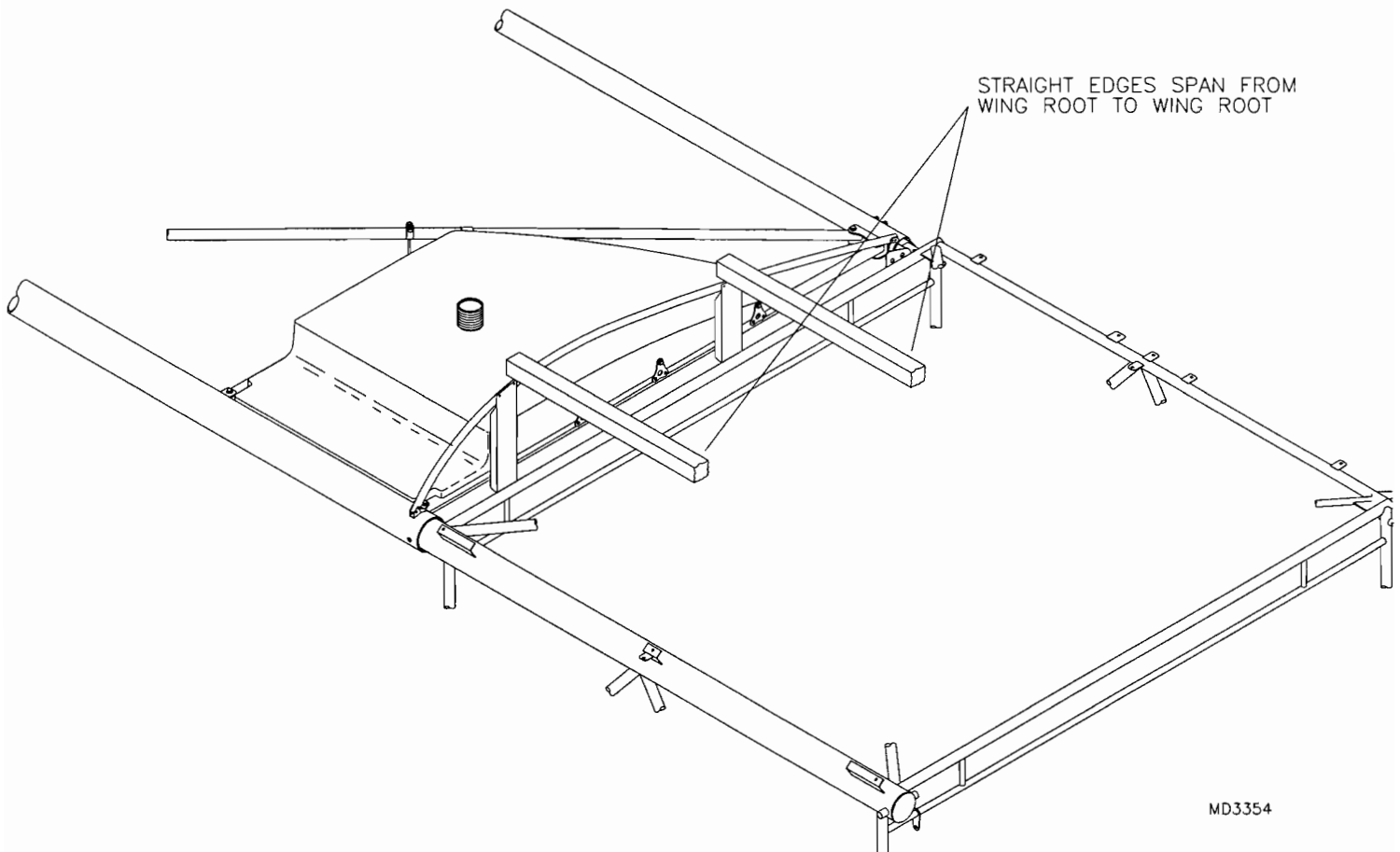
**NOTE:** *The wing structures must be complete (can be covered and painted) and attached to the fuselage prior to final installation of the windshield and skylight. However, the windshield and windshield deck may be fit up, before final assembly, without the wings, skylight, and skylight ribs installed.*

### **CAUTION: NEVER ALLOW FUEL TO COME IN CONTACT WITH LEXAN.**

If fuel is spilled on Lexan, spray with water or cleaner immediately to lessen the chance of crazing damage.

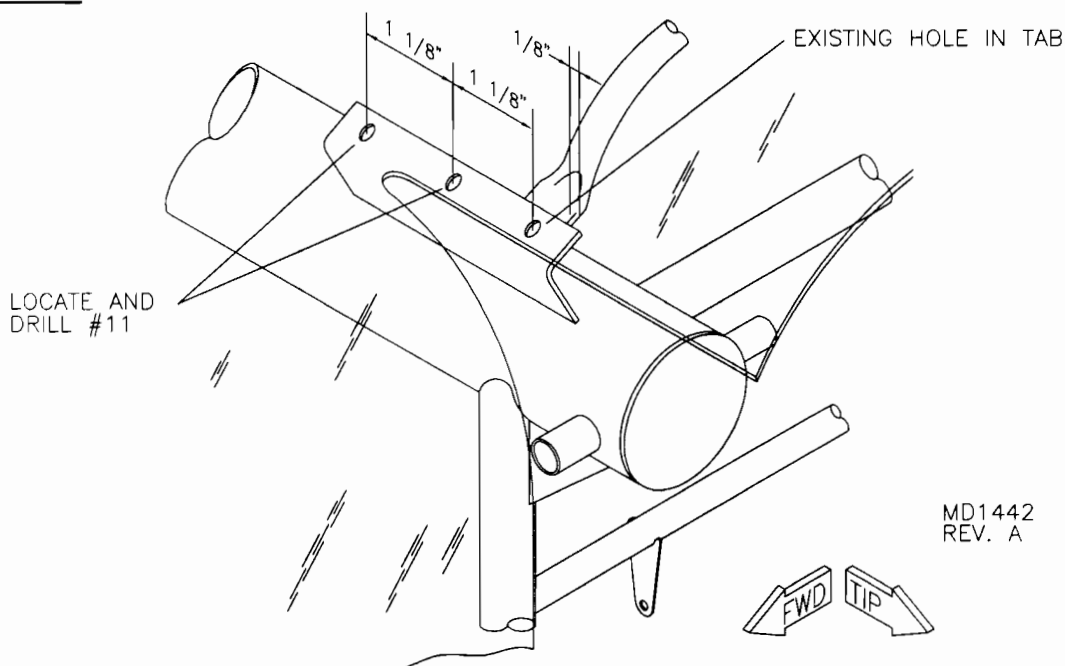
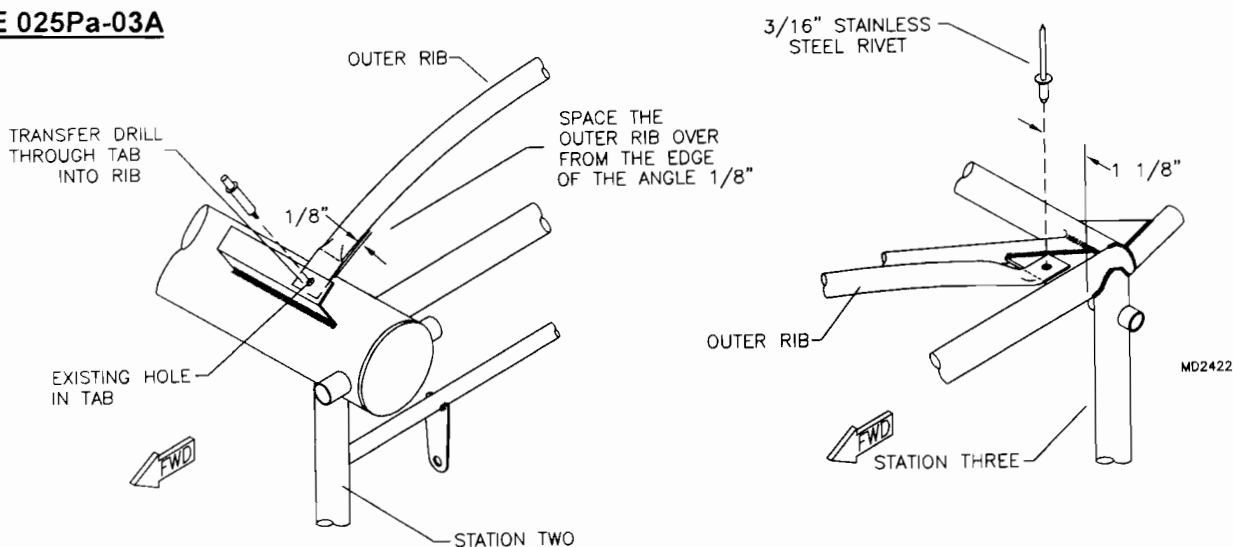
1. Collect all the parts shown on the part pages for the windshield. Extra care should be taken when working with Lexan. Lexan scratches easily and as much as possible of the protective plastic should be left in place until the aircraft is ready to be flown. The windshield will require some minor trimming. Lexan can be easily trimmed with aviation snips or by scoring and snapping off the piece to be trimmed. A sanding block with 80 grit paper works well for dressing up trimmed Lexan.
2. With the wings attached to the fuselage, position two straight edges from wing root to wing root as shown in **FIGURE 025Pa-02**.

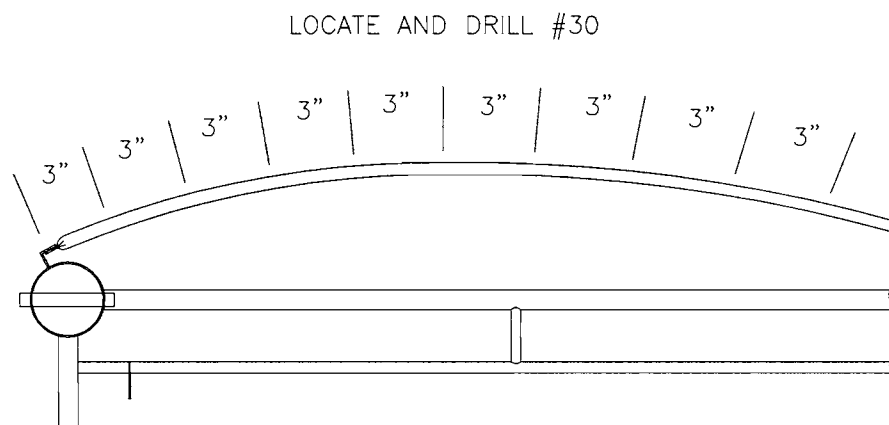
**FIGURE 025Pa-02**



MD3354

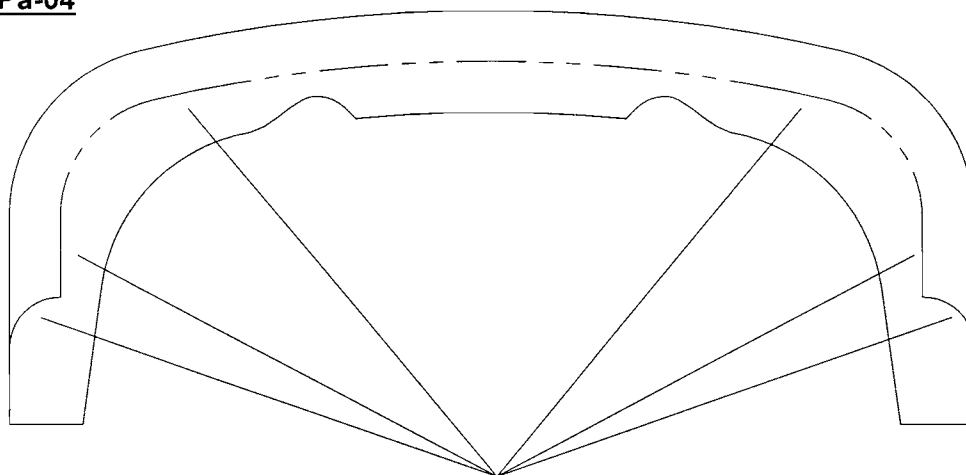
3. Drill the windshield tabs located on the leading edge spar carry-through as shown in **FIGURE 025Pa-03**. The outer skylight ribs mount to the topside of each tab through the outboard hole. **NOTE: Don't forget the plastic washers between the windshield and tabs upon final assembly.** Slip each rib into position under the tab and transfer drill through the carry through tab into the rib. Cleco the rib in place on **TOP** of the tab. Refer to **FIGURE 025Pa-03A**. The center rib is positioned under the center tab on the leading edge spar carry through and slips over the center tab on the station three top cross tube. Position the center rib and transfer drill through the forward tab into the rib and cleco. Locate and drill a #11 hole in the center of the flattened portion on the aft end of each outer rib. Push the aft end of each rib forward until they uniformly contact the straight edges. Some tweaking of the ribs may be required. With the ribs contacting the straight edges transfer drill through the rib into the steel gusset on the fuselage and rivet. Refer to **FIGURE 025Pa-03A**. Remove the center rib from the aft mount tab. Hold the rib under the tab and push forward until contacting the straight edges. Transfer drill through the tab through the rib. Reposition the rib over the tab and rivet. **NOTE: Do not rivet the forward ends of the outboard ribs until the windshield has been installed.** Locate and drill the holes on top centerline of the rib as shown in **FIGURE 025Pa-03B**. **IMPORTANT: Do NOT drill completely through the ribs.**

**FIGURE 025Pa-03****FIGURE 025Pa-03A**

**FIGURE 025Pa-03B**

MD2422

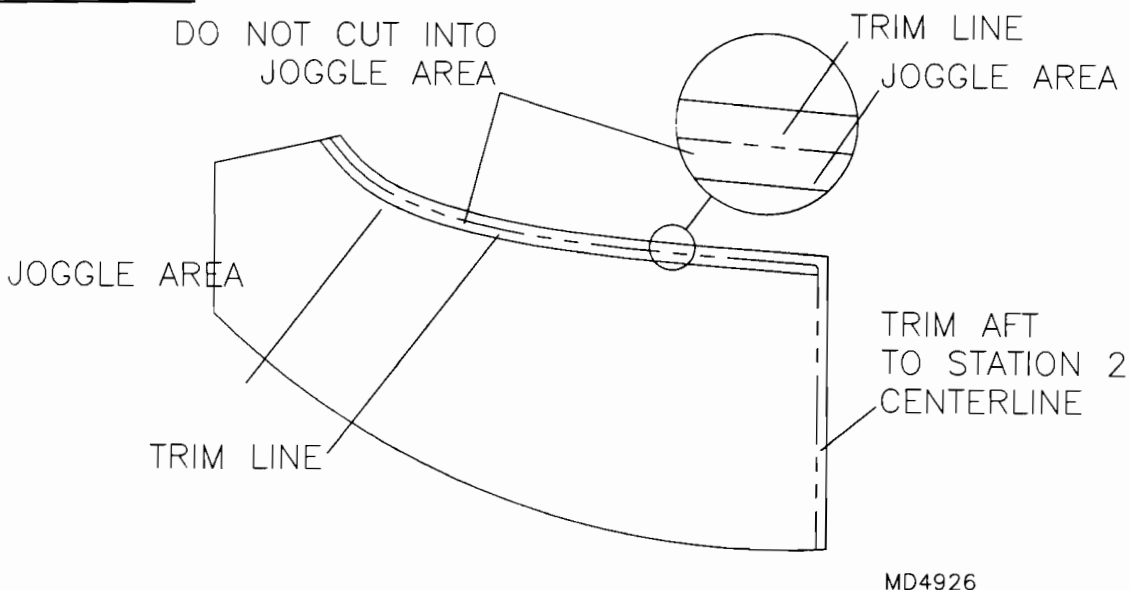
4. The fiberglass windshield deck is supplied untrimmed. Trim on the trim lines per **FIGURE 025Pa-04** and **FIGURE 025Pa-04A**. **IMPORTANT: Do NOT trim off the raised joggle area.** Place the deck onto the aircraft by slipping it over the S-1 top formers. The deck should fit nicely onto the former. Align the top aft edge of the deck flush with the bottom of the instrument panel tab. See **FIGURE 025Pa-04B**. Clamp the deck in place along the top former and secure the aft edge against S-2. **HINT: To prevent scratching the frame, wrap tape on the jaws of the clamps.** Center cowling hold down along top of firewall, sandwiching windshield deck between. Clamp cowling hold down strip in place, flush with top of windshield deck. Evenly space and drill five #30 holes in cowling hold down strip, maintaining proper edge distance. Be certain hole locations allow rivets to pass through windshield deck, into firewall's top former tube. Refer to firewall section for hole locations in cowling hold down strip. **NOTE: The windshield hold down strip is not installed as shown on firewall drawing when installing Super Six cowling/windshield.**

**FIGURE 025Pa-04**

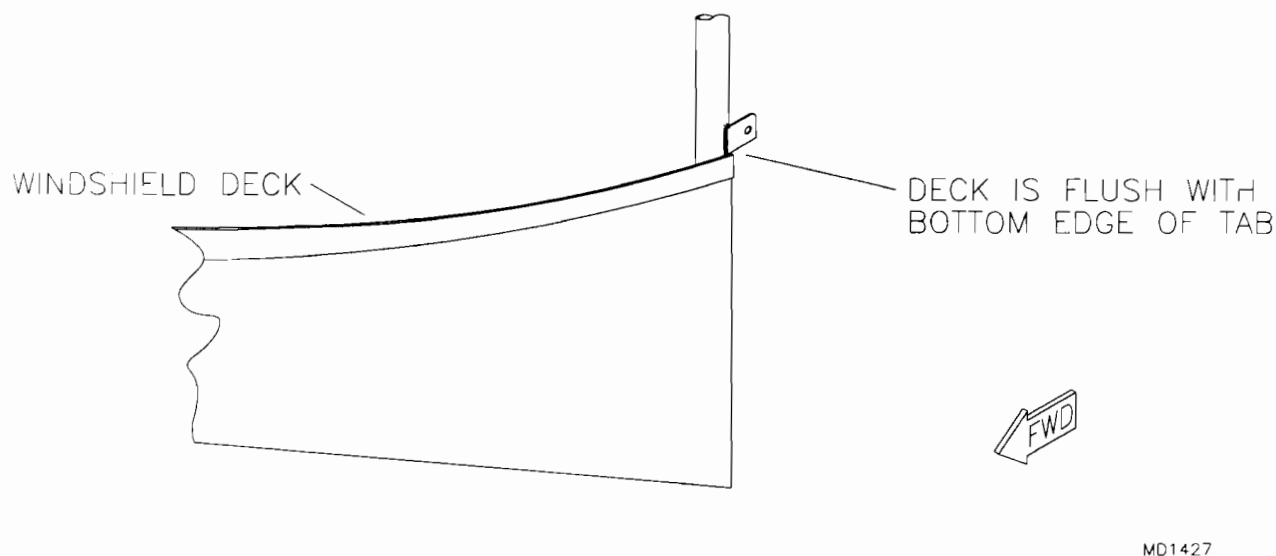
TRIM LINE

VIEWED FROM FWD SIDE

MD4926

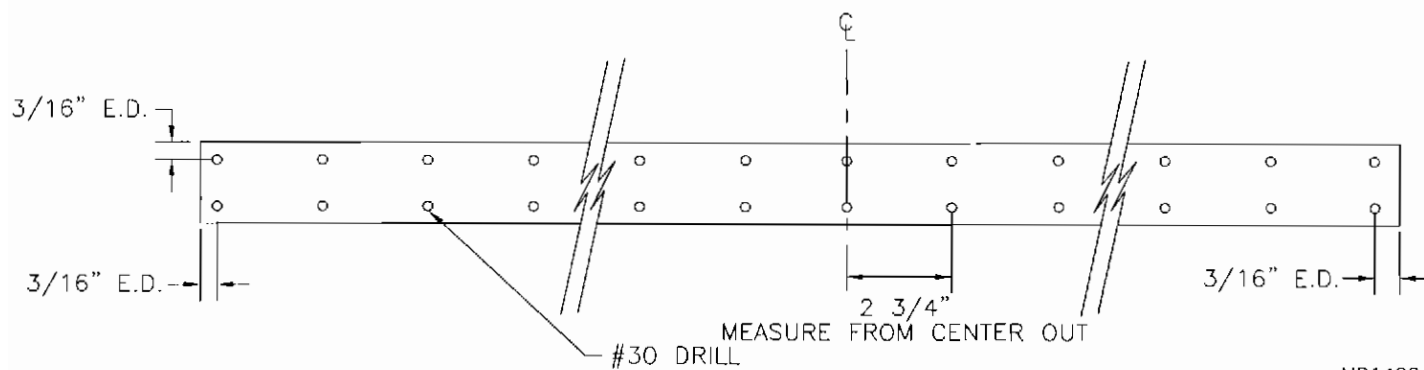
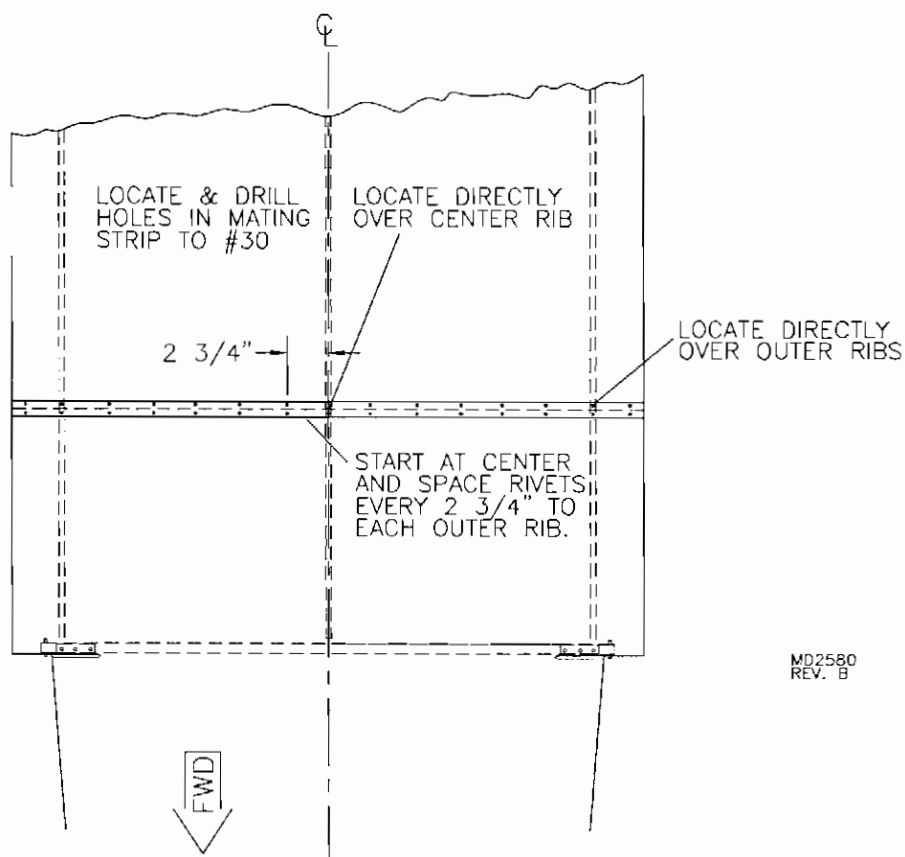
**FIGURE 025Pa-04A**

VIEWED FROM LH SIDE

**FIGURE 025Pa-04B**

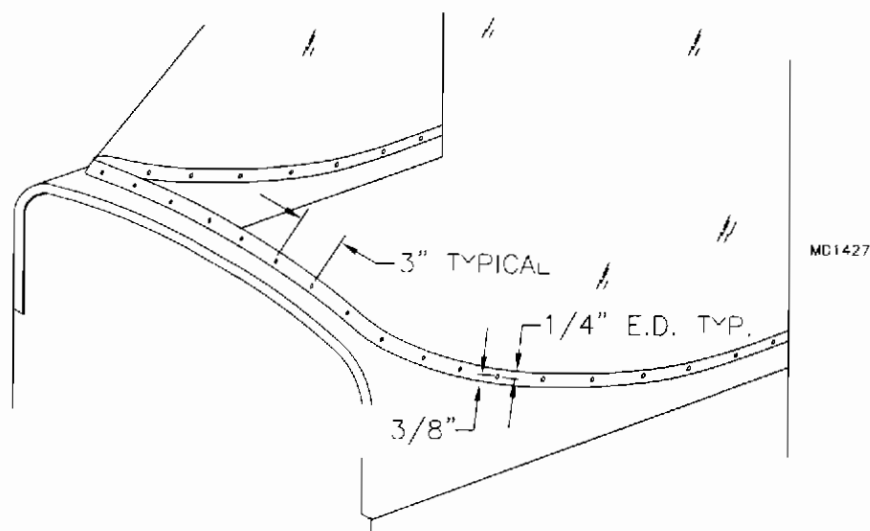
5. Locate and install windshield deck retainer strip on diagonal between S-1 and S-2. Clamp in place and locate seven #30 holes; cleco after drilling.
6. The windshield and skylight panels are joined together with two mating strips as shown in **FIGURE 025Pa-06**. Note that the center set of holes should be located to pick up the center rib, as well as the corresponding holes to the outer skylight ribs. Lay the windshield and skylight on a clean flat surface. Butt the skylight to the windshield. Center the top and bottom mating strips on the windshield and skylight seam. Using the pre-drilled holes as a guide, transfer drill through the mating strips and windshield and skylight. Cleco as you go. With all holes drilled, remove the mating strips and deburr. Drill out the windshield/skylight holes to #28. The mating strips may be painted or left as is. Run a small bead of silicon along the holes in the mating strips and rivet the strips to the windshield and skylight.

FIGURE 025Pa-06

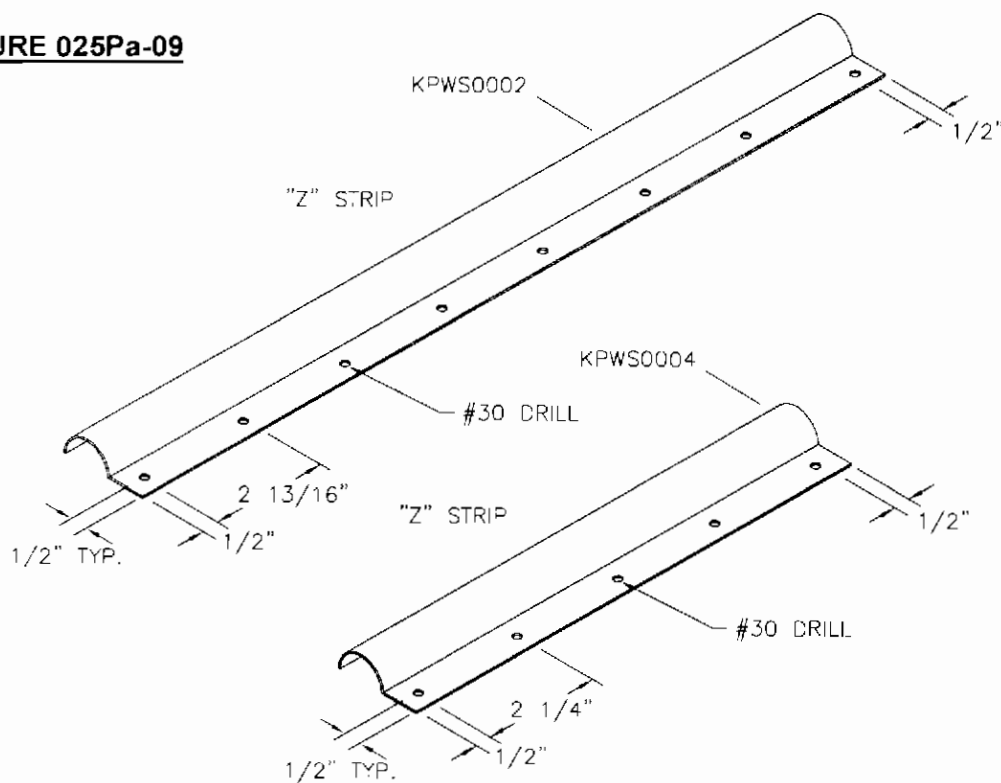


7. The windshield is supplied pre-cut, slightly oversized to create an overlap. Lay the windshield/skylight in position on the fuselage and ribs. There is a #11 hole drilled on each side of the windshield. Cleco the windshield in place through these holes and into the corresponding holes in the windshield tabs on top of the carry through. Clip the windshield in place **inside** the windshield deck. Push on the aft edges of the windshield to move the windshield tightly into place against the inside of the windshield deck. Clamp in place. The windshield should not contact the instrument panel top cover. It may be necessary to trim the lower end of the windshield to gain clearance. Pull the sides down to contour around the structure and clamp or tape in place. Check for an even amount of overhang on each side and if the Lexan is down against all edges. Re-position and clamp as required. Peel back a small area of the protective plastic around the windshield tab. With the skylight centered, drill through the windshield into the holes in each tab and cleco in place.

8. Measure off the firewall to determine the center of the deck. With the windshield clamped securely in place, tight against the inside of the deck, drill through on center line. Place holes with a 1/4" E.D. See **FIGURE 025Pa-08**. Layout 3" rivet spacing around the windshield deck off the center line. Make sure the windshield stays tight against the windshield deck and is clamped tight to the door post. Trim the lower end of the windshield 3/8" below the holes. **HINT:** Mark around the top edge of the windshield deck with a marker, measure down 5/8" and trim.

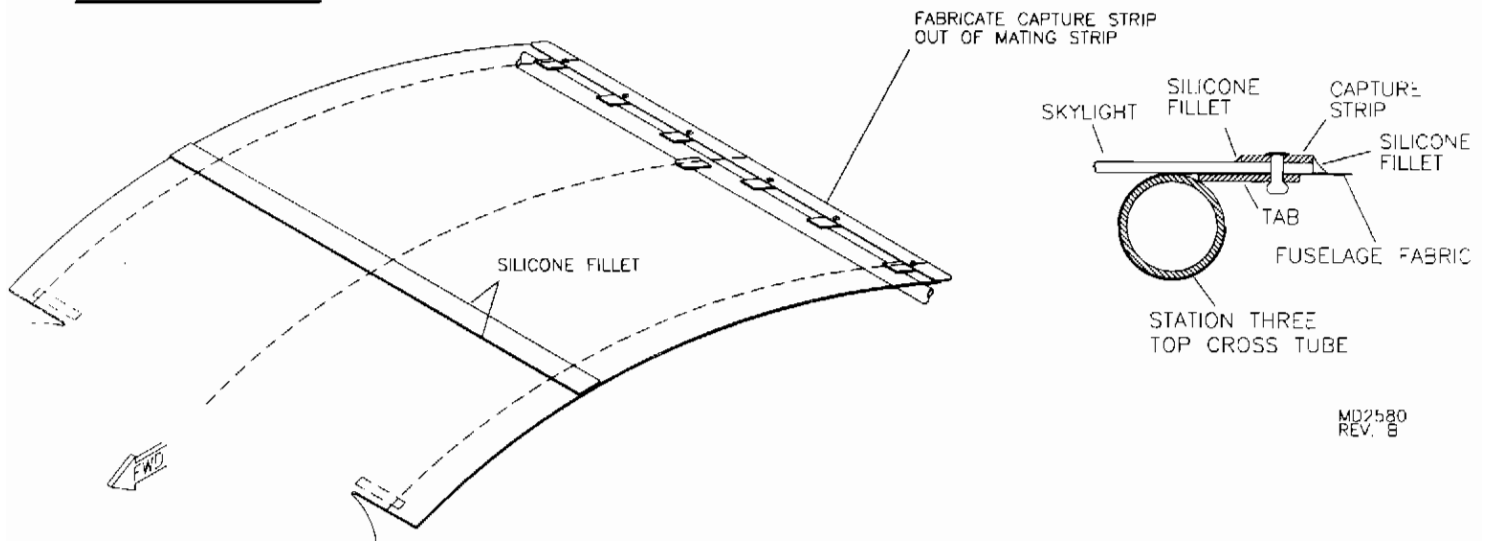
**FIGURE 025Pa-08**

9. Locate and drill the "Z" strips as shown in **FIGURE 025Pa-09**. Place the "Z" strips on the inside of the windshield. Position so that the flanges are against the windshield and centered up and down on the vertical S-2 tube. Press the windshield flat against the "Z" strips with a board or scrap piece of lumber. Using a #30 bit, transfer drill through the pre-drilled holes in the "Z" strips through the windshield. Cleco as you go. Repeat for the aft side of the windshield deck.

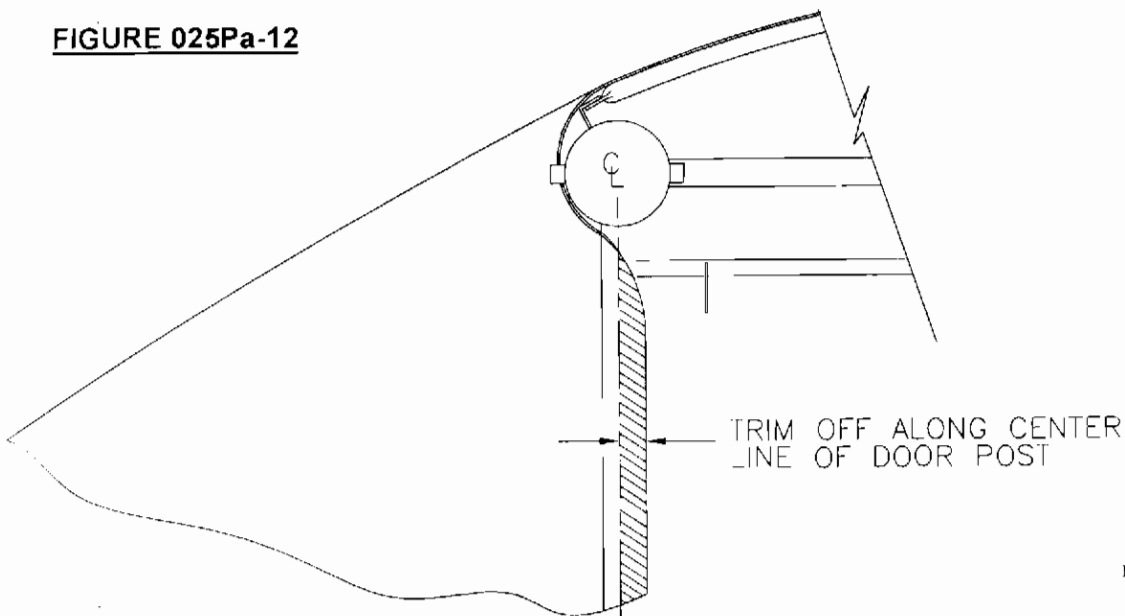
**FIGURE 025Pa-09**



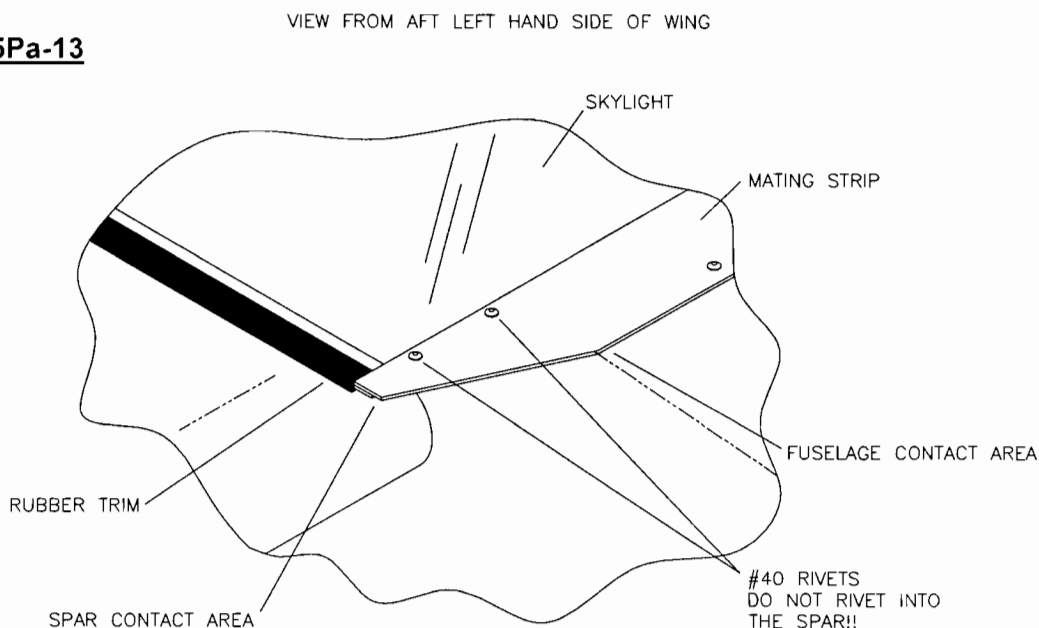
10. Mark where the outer and middle ribs lay under the Lexan with a marker. Trim the protective coating out of these areas. With the coating removed, the rib holes are visible. Using a #30 drill bit and starting at the forward end of each rib, transfer drill through the skylight at each hole location in the ribs. The skylight should fit tight against the ribs with no puckers or bulges.
11. Use the third skylight mating strip supplied to fabricate an aft capture strip to attach the skylight to the S-3 fuselage tabs shown in **FIGURE 025Pa-11**. Center the mating strip on the fuselage and the S-3 tabs. The capture strip should be flush with or slightly overlap the aft end of the skylight. Transfer drill #30 and cleco in place.

**FIGURE 025Pa-11**

12. Use masking tape to mark the trim line on the AFT edge of the windshield and windshield deck at the S-2 vertical side tubes. Mark and trim so that the aft edge of the windshield and deck is 1/32" forward of centerline of the door frame tube. Refer to **FIGURE 025Pa-12**.

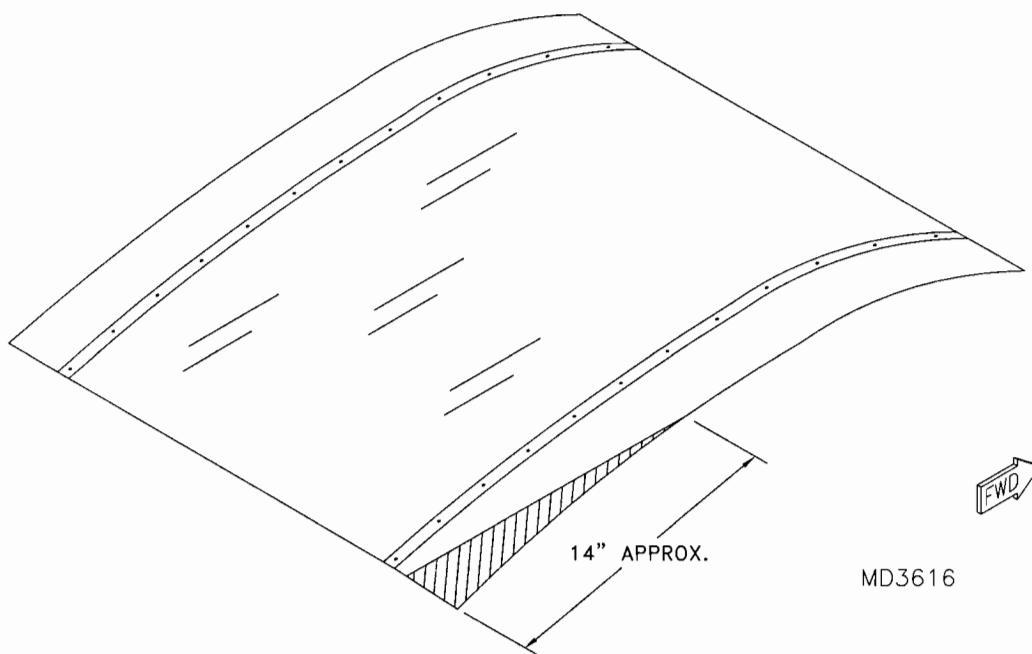
**FIGURE 025Pa-12**

13. Mark and trim the aft outboard edges of the skylight and capture strip as shown in **FIGURE 025Pa-13**. During final assembly, place a #40 rivet near, but **NOT** into the aft spar to hold the capture strip tight against the sky light.

**FIGURE 025Pa-13**

MD4927

14. Near the aft outboard edge, the skylight may not fit tight against the wing. Bend the skylight as shown in **FIGURE 025Pa-14**. **NOTE: Be careful not to over bend.** This will allow the skylight to lay firm against the wing. To do this after the plane is completed and flying is possible, but does require wing removal. Clamp the skylight between two bars or angles of steel. Pad the bars with masking tape to protect the skylight. Use this as a portable bending brake. Bend the skylight a little past the angle needed. Fine tune the bend to press against the wings once they have been installed. **NOTE: The aft capture strip will need to be bent to match.**

**FIGURE 025Pa-14**

MD3616

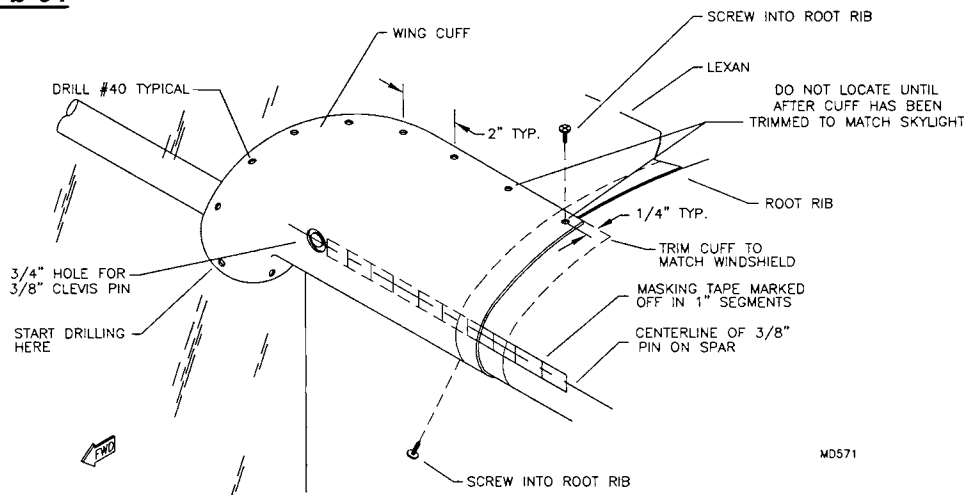
15. Remove the windshield. Drill out all holes, in the Lexan only, to #28 and debur. The "Z" and Mating Strips may be painted or left as is.
16. Install the rubber edging along the outer edges of the skylight. Use a small amount of cyanoacrylate glue (Permabond, super glue, etc.) to retain the edging in place. Do not glue the forward end until the wing cuffs are installed. During final assembly install the windshield and rivet. **NOTE:** *Place the plastic washers between the windshield tabs on top of the carry-through, inboard of the outer ribs.*
17. Apply a small fillet of clear silicon seal to the edge of the mating strip, aft capture strip, fuselage and windshield/skylight junction. **HINT:** *Apply tape flush with the edge of the metal strips. Place tape about 1/8" from the metal strips on the Lexan.* Clean Lexan and apply silicone seal and form into a fillet with your finger. Remove tape and allow silicone to dry.

## INSTALLING THE WING CUFFS

**PLEASE NOTE:** Before the wing cuffs can be installed the wings must be on the plane.

1. Trim the cuffs to fit. See **FIGURE 025Pb-16**. Before installing the cuffs place a strip of masking tape on the spar at least 8" long on the spars centerline starting at the spar's 3/8" pin. Mark off the tape in 1" segments from the exact center of the pin. The tape will serve as a way of marking on the cuff where to drill for the 3/4" diameter pin access hole. See **FIGURE 025Pb-01**. To locate the pin under the cuff, measure onto the cuff using the tape as a reference. Because of the springy nature of the plastic, the cuffs are a bit tricky to fit up to the windshield. **HINT:** The trick is to start drilling and installing clecos from the **BOTTOM** to the top. A total of 9 rivets are used to retain the cuff to the windshield. Locate and mark for 9 rivets, along the edge with about a 1/4" edge distance.

**FIGURE 025Pb-01**



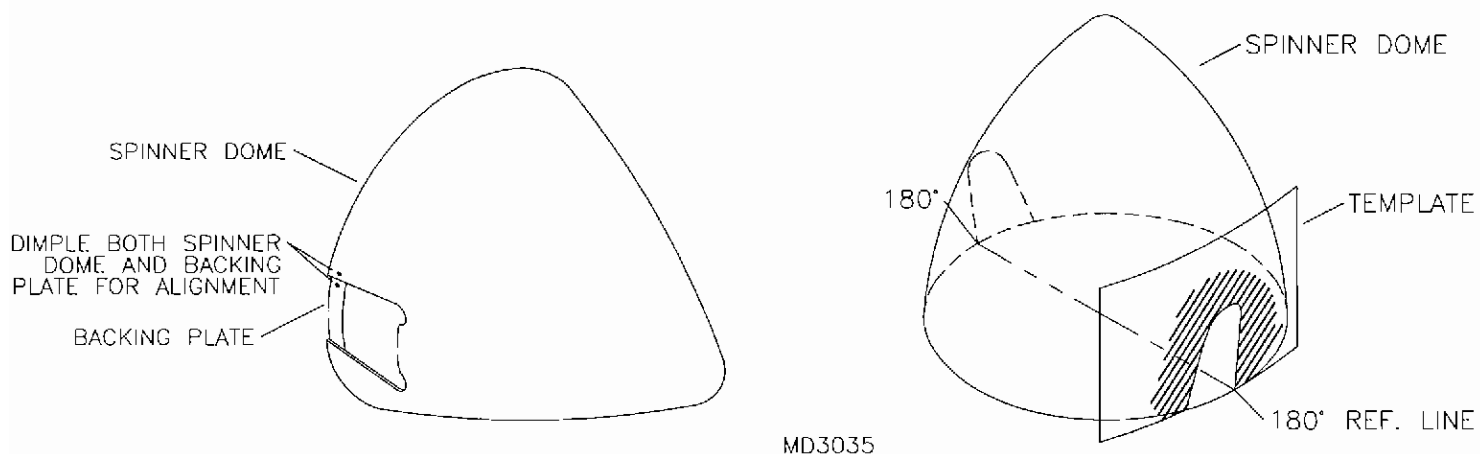
2. Hold the cuff in position. By moving the cuff around a bit you will find where it fits the best. **HINT:** Place tape across the windshield, aft of the cuff, as a straight reference line to make positioning the cuffs parallel to each other easier. Drill through at your marks with a #40 bit and cleco as you go starting near the bottom. Push firmly on the cuff to form it against the wing as you work your way to the top. See **FIGURE 025Pb-01** for starting hole location. Size drill all #40 holes to #30.
3. After drilling and clecoing the cuff in place drill a #30 hole at the top and bottom locations for #8 pan head screws. Before drilling make sure the cuff is tight against the wing by pushing it firmly into the wing. Drill into the root rib on the top and bottom. The screws will self tap into the spar but not without an effort. **NOTE:** The bottom hole will also be used to secure the Wings's Root Gap Seal. Be careful not to slip off the screw and punch a hole in the wing. Remove the screws and clecos and drill the 3/4" for the wing pin in the cuff. **HINT:** A Uni-bit works well. Clean up the 3/4" hole by rolling a piece of 80 grit sanding paper into a cylinder. Sand the inside of the hole smooth. Paint as desired.
4. Drill the #30 holes, in the Lexan only, to #28. Clean the windshield, cuff, and wing of any debris. Cleco the cuff in place. Install the rivets and screws. Make sure you use the small brass washers to back up the rivets. Use extra care in placing the washers; make sure they are up against the Lexan before pulling the rivet. Apply a small fillet of clear silicon seal to the edge of the cuff and windshield junction. A properly installed wing cuff will contour exactly with the wing and windshield as well as provide a water tight joint against the rain.

## SPINNER ASSEMBLY

**NOTE:** To properly fit the cowling the spinner must first be installed.

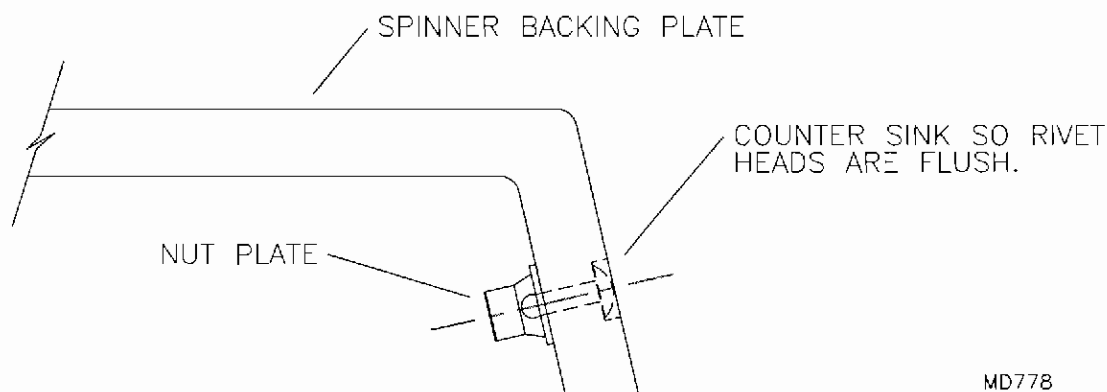
1. Refer to the spinner parts page for selection of components and hardware.
2. The spinner comes ready to trim and drill. The backing plate comes pre-drilled. Observe any scribe lines and trim to these lines. Be especially careful to trim and sand the edges evenly. Check for trueness by setting on a flat surface. The center hole may need a little sanding to fit over the prop flange. Test fit as you go. Wet sand with 350 grit sand paper.
3. Set the prop and backing plate on a flat surface. **NOTE:** To assure accuracy bolt the backing plate to the prop with (3) bolts. (AN4-32A will work if washers are used.)
4. Cut out the spinner to match the prop type. Place the template exactly 180° apart for 2-blades (120° for 3-blades). See **FIGURE 025Pc-04**. Test fit the openings and file to an exact fit. Once the dome is fitted, mark the hole locations on the spinner's perimeter with (5) screws evenly spaced on each side (3 between cut-outs for 3-blades). Drill through at these locations with a #30 bit, cleco as you go. Be sure the spinner and backing plate are flat against the table.

**FIGURE 025Pc-04**



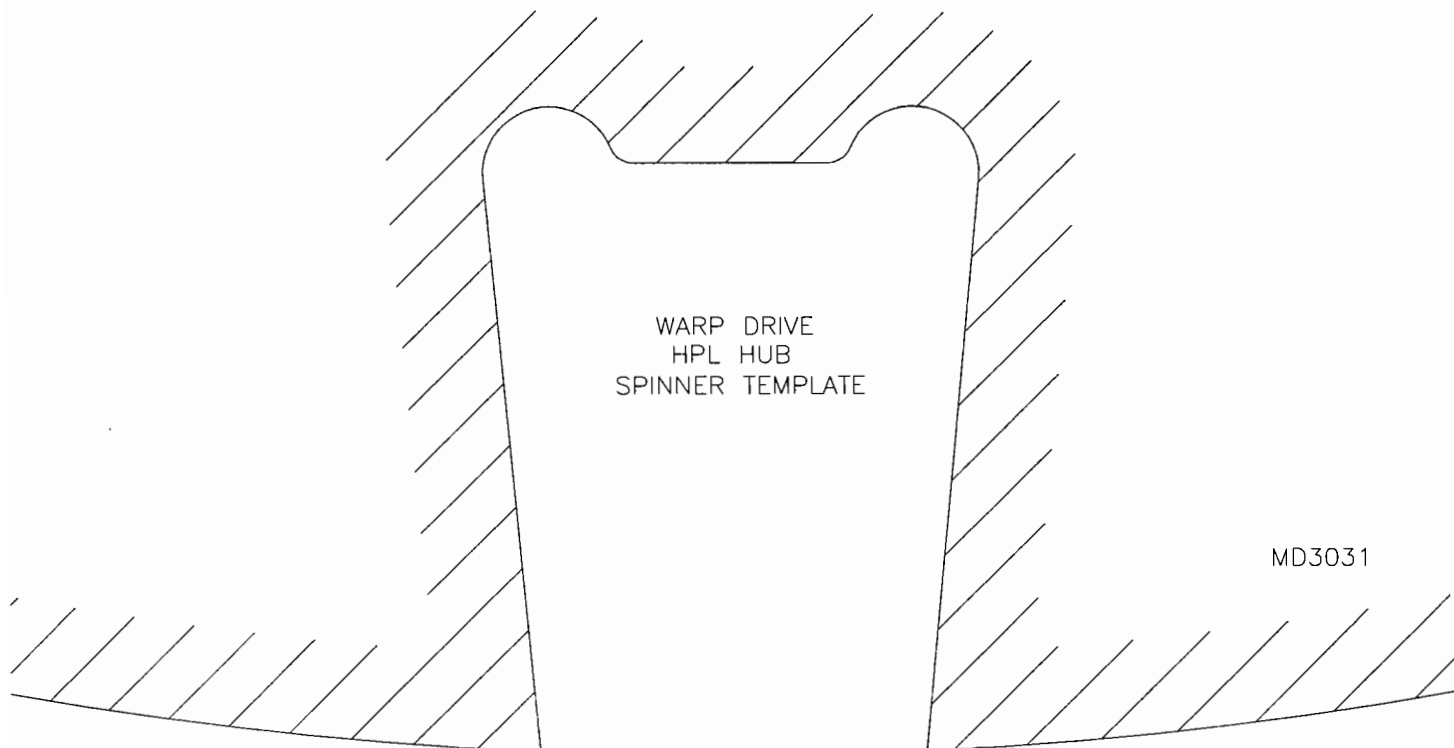
5. Disassemble and drill out the #30 holes to #11. Install the nut plates using a bolt to hold the nut plate in place and drilling from the inside. The rivet heads need to be "counter sunk", do so by drilling a slight depression with a #11 bit. See **FIGURE 025Pc-05**.

**FIGURE 025Pc-05**

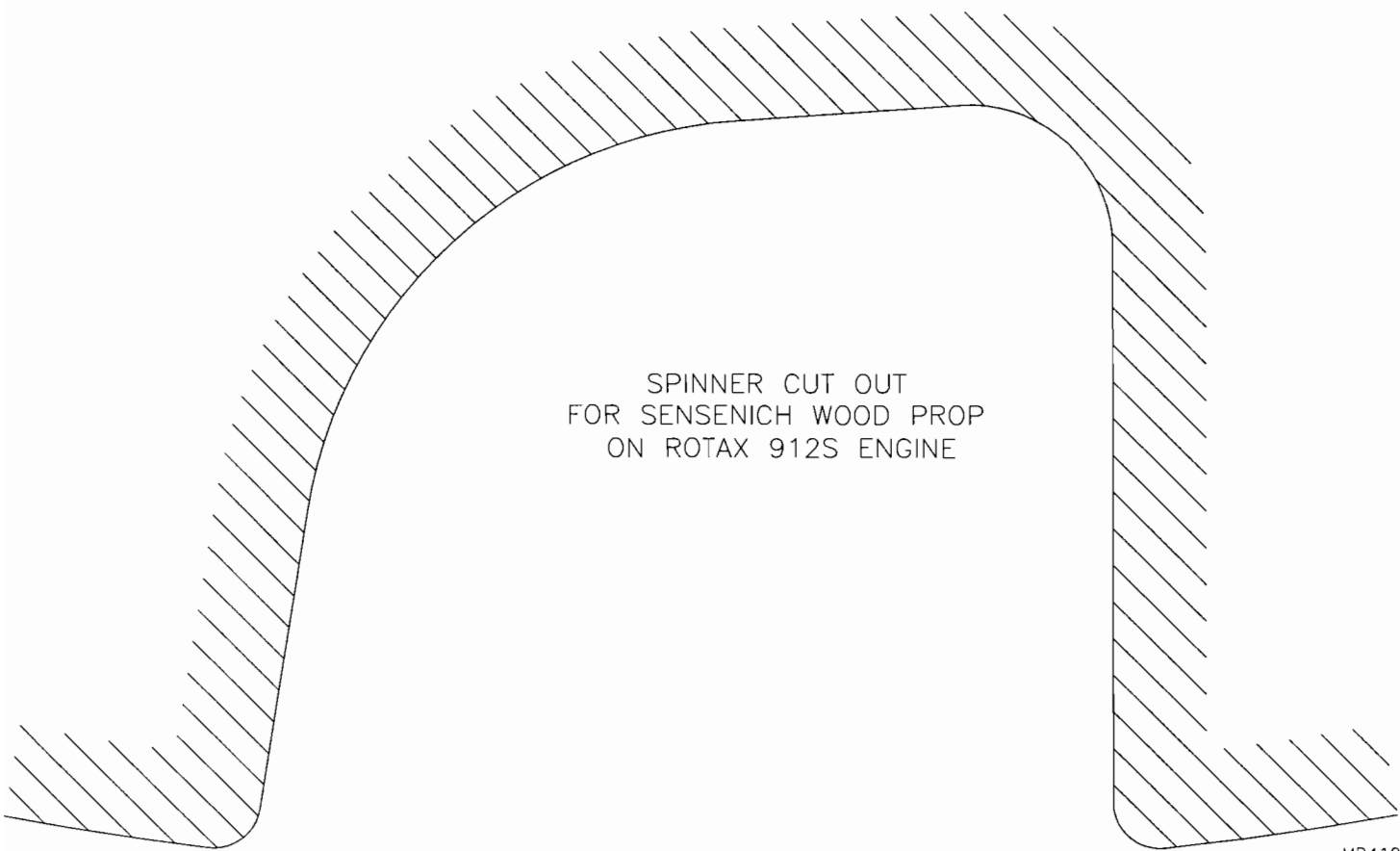


6. Sand the spinner with 350 wet/dry paper. Paint to match aircraft.
7. Bolt the backing plate and spinner to the engine. **NOTE:** *The slight dip in the plate is used to "pre-load" the plate against the prop.* The spinner is used to line up the cowling. The spinner and prop should be balanced and no adjustment required. However, the ultimate test is in the running. If you have a lot of vibration it could be caused by out of balance or misalignment. Use a good prop balancer. Check both the prop and backing plate, if the misalignment is not correctable then a new spinner may be required. Misalignment occurs through improper trimming of the parts. A slight amount of "wobble" is acceptable and may disappear at higher RPM's. Always pre-flight your spinner.

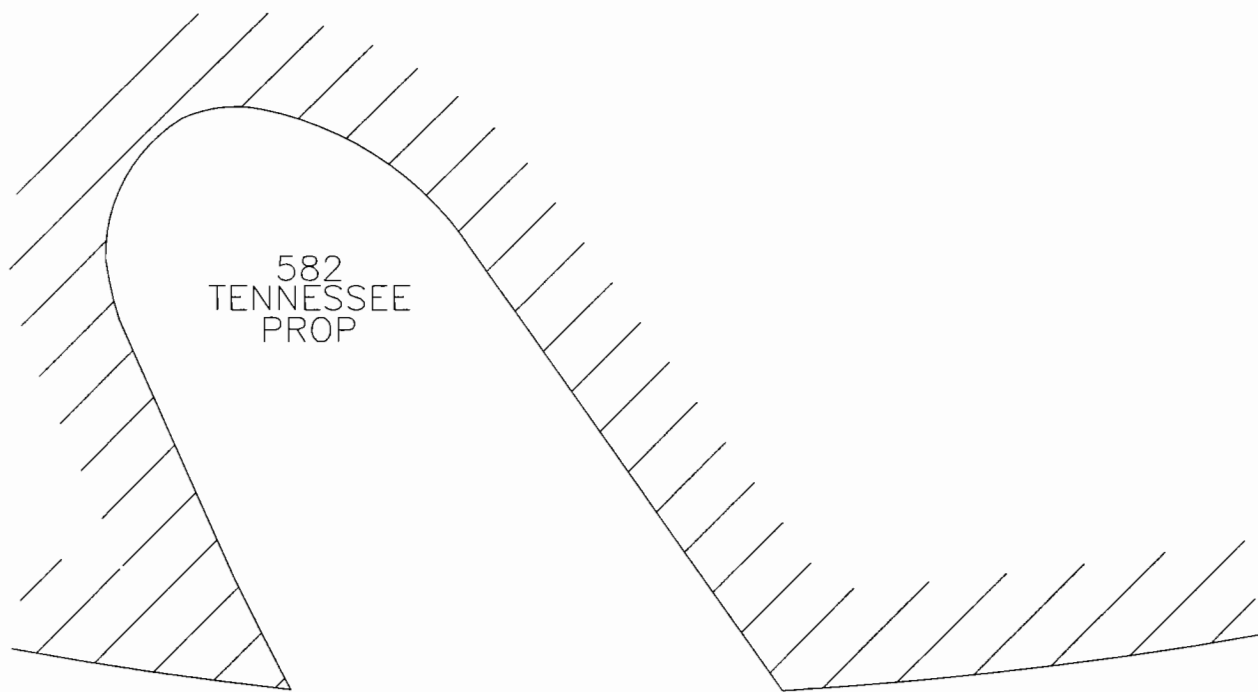
### SPINNER TEMPLATES



SPINNER TEMPLATES



MD4107

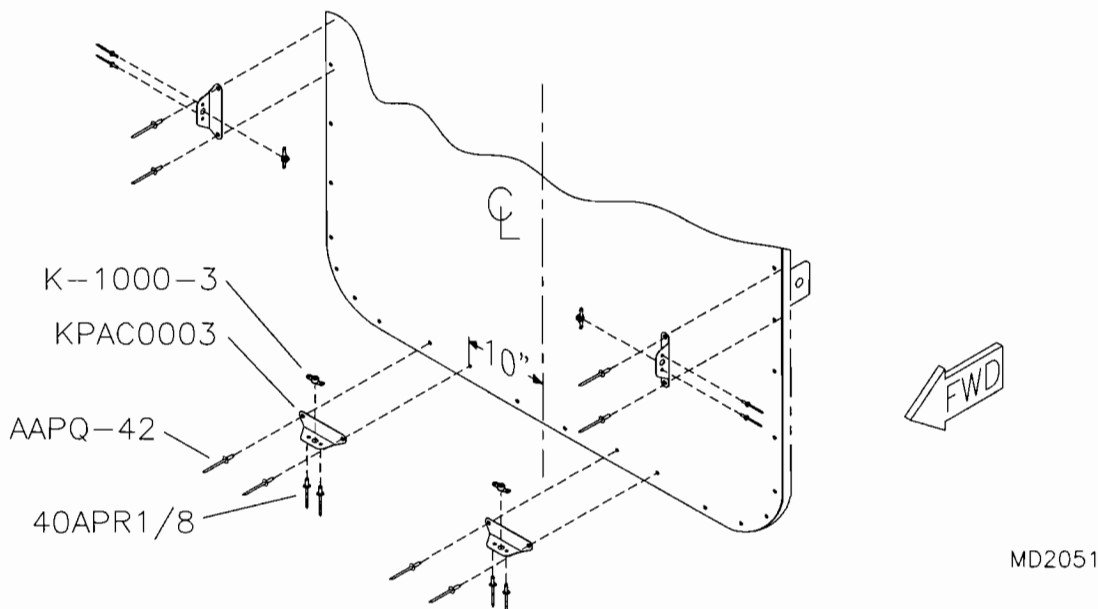


MD3022

## COWLING ASSEMBLY

- Rivet the four cowling attach angles to the firewall as per **FIGURE 025Pd-01**. The attach angles on the side of the firewall locate directly forward of the tabs welded to the aft side of S-1.

**FIGURE 025Pd-01**

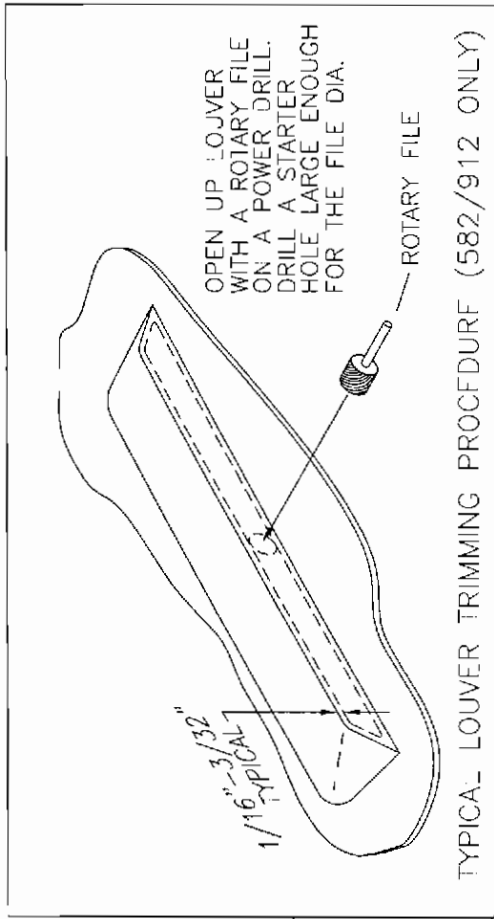


- Bolt the spacer, backing plate and spinner to engine. The spinner is used to line up the cowling. The spinner and prop should be balanced and no adjustment required. However, the ultimate test is in the running. If you have a lot of vibration it could be caused by out of balance or misalignment. Use a good prop balancer. Check both the prop and backing plate, if the misalignment is not correctable then a new spinner may be required. Misalignment occurs through improper trimming of the parts. A slight amount of "wobble" is acceptable and may disappear at higher RPM's. Always pre-flight your spinner.
- Trim the bottom and top cowlings on all edges except the firewall edge and the joint line where the top cowl lies over the bottom cowl. **NOTE:** Trim the top cowl after the bottom cowl has been fit to the firewall. Use tin snips and trim up with a sanding block and 80 grit paper. Finish the edges to the scribed lines. Finish sanding with water and 320 wet dry paper. Open up the cooling louvers using a rotary file in a power drill. See **FIGURE 025Pd-03**.

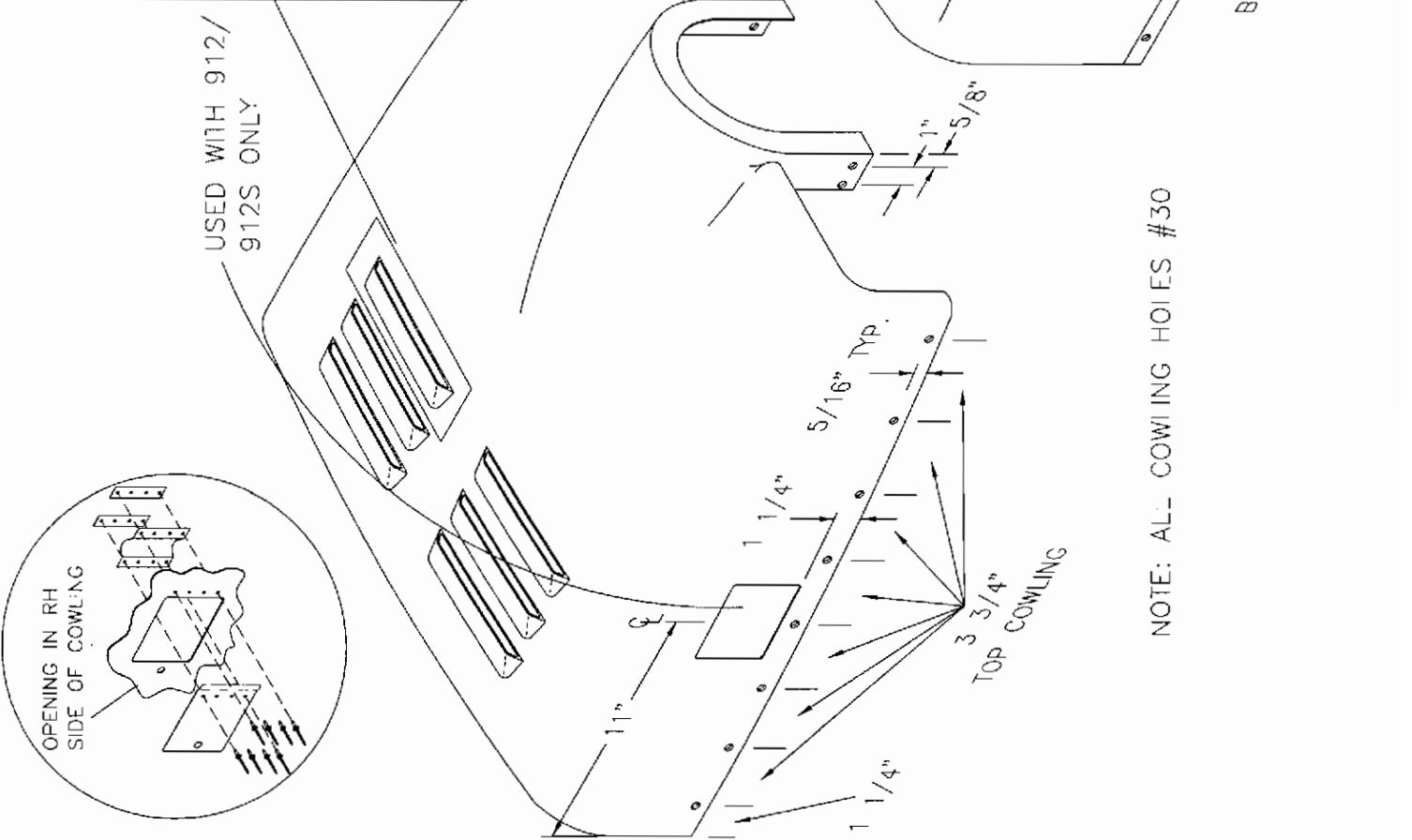
**FOR 912 or 912S ONLY:** After top and bottom halves of cowl have been fitted together and quarter turn fasteners receptacles installed. Mark a hole in the top portion of cowl on the right side. Centerline at hole is 11" from aft side of cowl and 1 1/4" from bottom edge of cowl. The dimensions of the hole are 5" long and 4" tall. Leave 1/4" round corners in hole. Install oil door with fastener hole towards aft edge of cowl. Center door vertically in hole and mark fastener hole on cowl. Install receptacle in same method as cowl half receptacles. See **FIGURE 025Pd-03**. Install vinyl hinge on fwd end of oil door and cowling. Use .020 aluminum strip to sandwich vinyl. Cut .020 x 3/4", 3 1/2" long, drill (Qty 4) #30 holes on centerline of each piece. See **FIGURE 025Pd-03**. Locate holes in cowl 13/16" fwd of cut out. Locate holes in door 1/2" aft of fwd edge of cut out. Sandwich vinyl fabric between strips, cowl and door, excess material will bulge out at fwd edge of cut out to allow door movement, install rivets.



FIGURE 025Pd-03



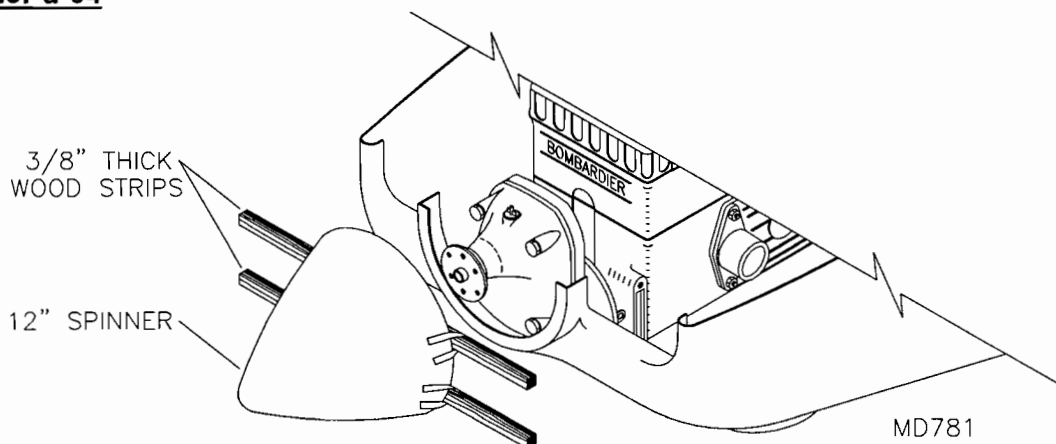
TRIM COWLING UP TO 1" HEIGHT. ROUND AFT EDGE.



MD782

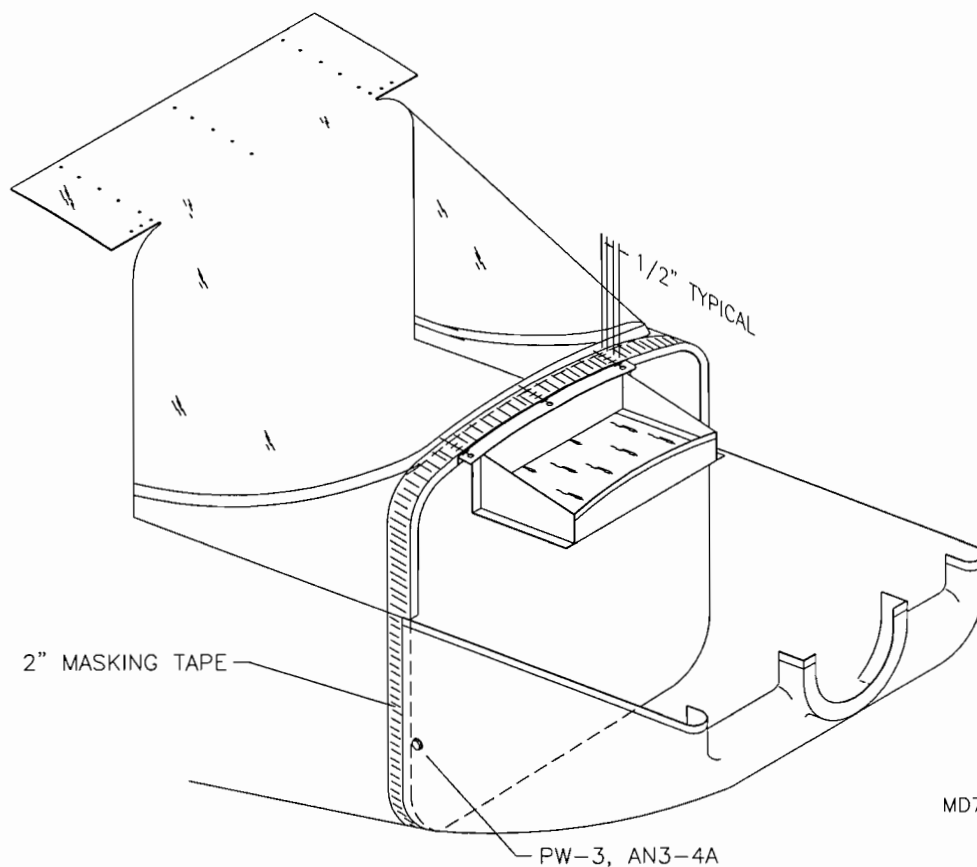
4. Tape a 3/8" strip of wood to the spinner/backing plate assembly. This will establish the gap between cowl and spinner. See **FIGURE 025Pd-04**.

**FIGURE 025Pd-04**



5. Tape all around the firewall with 2" masking tape to protect the edges of the windshield deck and the fuselage skin. Clamp or tape the lower cowl in place. It should touch the 3/8" spacer taped to the spinner. The cowl should fit tight around the firewall and line-up with the spinner. Take an 1/8" diameter drill bit and insert it into each of the lower cowl attach tabs. Spin and press it against the cowl to mark the tab locations. Be sure the cowl is properly positioned. Remove and drill out to #11. Bolt lower cowl in place.
6. Mark a straight line off the center of each of the 3 flange holes. Mark off 1/2" increments on these lines. See **FIGURE 025Pd-06**. These will serve as hole finders, since you now know the center of each hole lies at the end of the line and you know how long the line is.

**FIGURE 025Pd-06**

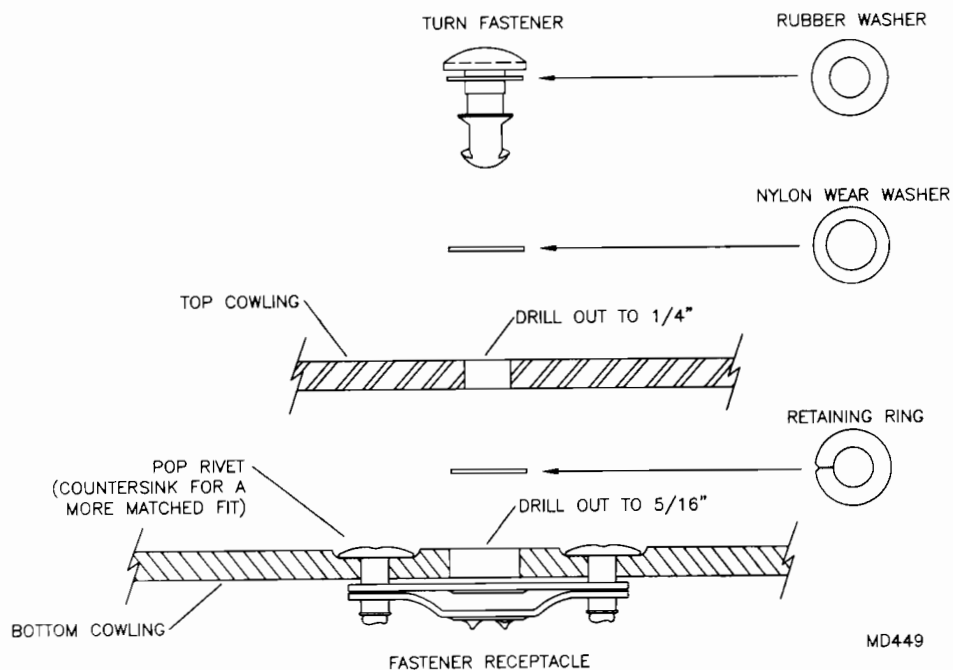


7. Place the top cowling on the aircraft. It should fit tight over the firewall with the edge against the lower cowlings joggle ledge. Trim as required to gain best fit.
8. Locate and drill the 1/4 turn fastener holes in the top cowling. Refer back to **FIGURE 025Pd-03**.
9. Once fitted, tape the cowling halves together and drill through the #30 holes for the 1/4 turn fasteners. Cleco as you go.
10. Using the lines drawn on the masking tape in step 7, locate and drill the aft top 3 holes to #30. Cleco and re-check cowling alignment.
11. If the cowling is not perfectly positioned it is ok to "move" some holes. In fact, vertical slots on the lower cowl sides will usually clear up any alignment problems. Also, since the 1/4 turn fasteners ultimately are drilled out much larger than #30, you can drift hole positions to gain a perfect fit. The perfect fit has the cowling tight on the firewall and lined up on the spinner with a 3/8" gap between. Trim the aft end of the cowling for 1/2" overlap on the fuselage and windshield deck.
12. Remove the cowling and install the 1/4 turn fasteners as follows; the two longer ones go to the forward most outside positions. Do not use the retainer ring on these. When removing the cowling it will be easier if the fasteners are completely removed. Place the retainer rings **AFTER PAINTING**.

### 1/4 TURN INSTRUCTIONS

13. Drill the #30 holes to #11. Cleco a 1/4 turn receptacle into the lower cowling holes and use as a drill guide for the 3/32" rivets. Transfer drill #40. **NOTE:** Do not rivet at this time.
14. Drill out the middle hole to 5/16" and rivet the receptacles to the inside. **NOTE:** For a more matched fit countersink the rivet heads.
15. Drill the holes in the top cowling out to 1/4" and install 1/4 turns as per **FIGURE 025Pd-15**. Do not place retainer clips on forward most outer fasteners.

**FIGURE 025Pd-15**



**S-6ES COYOTE II**

**This section intentionally left blank.**

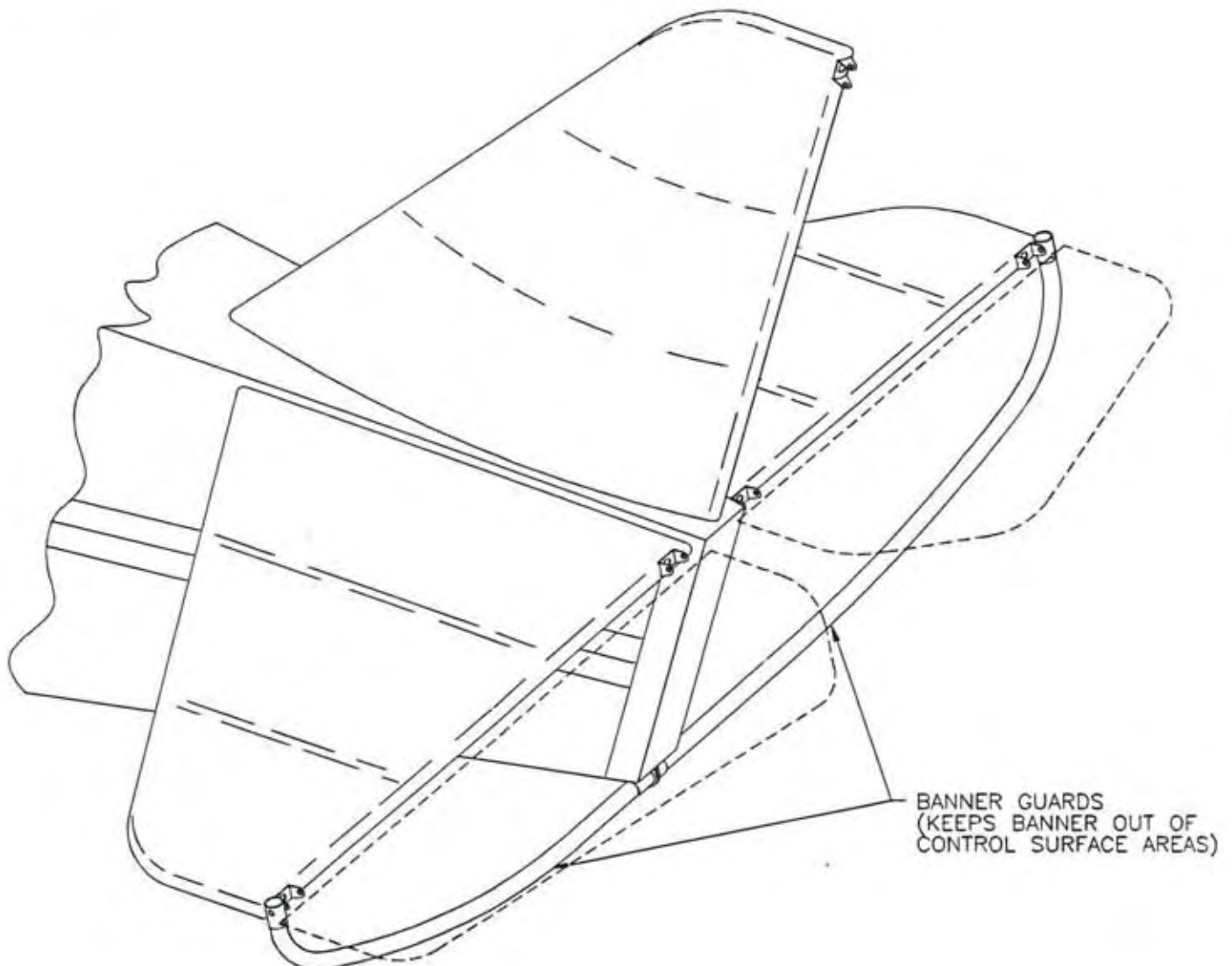
**S-6ES COYOTE II**

**This section intentionally left blank.**

## OPTIONAL BANNER TOW GUARD

1. Snap end caps into outer connect tubes. Caps insert into the end with 3/8" E.D. (the other end has the 1/2" E.D.). Drill #30 hole out to #11 through end cap.
2. Bolt the outer connect tubes to the outboard hinge assembly as per the parts drawing. Fabricate the spacer bushing from the raw stock provided. Bushing should be cut to 25/32" (slightly over 3/4").
3. Slide middle connect tube into the tail tie down hook under tailcone. Use masking tape to hold the connect tube in the center.
4. Place a mark 1 1/2" from the lower end of the banner guard tube. Slide tube into middle connect tube and attempt to align into outer connect tube. A slight amount may need to be trimmed off for perfect alignment. Repeat for other side. See **Figure 025S-04** for orientation of the tow guard.
5. Once happy with fit, drill #30 holes out to #11. Remove, debur, and pin back together with correct hardware. Banner tow guard can be easily removed when not in use using the clevis pins and loc rings.

**FIGURE 025S-04**



## S-6ES OPTIONAL MAP BOX INSTALLATION

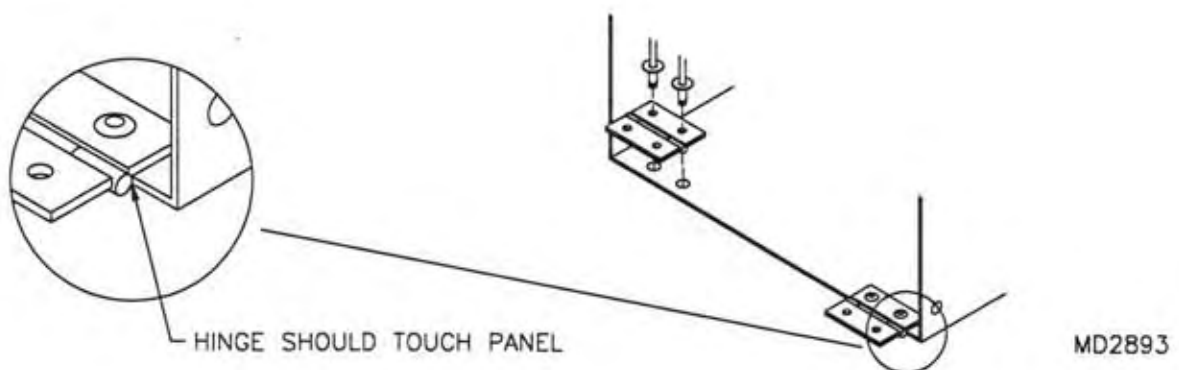
1. The parts to the map box come ready to install. The map box door has been powder coated black and should match with any panel color. However, if you decide to paint the map box door another color, prepare the surface by scuffing with a Scotch Bright pad. No primer is required.
2. The door knob provided is extra long on the threaded shaft. Cut off and file leaving  $\frac{1}{2}$ " remaining. Drill out the knob hole as indicated by the parts drawing to #11 and install the knob.
3. Rivet on the door catch above the door knob as indicated by the parts drawing.
4. Rivet the top panel to the map box. Attach the rollers to the top panel with the small screws provided. The exact location of the rollers will be determined once the door is installed.
5. Fit the front end close out to the narrow end of the box with a non-90 degree bend flange to the top and rivet.
6. If your panel was cut custom for the map box, check the fit of the map box into the panel by clecoing it to the front side of the panel. Remember the front side of the panel is not the side the pilot sits on! Rivet from the pilot side after fit-up checks out.

For the non-custom panels, place the map box in position over the hole in the panel. Check if the opening is large enough to file to suit. With the box in the proper location, drill and cleco. **HINT:** Use an extra long #30 drill bit to gain the best access to transfer drill through the attach angles.

7. Place a center mark on the top front edge of the map box. Place another mark  $\frac{1}{4}$ " to each side of the center mark. Place the front attach angles to the front of the map box so they are centered on the  $\frac{1}{2}$ " tube and flat against the map box. Each inside edge of the angles should line up with their respective mark at  $\frac{1}{4}$ " off center line. Use masking tape to hold the angles in place. Drill and rivet the angles to the map box front. Drill into the  $\frac{1}{2}$ " tube on center line and rivet with stainless steel rivets.

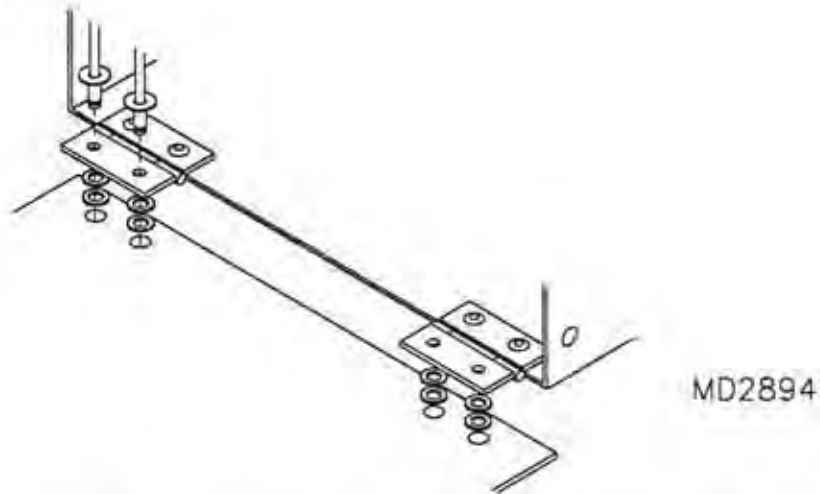
8. Rivet the hinges to the door edge of the map box as shown in **Figure 025T-08**.

**FIGURE 025T-08**



9. Rivet the door to the hinges placing a double stack of washers between the hinge and door as shown in **Figure 025T-09**.

FIGURE 025T-09



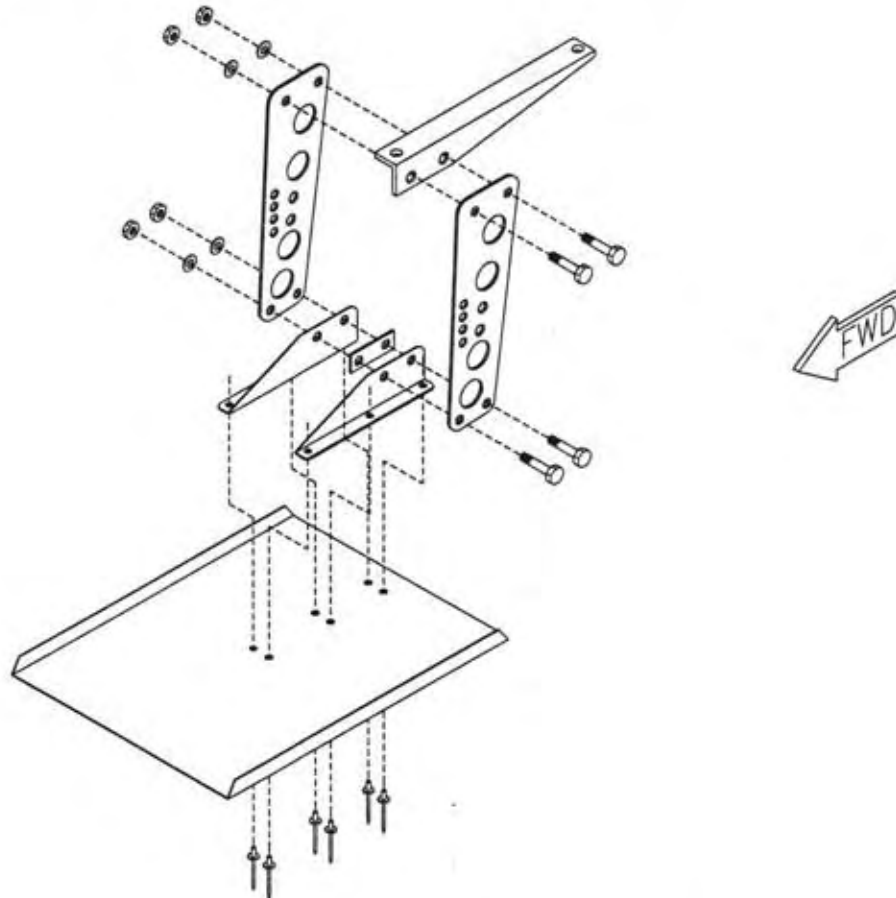
10. Test operate the door. It should be held firmly closed by the clasp. If the door does not close properly, adjust the roller location. Trim off the screws once the door catch is properly set.
11. In some cases, a magnetic compass maybe installed on the top of the dash. Placement of metal objects in the map box may cause the compass to be unreliable. Please post the warning decal provided.



## OPTIONAL AILERON SPADE ASSEMBLY & INSTALLATION

1. Assemble the aileron spade assembly as per **FIGURE 025U-01**. Attach the spade assembly to the aileron using the hardware called out in the parts drawing. The spade is designed to allow a  $\pm 3^\circ$  angle adjustment. The spade will be adjusted during initial flight tests. Extra holes for the push tube attach allow various feels. Use lower holes for light feel, slower roll.

**FIGURE 025U-01**



MD742

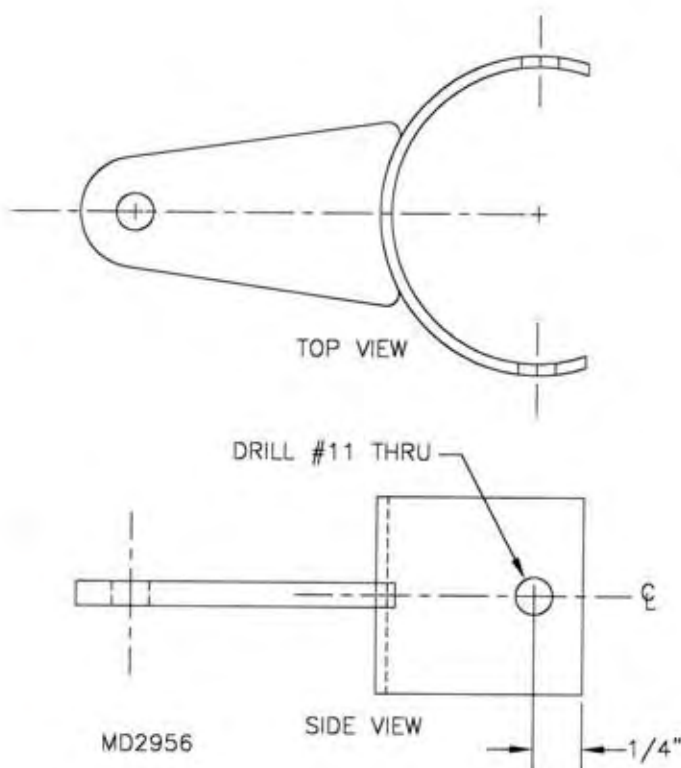
Thread the male rod end and jam nut onto the end of the push pull tube. Attach the push pull tube to the aileron control horn. Remember to install the 2 plastic washers between the control horns. **HINT:** tape the washers to a piece of masking tape to allow easy insertion between the horns.

## S-6ES TRIKE OPTIONAL NOSE GEAR SHIMMY DAMPENER

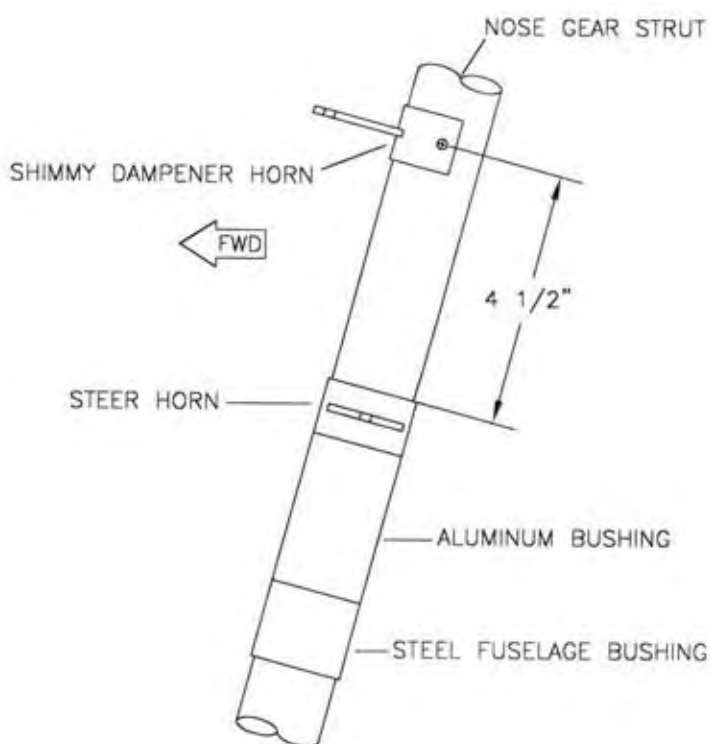
**NOTE:** It is important to maintain tight hole tolerances in the installation of the shimmy dampener. The effectiveness of the dampener will be compromised if any play exists within the system. The nose gear must be completely installed prior to installing the shimmy dampener. Refer to the nose gear installation section.

1. Locate and drill the #11 attach holes in the dampener horn as shown in **FIGURE 025-01**. Position the horn on the nose gear strut 4 1/2" up from the top edge of the nose gear steer horn to the tab on the shimmy dampener horn with the tab pointing forward. See **FIGURE 025-01A**. Holding the horn parallel to the centerline of the fuselage, transfer drill through the attach holes in the horn into the nose gear strut. Bolt the horn to the strut.

**FIGURE 025-01**



**FIGURE 025-01A**



2. Install the jam nut and clevis onto the piston of the shimmy dampener. Thread the clevis on as far as possible and tighten the jam nut. Refer to the parts drawing. Attach dampener to the horn tab. The dampener should extend to the left of the strut.

3. Drill out both holes in the shimmy dampener mount to #11. Temporarily attach the mount to the dampener. With the dampener level, extend the dampener to the point that the slot in the mount will fit around the left hand diagonal brace tube in station 1. With the dampener and mount in position, mark the outboard hole location of the mount onto the firewall. Remove the mount from the dampener and using the mount as a guide, mark the inboard hole location on the firewall. Drill both holes in the firewall to #11.

4. Drill out both holes in the shimmy dampener backing plate to #11 and pre drill the nut plate holes. Do not rivet the nut plates to the backing plate at this time. Position the backing plate on the forward side of the firewall so that the holes in the backing plate line up with the holes in the firewall. Temporarily install two bolts into the holes to maintain alignment. Using a #40 bit and the nut plate mount holes as a guide, transfer drill through the backing plate into the firewall. Rivet the nut plates to the forward side of the backing plate/ firewall. Note the direction of the rivets used to secure the nut plates. Refer to the parts drawing.
  
5. Bolt the mount to the aft side of the firewall. Bolt the shimmy dampener to the mount with the plastic washers between the mount and the dampener.

**S-6ES COYOTE II**

**This section intentionally left blank.**

**S-6ES COYOTE II**

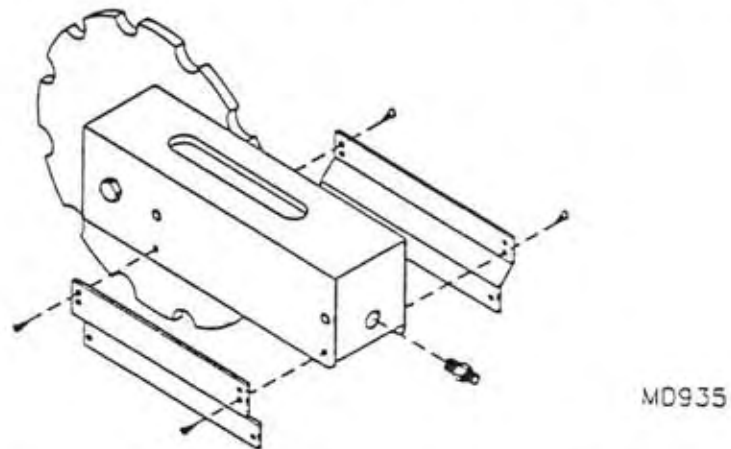
**This section intentionally left blank.**

## S-6ES OPTIONAL TRIM SYSTEM INSTALLATION

**NOTE:** Trim system cable/housing should be zip-tied within fuselage prior to covering.

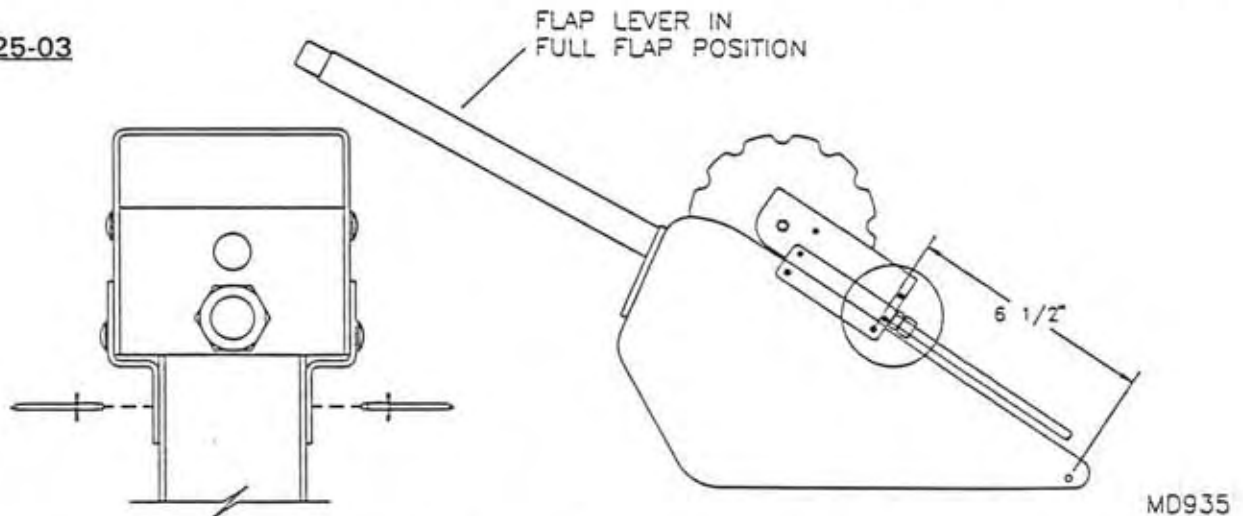
1. Screw fitting into aft (bottom, for panel-mounted option) end of trim wheel assembly, per **Figure 025-01**. If mounting to panel, skip to step 4.
2. Attach trim assembly mount brackets to trim wheel assembly, using its 4 x 1/4" screws, per **Figure 025-01**.

**FIGURE 025-01**

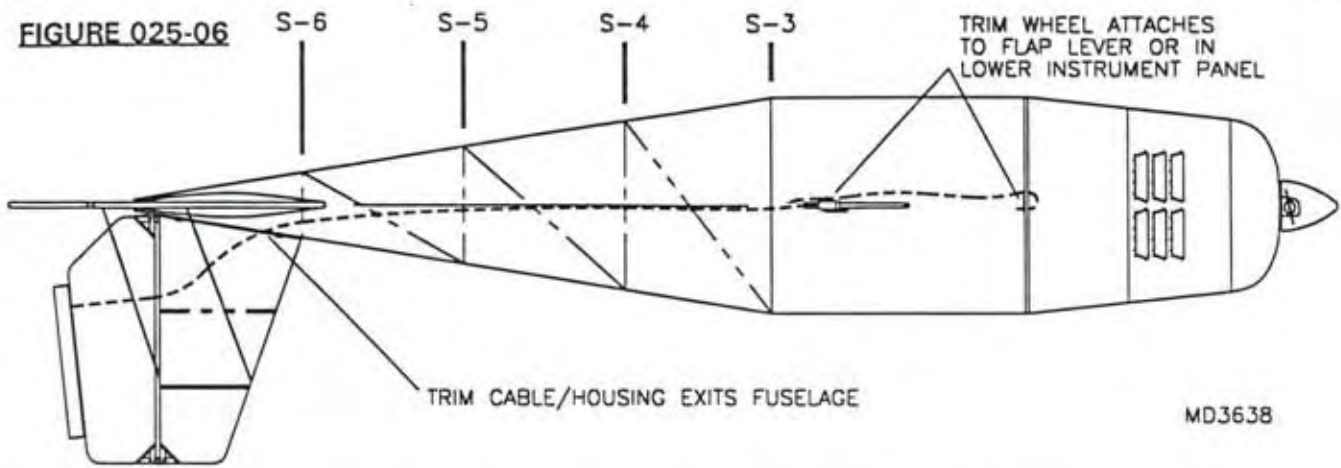


3. Locate trim wheel assembly on flap lever mount, per **Figure 025-03**. Pull lever to "full flap" position and check for clearance. Drill flap mount and rivet trim wheel assembly in position. Skip to step 5.

**FIGURE 025-03**



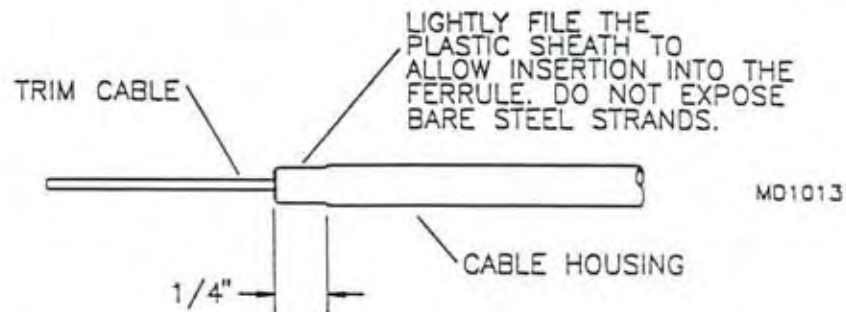
4. For panel-mounted option, locate trim wheel assembly to forward side of panel, matching wheel and indicator to respective slots. Rivet assembly in position. See parts drawing.
5. Cut cable housing to approximate length, leaving generous margin for error; housing will be cut to final length after installation. Straighten approximately three feet of cable and bevel its end smooth. Pull housing straight and carefully feed straightened cable into housing; leave plenty of cable extending beyond both ends of housing. *If housing is not straight while inserting cable, cable's leading end may damage housing's nylon lining, jamming system.*
6. Install cable/housing to fuselage, routing along right side of interior; secure with zip ties to avoid interference with rudder and elevator controls. Avoid sharp bends that may cause binding; see **Figure 025-06**.



Once fuselage is covered, make a very small hole in skin, immediately below right stabilizer, a few inches aft of leading edge. A fine-tip hot knife will neatly "melt" hole, preventing Dacron threads from fraying; *hole should be no larger than necessary to accommodate cable housing*. Before skin is laced along bottom centerline, reach into fuselage and feed one or two feet of cable/housing out hole. Retract forward end of cable enough to allow trimming forward end of housing; carefully file ends of housing as necessary to remove burrs that may cause wear and eventual failure.

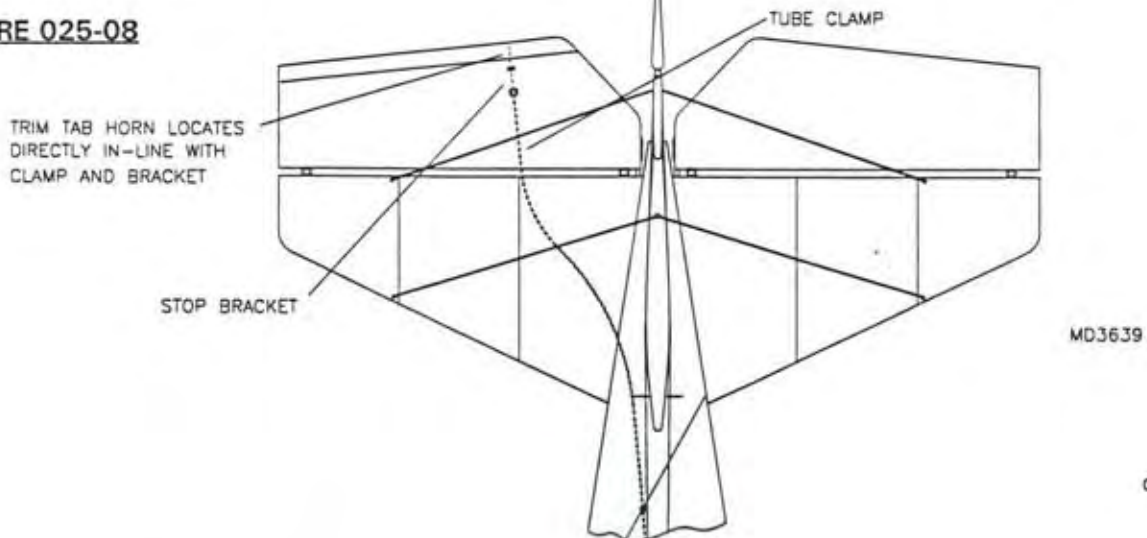
7. Install forward end of housing into fitting on trim wheel assembly; it may be necessary to lightly file plastic sheath to allow proper insertion. *Do not remove plastic sheath to bare steel strands; fitting will not grip strands and failure may result.* Refer to **Figure 025-07**.

**FIGURE 025-07**



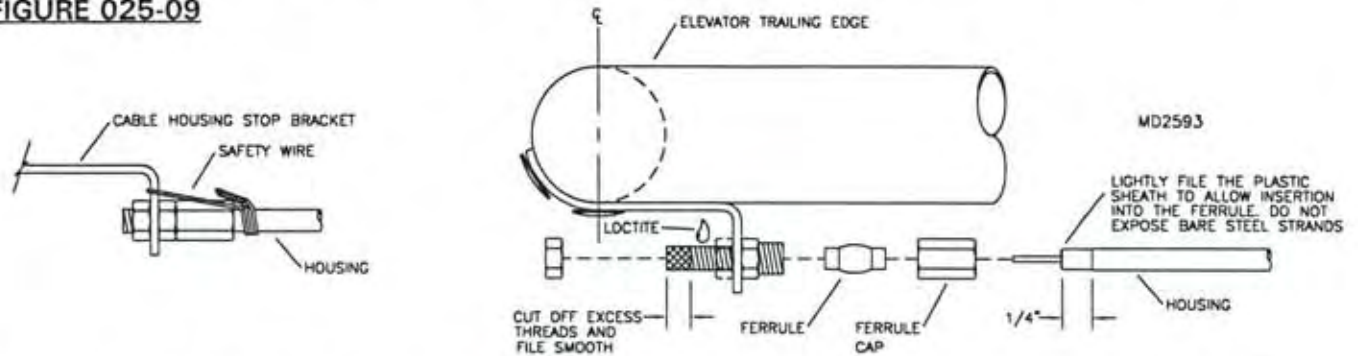
8. Locate and drill 1/4" hole on underside of right elevator leading edge spar; assemble cushioned tube clamp to leading edge, per parts drawing. Locate, drill and rivet cable housing stop bracket to underside of elevator trailing edge spar, per parts drawing. **NOTE:** clamp and bracket must align at right angle to elevator trailing edge; see **Figure 025-08**. Assemble conduit adjuster assembly to stop bracket; trim excess threads, leaving approximately 1/4" of threads exposed beyond nut. Apply Loctite during assembly.

**FIGURE 025-08**



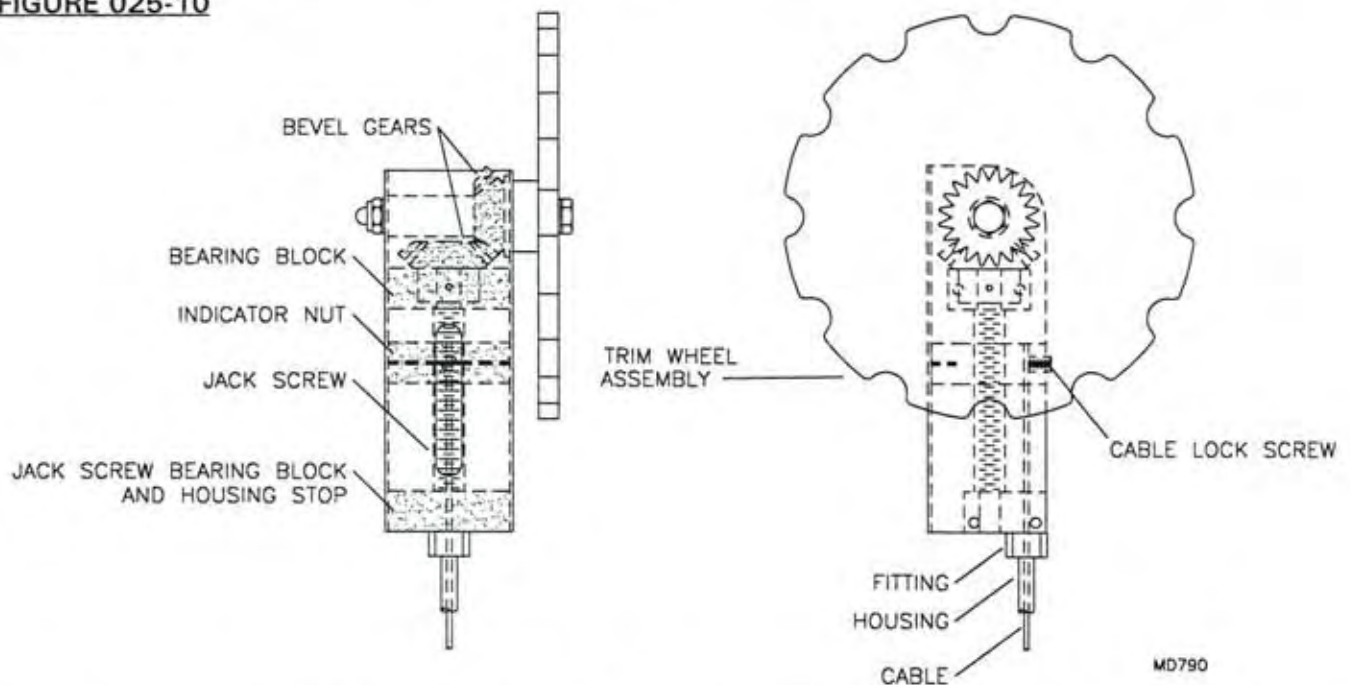
9. Trim housing to final length. Install cable/housing through ferrule cap and ferrule of conduit adjuster; tighten. Safety-wire housing to assembly. See **Figure 025-09**.

**FIGURE 025-09**



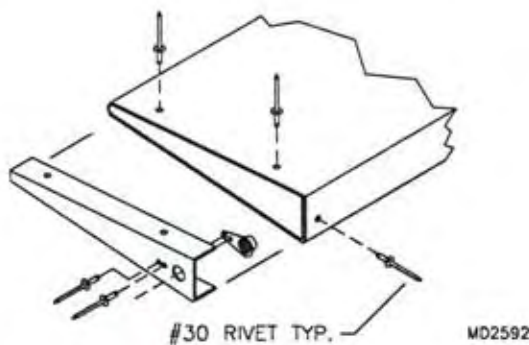
10. Extend cable through and slightly beyond trim wheel indicator nut. Tighten cable lock screw and bend cable end against top of nut. Refer to **Figure 025-10**.

**FIGURE 025-10**



11. Assemble trim tab, per **Figure 025-11**. Be certain tab is not twisted when drilling and riveting.

**FIGURE 025-11**



STEP 1: CLECO LEADING EDGE OF TAB WITH #40 CLECOS. PLACE ON FLAT SURFACE AND CHECK FOR STRAIGHTNESS, DRILL TO #30 (LEADING EDGE ONLY). RIVET WITH AAPQ-41 RIVETS. (BE SURE BOTH LAYERS OF METAL ARE DRAWN TOGETHER PRIOR TO RIVETING).

STEP 2: DRILL AND RIVET NUT PLATE TO EACH END RIB.

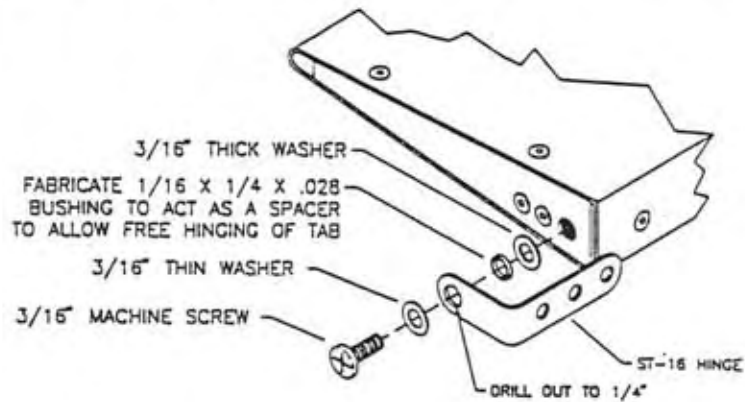
STEP 3: INSERT NUT PLATED END INTO TAB AND RIVET.



12. Attach hinges to tab, per **Figure 025-12**. Center tab on elevator trailing edge. Locate innermost holes of tab hinges on centerline of trailing edge; drill trailing edge to #11 through holes. Remove hinges from tab and rivet to elevator. Drill remaining holes and rivet; install tab to elevator.

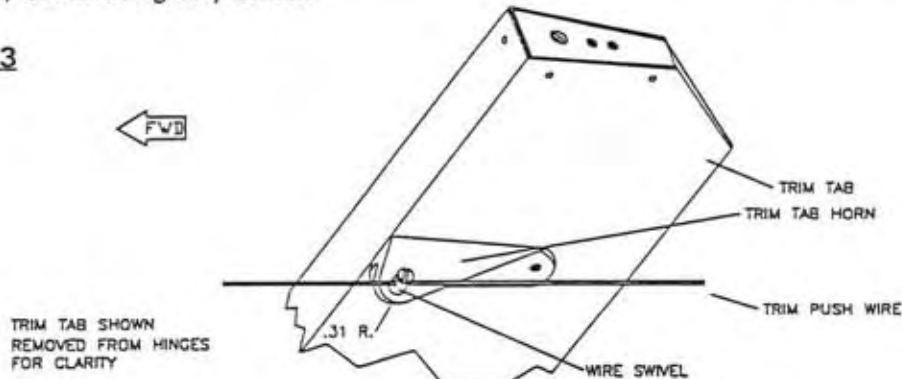
**FIGURE 025-12**

MD 2593



13. Drill hole for tab horn swivel to 1/4". Test fit wire swivel/screw stop; file until it turns freely. Locate and rivet horn on underside of tab, directly in-line with tube clamp and stop bracket on elevator. Refer to **Figure 025-13** and parts drawing. Install wire swivel to horn and thread cable through swivel, eliminating any slack.

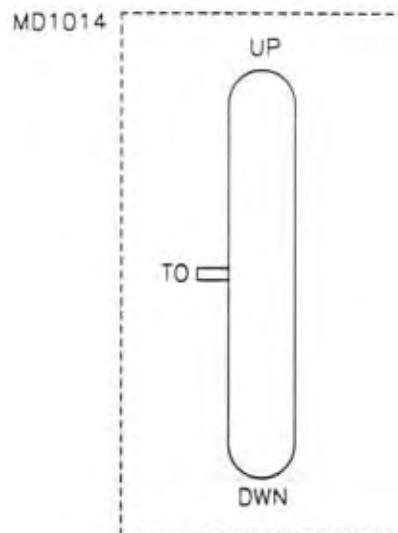
**FIGURE 025-13**



14. Set both indicator nut and tab to neutral positions. Apply Loc-tite to wire swivel set screw and tighten to secure cable. Trim excess cable.

15. Test trim system. Gearing provides fine adjustment; movement of cable and tab should be smooth and free of binding. Mark trim indicator with labels. Trim is normally set neutral for takeoff; this should correspond to middle of indicator. See **Figure 025-15**. Check that tab position corresponds with indicator.

**FIGURE 025-15**

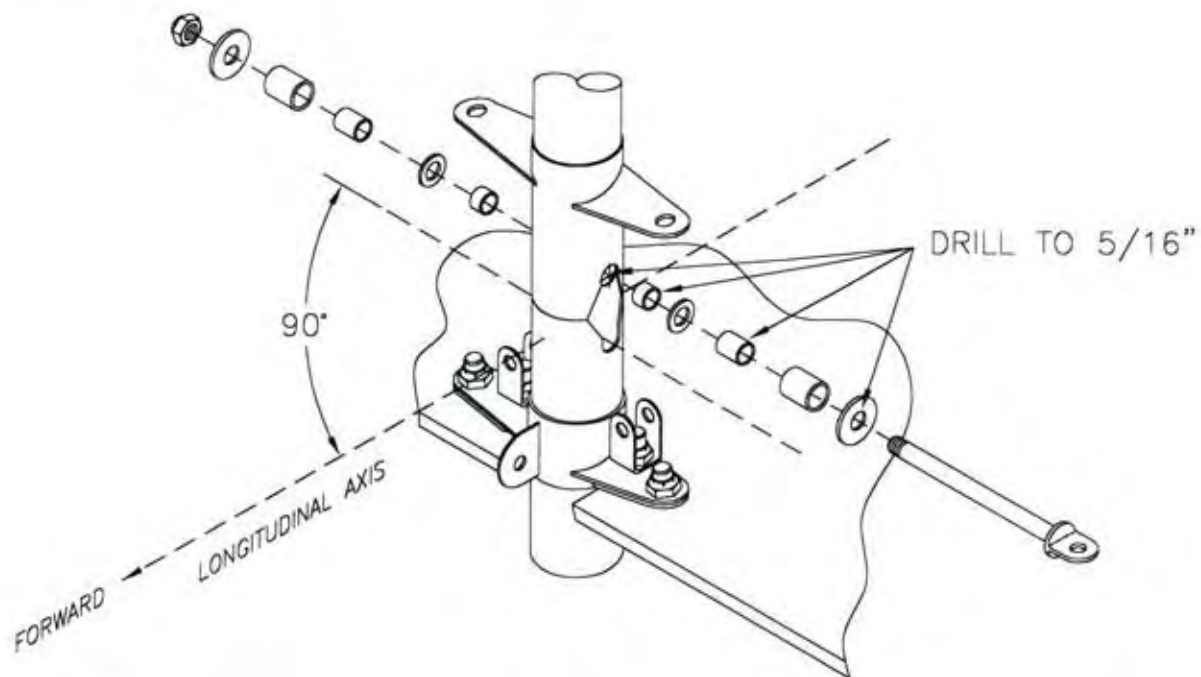


## S-6ES OPTIONAL NOSE GEAR DISCONNECT

**NOTE:** Cabin floorboard must be in place prior to installation of optional nose gear disconnect. Refer to FLOORBOARD & RUDDER PEDAL INSTALLATION section. To assemble nose wheel, fork and strut, refer to NOSE GEAR ASSEMBLY section.

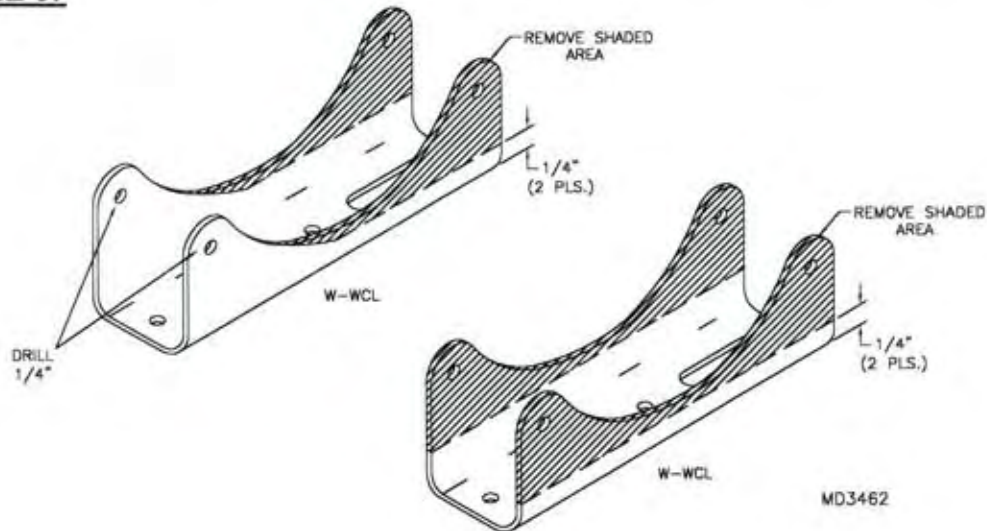
1. Place locking cam over swivel bushing on floorboard; if necessary, remove inside powdercoat or grind locking cam to fit. Make certain locking cam is oriented with attach tangs at right angles to aircraft longitudinal axis and vertical tab forward, as per parts drawing. Locate holes on floorboard through attach tangs. **CAUTION:** Location is critical, as holes will be drilled immediately adjacent to steel tubes under floorboard.
2. Using a #11 bit, transfer drill holes through floorboard, making certain to avoid steel tubes; secure locking cam to floorboard, as per parts drawing. **NOTE:** Steel tubes will be sandwiched between floorboard and lower aluminum shims.
3. Attach keep rod as per parts drawing. Keep rod ensures proper distribution of nose gear loads.
4. Apply grease to nose gear strut. With thrust bearing and washers in place, slide strut through locking cam, steer cam and nose gear sleeve, into top swivel bushing, as per parts drawing. Check for binding; strut should slide and rotate smoothly and easily at all points and be free of play. If binding occurs at locking cam, loosen hardware and adjust alignment. If binding persists, remove strut and grind bushing or cams as necessary; grease as required.
5. Cut 3/8" and 1/2" bushings from raw stock. Drill 3/8" steel bushings to 5/16". With nose gear strut seated against bearing and bearing washers, mark and drill 5/16" holes through both sides of strut, centered on apexes of steering cam cutouts, through which eye bolt will mount. **HINT:** Place the 3/8" steel bushing tight in the steer cam and use as a drill guide to mark the gear strut. Remove gear strut and drill in a drill press to assure a tight fit. See **FIGURE 025Z-05**. **CAUTION:** Location is critical; be certain nose gear is straight (wheel axis perpendicular to aircraft longitudinal axis) when locating holes. During ground operation, steering cam will rest on steel bushing on the eye bolt, transmitting steering inputs from rudder pedals.

**FIGURE 025Z-05**

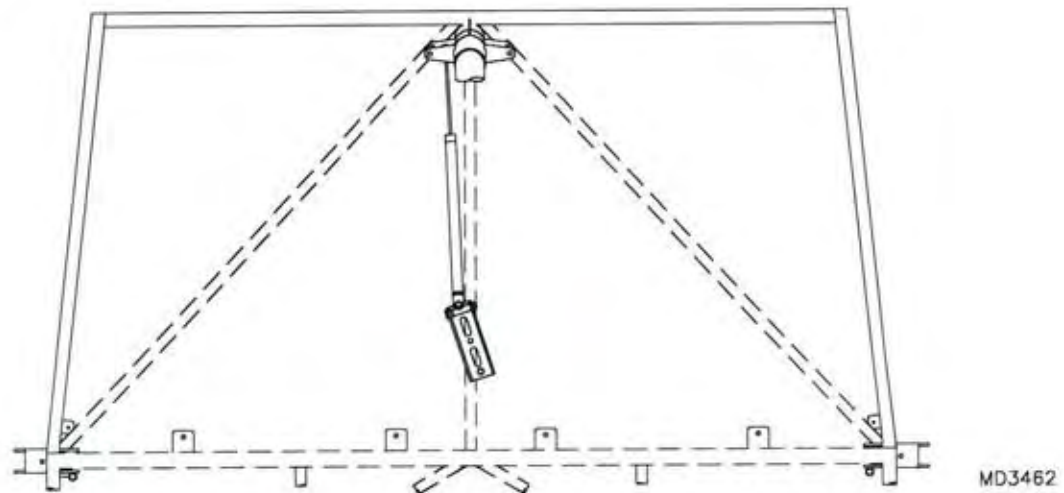


MD3462

6. Drill 1/4" large washers to 5/16". Insert 1/4" aluminum bushing into eyebolt hole and trim to same thickness. Install eyebolt to strut with associated hardware. Springs anchored to locking cams wrap over bushings on eyebolt, ensuring that bushings seat in cutout when airborne. **CAUTION:** Do not over-tighten eyebolt, as the steel bushings must roll to lock into cutouts.
7. Cut sides of one wing channel to 1/4". Cut another channel similarly, but leave one pair of tangs; size drill holes in tangs to 1/4". See **FIGURE 025Z-07**.

**FIGURE 025Z-07**

8. Bolt clevis to eye bolt. Extend dampener rod half way and screw to clevis. Bolt long wing channel and associated hardware to dampener, as per parts drawing. Keeping nose wheel straight, locate channel over cabin centerline. See **FIGURE 025Z-08**. **CAUTION:** Location is critical, as holes will be drilled immediately adjacent to tube beneath floorboard. By extending dampener rod one-half its length and ensuring nose wheel is straight, dampener will allow full rudder travel.

**FIGURE 025Z-08**

9. Transfer drill #11, both end holes in channel, through floorboard. Holes will bracket centerline fuselage tube. Secure channel to floorboard as per parts drawing.

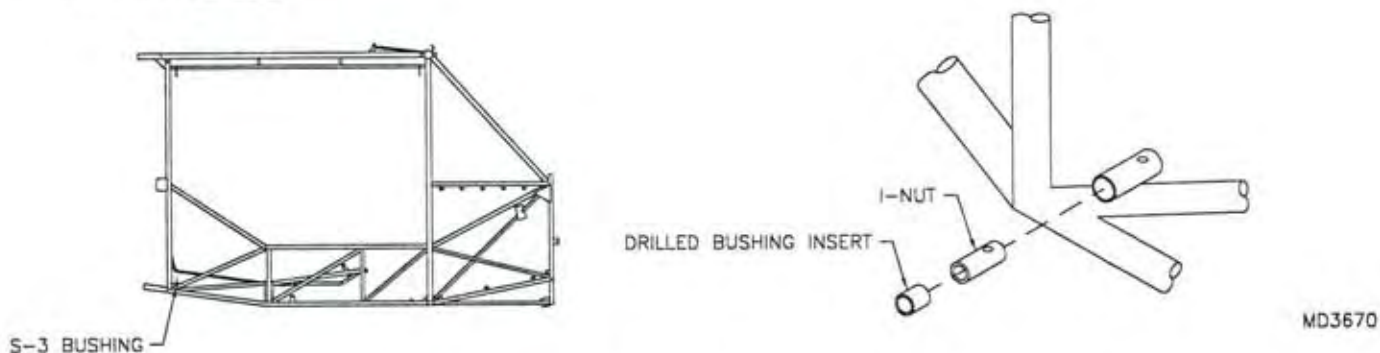
## RANS S-6ES OPTIONAL SWING WING SYSTEM

Review instructions thoroughly before starting; refer to appropriate parts drawing during assembly and installation. To assemble wing supports, wings must be mated to fuselage.

Swing Wing System comprises wing supports, tail braces, associated airframe components and hardware. While stowed, wings rest on wing supports and are secured to the tailcone by braces.

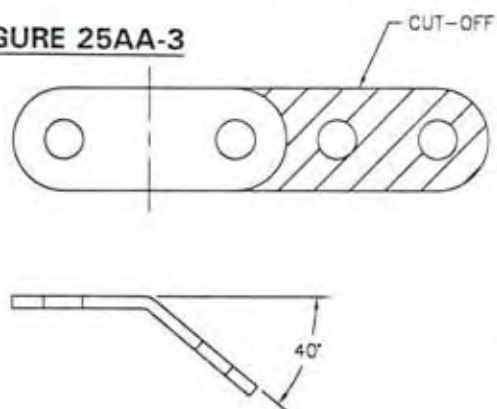
1. Locate hole for nut plate along aft side of leading edge spar, 1 1/16" below center of Clevis pin hole and 1 3/8" from spar's root; drill 1/4". Center nut plate over hole to locate and drill #40 rivet holes; rivet nut plate *inside* spar, per parts drawing.
2. Install I-nut, bushing insert and associated hardware to S-3 bushing, per **Figure 25AA-2**. (Wing support will attach to fuselage at S-3 bushing; I-nut is threaded to accept U-bracket of wing support's lower TE support tube.)

**FIGURE 25AA-2**

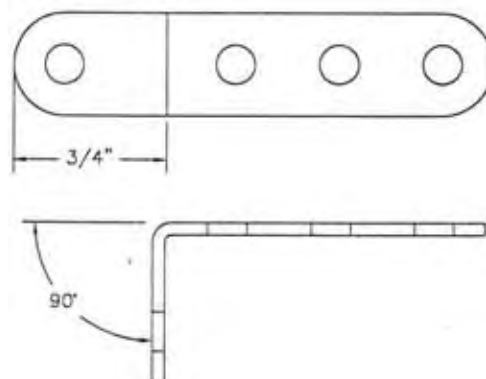


3. Cut and debur four (4) ST-16 tangs per **Figure 25AA-3**. Bend tangs 40 degrees (this may be done by mounting in vise and tapping with hammer). **NOTE: Modified tangs bolt to horizontal and vertical stabilizers. See parts drawing and following instructions. Bend two (2) ST-16 tangs at right angles, per Figure 25AA-3A.** Locate and rivet modified tang at edge of opening in root skin from which aileron push-pull tube emerges. Position tang so tube may be pinned to it. Refer to parts drawing. (Tang may be mounted to either inside or outside of rib skin.) **NOTE: Orientate the hole in the aileron push-pull tube vertically. Be careful not to change the rigged length. The retainer will keep the push-pull tube from rotating when the wings are folded.**

**FIGURE 25AA-3**



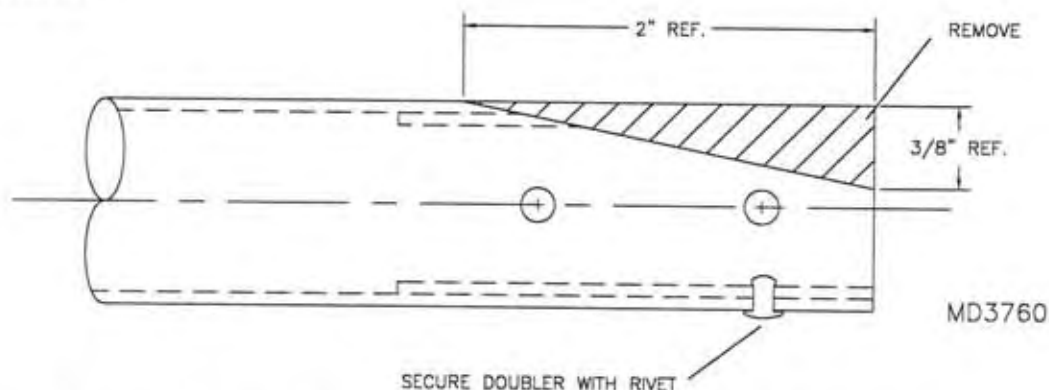
**FIGURE 25AA-3A**



4. Insert eye bolt, washer and shear nut to upper end of aft strut, per parts drawing.
5. Locate skylight support on aft end of wing root, per parts drawing; top surface of support should be flush with top of rib. Transfer locations of rivet holes in rib clip and aft rivet hole in root rib skin to skylight support; drill #30 and rivet skylight support in place. (Skylight will rest on skylight supports when wings are stowed.) Trim the skylight as needed to clear the flap.
6. Install swing wing U-bracket to pivot tube per parts drawing. Size-drill holes near top of lower TE support tube to 1/4". Slide lower TE support tube onto pivot tube until bend impedes travel; transfer-drill four holes near bottom with #11 bit and rivet. *Be certain to transfer-drill so that holes at upper end of lower TE support tube are vertical when fitted to aircraft; see parts drawing.* Slide middle TE support tube onto lower TE support tube, align #40 holes and transfer-drill to 1/4".
7. *For 116 wing:*

Fabricate doubler by cutting three-inch length from lower end of TE doubler/extension. Slide doubler into top of upper TE support tube (top is identified by #40 holes 1/2" from end); secure by drilling #40 about 1/2" from end and riveting. Transfer-drill 1/4" through pre-located holes near top of upper TE support; cut and deburr per **Figure 25AA-7**. Place lift strut connector along upper TE support tube to locate second bolt hole and transfer-drill 1/4". Slide connector into upper TE support, install bushings and secure with hardware per parts drawing.

**FIGURE 25AA-7**



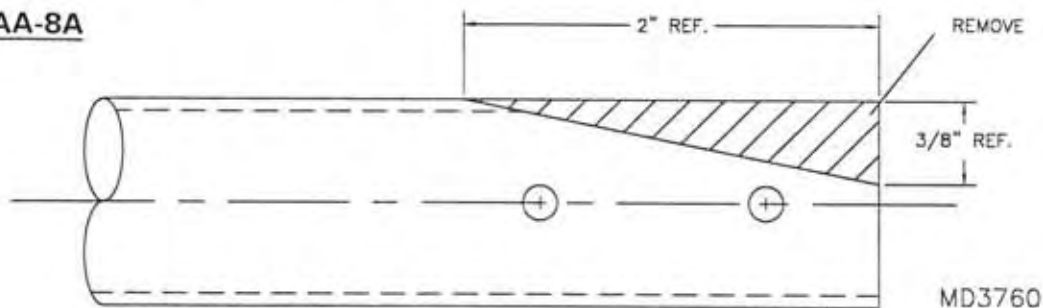
Screw lower TE support tube into fuselage. Pin upper TE support tube to aft strut eyebolt. Slip middle TE support tube onto end of upper TE support tube and pin to lower TE support tube. With all tubes in place, transfer-drill upper TE support tube through holes in middle TE support tube. *Before drilling, ensure that tubes are fully extended, eliminating slack.*

Fabricate flap support per parts drawing. To do so, remove Loc Ring, castle nut, bolt and Teleflex cable from flap horn and raise flap to vertical position. Note distance between pin joining middle and upper TE support tubes and bolt hole for retaining Teleflex to horn; cut flap support to this length, providing allowance for tangs. Assemble flap support per parts drawing, install between TE support tubes and flap.

For standard wing:

Slide middle TE support tube onto lower TE support tube, align holes per parts drawing and size-drill 1/4". Slide upper TE support tube into middle TE support tube, align holes per parts drawing and size-drill 1/4". Cut and debur TE doubler/extension per **Figure 25AA-8A**. Size-drill pre-located holes near top of TE doubler/extension to 1/4". Slide connector into TE doubler/extension, install bushings and secure with hardware per parts drawing.

**FIGURE 25AA-8A**

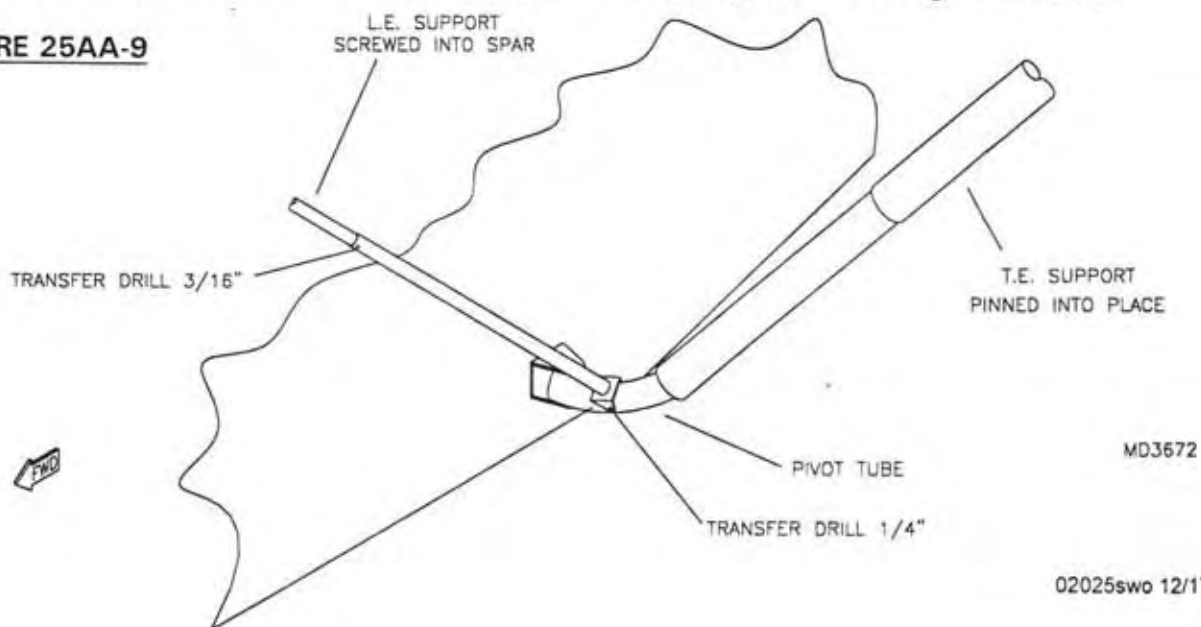


Screw lower TE support tube into fuselage. Pin middle TE support tube to lower TE support tube. Pin TE doubler/extension to aft strut eyebolt. Slip upper TE support tube onto TE doubler/extension and pin to middle TE support tube. With all tubes in place, transfer-drill TE doubler/extension through holes in upper TE support tube. *Before drilling, ensure that tubes are fully extended, eliminating slack.*

Fabricate flap support per parts drawing. To do so, remove Loc Ring, castle nut, bolt and Teleflex cable from flap horn and raise flap to vertical position. Note distance between pin joining middle and upper TE support tubes and bolt hole for retaining Teleflex to horn; cut flap support tube to this length, providing allowance for tangs. Install assembled flap support between TE support tubes and flap.

- Slide LE support tubes together and fit U-bracket at lower end onto pivot tube. Extend upper LE support tube and screw into nut plate in leading edge spar. Locate holes of U-bracket on pivot tube centerline and transfer-drill 1/4" into pivot tube; pin in place. Transfer-drill 3/16" through holes in lower LE support tube and pin LE support tubes together. See **Figure 25AA-9**.

**FIGURE 25AA-9**



For convenience, locate and drill 3/16" hole approximately 1" from upper end of upper LE support tube; collapsed LE support tubes may be pinned together through this hole. Six-inch segments of foam tape may be applied to inboard sides of lower LE support tubes to protect bubble doors from possible abrasion during stowage.

9. Locate hole in wing root seal to allow access for upper LE support tube. Install root seal and extend LE support tubes to check hole location; widen and/or elongate hole as necessary to accommodate upper LE support tube.
10. Folded tail is secured by stabilizer braces. To fabricate, cut two (2) brace tubes (1/2"x.035") to 7½" length and gently squeeze ends in padded vise to flatten; inserting tang into end of tube will ensure that sufficient space remains when flattened. *NOTE: The flattened ends must be on the same plane.* Remove tang and drill #11 on centerline, 1/4" from each end; debur and radius ends. Cut 5/8" segment of primer line tubing, slip segment onto quick pin and insert pin through end of brace; insert another quick pin, sans segment, through other end of brace.
11. Detach lower tail cables from horizontal stabilizers and elevator horns from elevator yoke. Install modified tangs to forward cable attach locations on vertical stabilizer and upper surface of horizontal stabilizers; orient tangs roughly as depicted in parts drawing. Raise horizontal stabilizers to vertical position and secure to vertical stabilizer by fitting stabilizer brace over stabilizer's forward tang and installing quick pin; adjust orientation and bend angle of tangs as required to accommodate brace.
12. Install pin with 5/8" plastic segment to lower end of brace; segment prevents quick pin from extending too far beyond tang and damaging horizontal stabilizer skin.
13. To preclude damaging universal hinge at trailing edge spar/fuselage juncture, check that bolt through inboard hinge of flap is oriented with head facing fuselage.
14. Inside cabin, remove Loc Ring from leading edge Clevis pin; push pin forward, allowing it to be grasped from front of spar. Remove pin from aileron push-pull tubes; pull tubes apart. Pin wing push-pull tube to right-angle bracket on root. Close cabin door.
15. Remove Clevis pin at strut/fuselage juncture; remove leading edge Clevis pin. Pivot wing toward tail.
16. Install Bent ST-16 Tang to the aft underside of the trailing edge spar. *CAUTION: Position the tang as close to aft centerline as possible, yet allow free travel of the aileron.* Rivet the tang even with the aft end of the tailcone. Note distance between tang and center of top longeron when wing is folded. *NOTE: allow approximately 1" clearance between wing and fuselage.* Cut 1/2"x.035" tube to approximate length, allowing margin for error. Gently squeeze one end in padded vise to flatten; as with stabilizer brace, allow sufficient space for fitting over tang. Drill #11 on centerline, 1/4" from end; debur and radius. Pin brace to bent tang on aft spar. Locate unfinished end on top longeron aft of the upper tail gusset and determine finished length. Remove brace from stabilizer, trim to length, flatten end as required, drill #11, debur and radius. Drill #11 vertically through the longeron. Brace is secured to tailcone and wing with quick pins.

Repeat above steps as necessary for remaining wing. Wing supports and braces may be broken down, placed in carryall and stowed in Coyote's baggage compartment. See *Swing Wing Operating Instructions* below.

## S-6ES OPTIONAL SWING WING OPERATING INSTRUCTIONS

Wings may be stowed one-at-a-time as follows.

1. Pin tail braces to aft tangs of vertical stabilizer. Pin stabilizer braces to forward tangs of vertical stabilizer. Detach lower tail cables from fuselage, raise and pin stabilizers to stabilizer braces.
2. Inside cabin, remove Loc Ring from wing leading edge Clevis pin; push pin forward, allowing it to be grasped from front of wing in step 9. Remove pin from aileron push-pull tubes; pull tubes apart. Pin wing push-pull tube to right-angle bracket on root. Close cabin door.
3. Remove screw(s) from wing cuff.
4. Remove Loc Ring, castle nut, bolt and Teleflex cable from flap horn.
5. Screw lower TE support tube to fuselage; pin remaining TE support tubes and flap support together.
6. Attach flap support to flap horn with horn's castle nut, bolt and Loc Ring; leave Teleflex aside.
7. Pin LE support to pivot tube; extend LE support to leading edge spar and screw into nut plate. Insert pin in LE support tubes.
8. Pin TE support to eyebolt in aft strut.
9. Remove Clevis pin at strut/fuselage juncture. Remove wing leading edge Clevis pin. Pivot wing tip to tail.
10. Pin brace to wing tang and fuselage.

Repeat steps 1 through 10 for other wing; reverse steps to unstow.

### **CAUTION!**

*Tricycle gear aircraft may settle onto tail while stowing; be prepared to lower tail gently to ground.*

*Fuel may siphon between tanks and vent from aircraft when parked on uneven surfaces. **TAKE CARE TO AVOID POSSIBLE FUEL HAZARD!***

*Ensure that wings, struts, control surfaces, Teleflex cables, push-pull tubes and hardware are correctly installed before entering aircraft. **CHECK AIRCRAFT THOROUGHLY PRIOR TO FLIGHT!***



## S-6ES OPTIONAL AVIONICS MOUNTS

### ANTENNA BACKING PLATE

The Antenna Backing Plate may be installed before or after covering of the aircraft.

1. Locate the parts shown in the parts manual.
2. Several pilot holes have been located for antenna mounting. Determine location of each antenna and final hole size. **NOTE:** Typically the VHF/COM Antenna will mount on the right and the Transponder Antenna will mount on the left. **CAUTION:** Comply with Emergency Locator Transmitter (ELT) antenna location and cable routing directions. Otherwise unwanted ELT activation may be triggered by the VHF/COM transmission.
3. Position the Antenna Backing Plate, on the belly of the aircraft, between the Station 4 Bottom Crossing and Diagonal Tubes. Be sure the Antenna Backing Plate is flush with the bottom of the belly stringers, or against the skin if the fuselage is already covered.
4. Locate and drill five (5) #30 holes in each flange, on tube centerline. Cleco as you drill. Deburr and rivet. Install antennas during final assembly.

### RADIO MOUNT PLATE

The Instrument Panel must be fit-up prior to installing the Radio Mount Plates. RANS Radio Mount Plates are available in single, dual or triple stack designs.

1. Locate the parts shown in the parts manual.
2. Position the Mount Plates with the short flanges against the Instrument panel. Place the radio trays between the Mount Plates. Center the assembly and drill #30 through the flanges and panel. Cleco in place. Install the radio trays to the Mount Plates. **NOTE:** Allow clearance for the radios to slide in and out freely. Rivet mount plates to the Instrument panel.
3. Mount the forward end of the Mount Plates to the diagonal fuselage brace tubes with cushioned clamps. Hummer Tangs may be needed, depending on the installation.

### HEADSET JACK MOUNT PLATE

The Headset Jack Mount Plate is designed to retain Pilot & Co-pilot headset jacks and 2 aux. power plugs in the Interior Baggage Compartment Panel (KPIN0004).

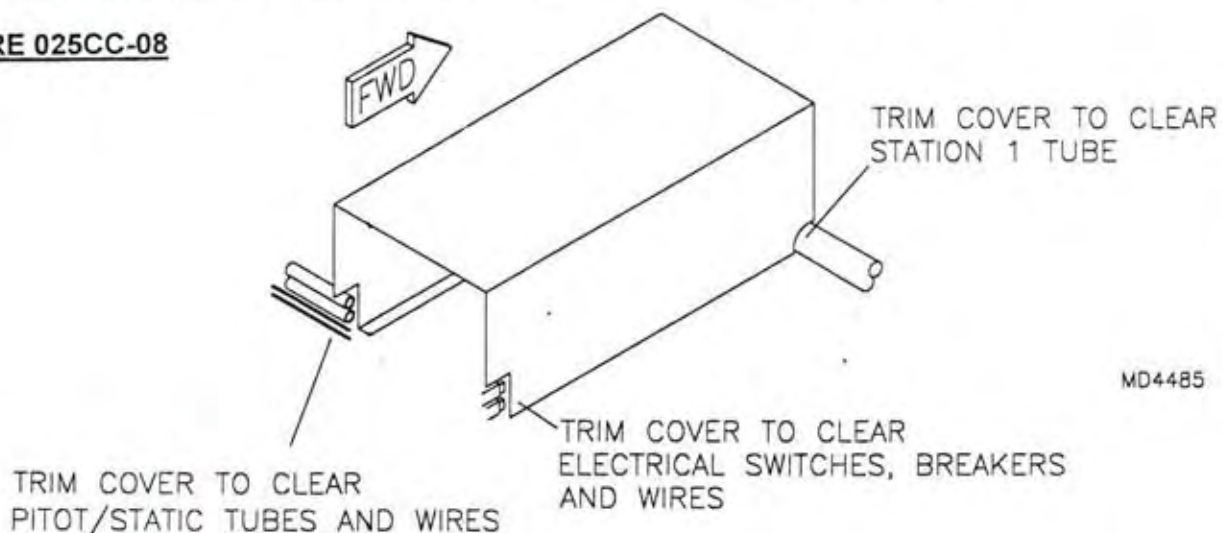
1. Locate the parts shown in the parts manual.
2. Position the top end of the Mount Plate centered and flush with the top of the Baggage Panel on the aft side. This will position the Mount Plate centered behind the seats. **NOTE:** The aux. power plugs are to the bottom.
3. Transfer drill #30 and rivet the Mount Panel. Use the mount panel as a guide and trim out the holes with a Dremel Tool.

## S-6ES COYOTE II OPTIONAL AVIONICS "T" INSTRUMENT PANEL

**NOTE:** The Avionics "T" Instrument and Lower Panels are pre-cut. The panels may be painted or powder coated before final installation to the cockpit cage.

1. Select the parts depicted in the parts drawing.
2. Drill #11 the Aluminum Bushing and cut two (2) 9/16" long bushings.
3. On Station 2, there are two (2) tabs welded to each side. The instrument panel attaches to the **AFT** side of these tabs. Cleco the outer pre-drilled panel holes to the lower Station 2 tab. Transfer drill #30 through the top tabs and Cleco.
4. Attach the Lower Panel to the Instrument Panel's aft side and the aft side of the tab welded to the cockpit's bottom. Center the Lower Panel with the avionics stack cutout and transfer drill #30 through the Lower Panel. **NOTE:** Position the top end of the Lower Panel to clear the avionics stack cutout. Cleco as you drill.
5. Transfer drill #11 through the fuselage tab at the bottom of the Lower Panel and Cleco.
6. Position the Triple Radio Mount Plates against the **FWD** side of the Instrument panel. Rest the longer flange of the Mount Plate on the Panel's Flange. Locate two (2) equally spaced #30 holes per side in the shorter Mount Plate flange. Drill and Cleco. **HINT:** It is best to tape your radio (comm., transponder, GPS, etc.) mounting trays between the Mount plates before drilling. Leave enough room to allow the radio to be slid out of the tray.
7. Slip the cushioned clamps over the diagonal brace tubes. Locate the bushings between the Mount Plates and the Cushion Clamps. **NOTE:** When properly positioned the Mount Plate lower flange will be even with the bottom of the Station 1 crossing tube. Locate and drill #11 through the Mount Plates. Temporarily bolt. Radio mounting trays and/or RANS Optional Map Box may now be permanently attached to the Mount Plates.
8. Locate and drill three (3) equally spaced #11 holes in each lower angle of the Radio Cover. Place Radio Cover over the Mount Plates. Position lower angles under the Mount Plate flanges. Trimming of the forward edge of the Radio Cover will be necessary to clear the Station 1 crossing tube. Trim the aft end to clear electrical components and to facilitate routing of electrical and pitot/static lines. See **FIGURE 025CC-08**. Pitot/static lines and wires may be routed in the space between the Radio Cover and Mount Plates. Transfer drill #11 Mount Plates. Remove Radio Cover and rivet nutplates to Mount Plate flange.

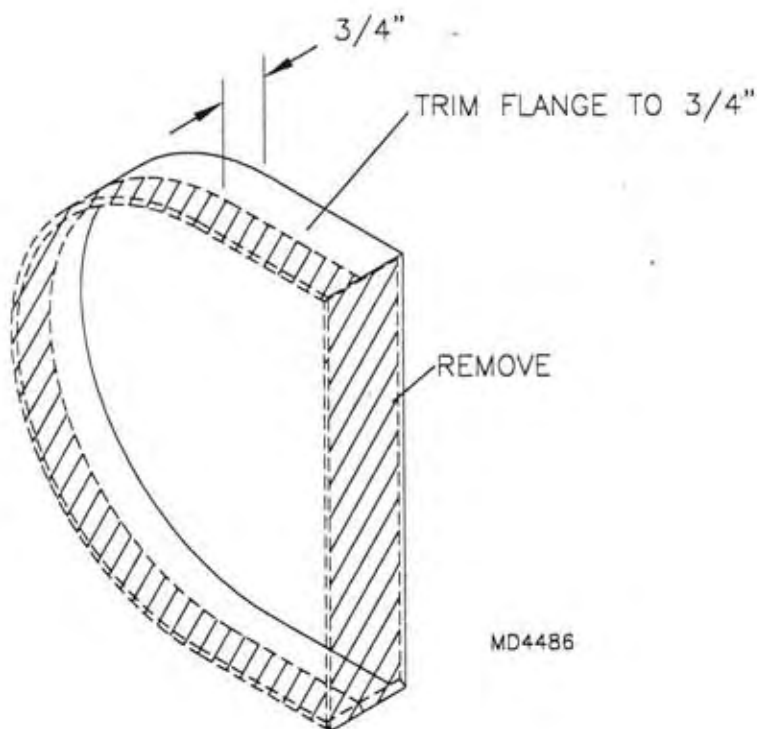
**FIGURE 025CC-08**



MD4485

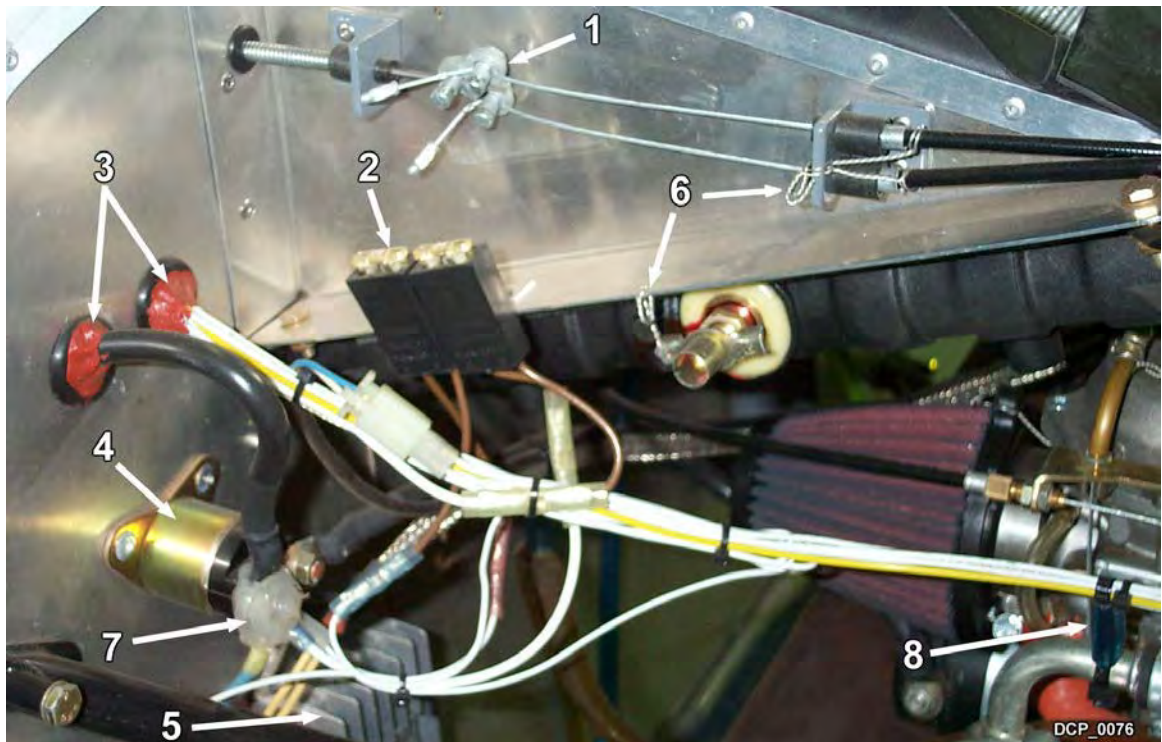
9. The Instrument Panel Covers are positioned on the panel's front side and drilled  $3/32$ " through the panel's top and bottom flanges. Use the pre-drilled holes in the panel to locate the holes in the covers. Make sure the covers are inserted fully into the panel and against the Radio Cover.
10. Trim End Caps per **FIGURE 025CC-10**. Press Caps over covers and equally space three (3) #40 holes. Attach with screws in final assembly.

**FIGURE 025CC-10**



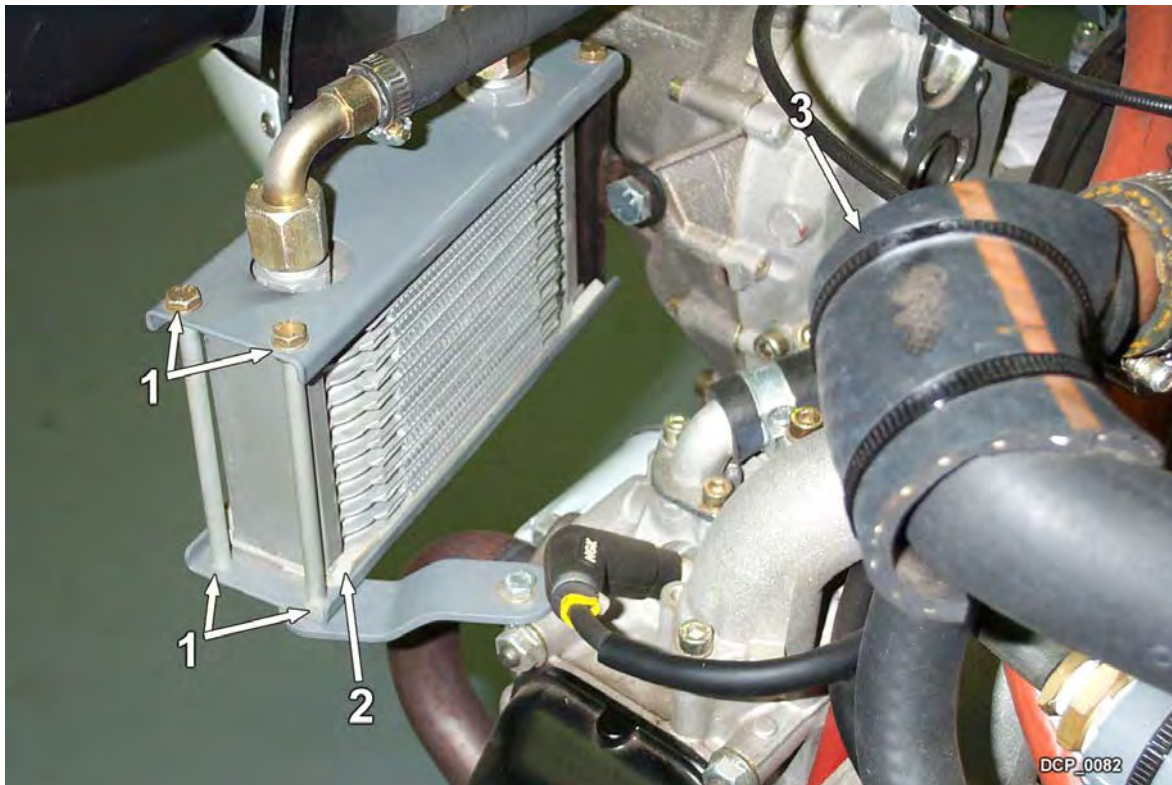
11. The Lower Panel Cover installs the same way as the top panel covers.
12. Instruments and avionics may be wired in or out of aircraft. Rivet and bolt panel assemblies per parts page.
13. Provided with your kit is a special fabric for covering the covers. It is highly recommended to use this fabric. It is made of a special sun-resistant material. The fabric color is designed to allow the least amount of heat transfer to the instruments, as well as reduced glare and reflection. You simply can not do that with paint. Unroll the fabric and lay it on a flat surface. The fabric is the same on either side. Lay the covers over the fabric with the fabric stripes fore and aft. Leave a generous amount of fabric overhang on all edges. Use a spray contact cement to attach the fabric (RANS uses 3M General Trim Adhesive). Trim excess fabric with a razor knife.
14. After all instruments are installed, replace the covers and install the screws. To access the top instrument panel it is not required to remove the covers, only the top screws. Be careful not to scratch the windshield when removing the top screws.
15. If installing an engine without an electrical starter, refer to SECTION 16 – INSTRUMENT PANEL, for Starter Handle Hook installation instructions.

## S-6S & S-6ES – 912 INSTALLATION – 80/100 HP



- |                          |   |
|--------------------------|---|
| 1. THROTTLE              | 5. REGULATOR  |
| 2. BLADE TYPE FUSES      | 6. SAFETY WIRE RADIATOR DRAIN VALVE AND THROTTLE CABLES |
| 3. SEALANT, USE SILICONE | 7. SEALANT, USE SILICONE                                |
| 4. STARTER SOLENOID      | 8. STAND OFFS ARE HANDY TO ROUTE WIRE BUNDLES           |

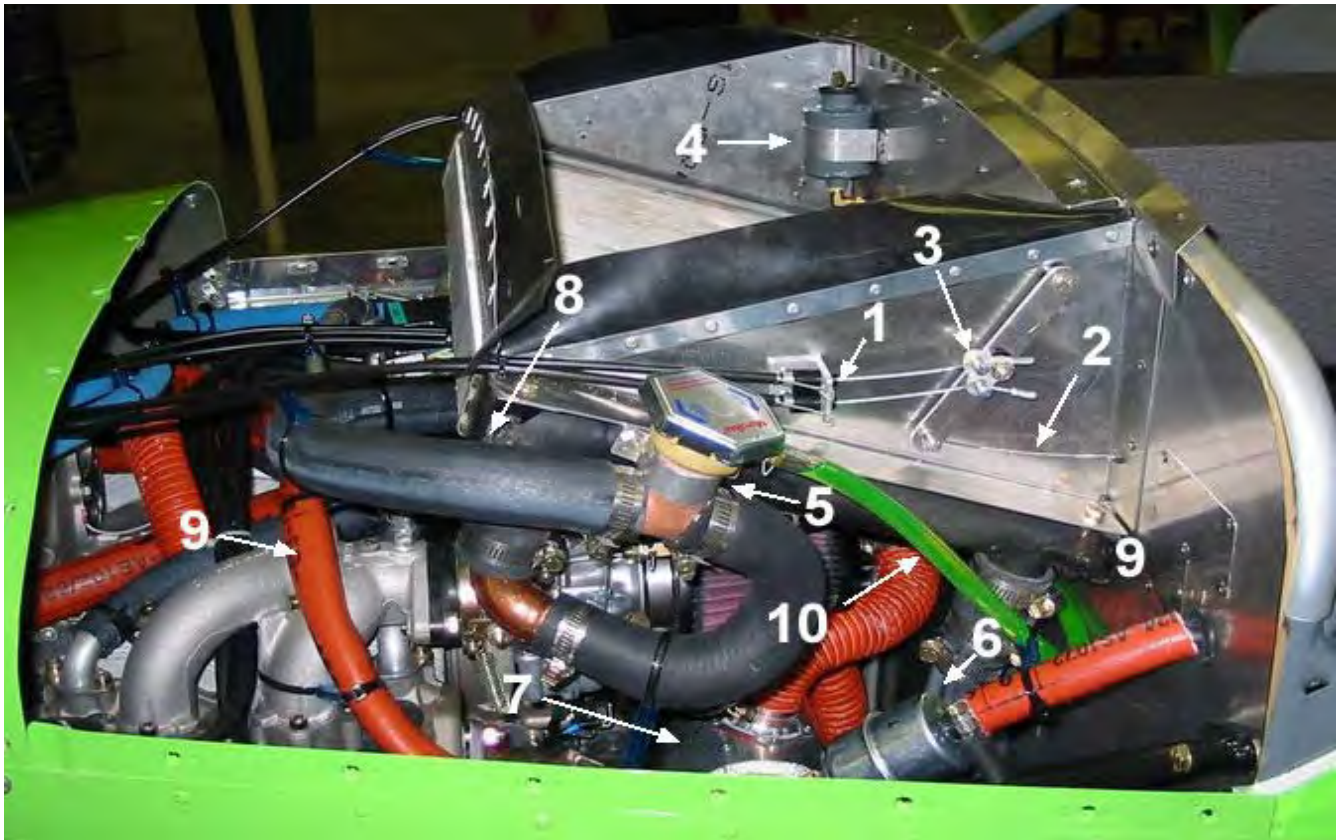
S-6S & S-6ES – 912 INSTALLATION – 80/100 HP  
OIL COOLER INSTALLATION



1. LOC-TITE ALL OIL COOLER MOUNTING
2. FOAM RUBBER PADS COOLER

3. ANTI-CHAFE, USE COOLANT HOSE SCRAP

## S-6ES – 912 INSTALLATION – 80/100 HP



1. SAFETY WIRE CHOKE
3. LOC-TITE SCREWS
5. FILLER TEE
7. HEATER WRAP
9. FIRESLEEVE ON FUEL LINE IS A GOOD IDEA

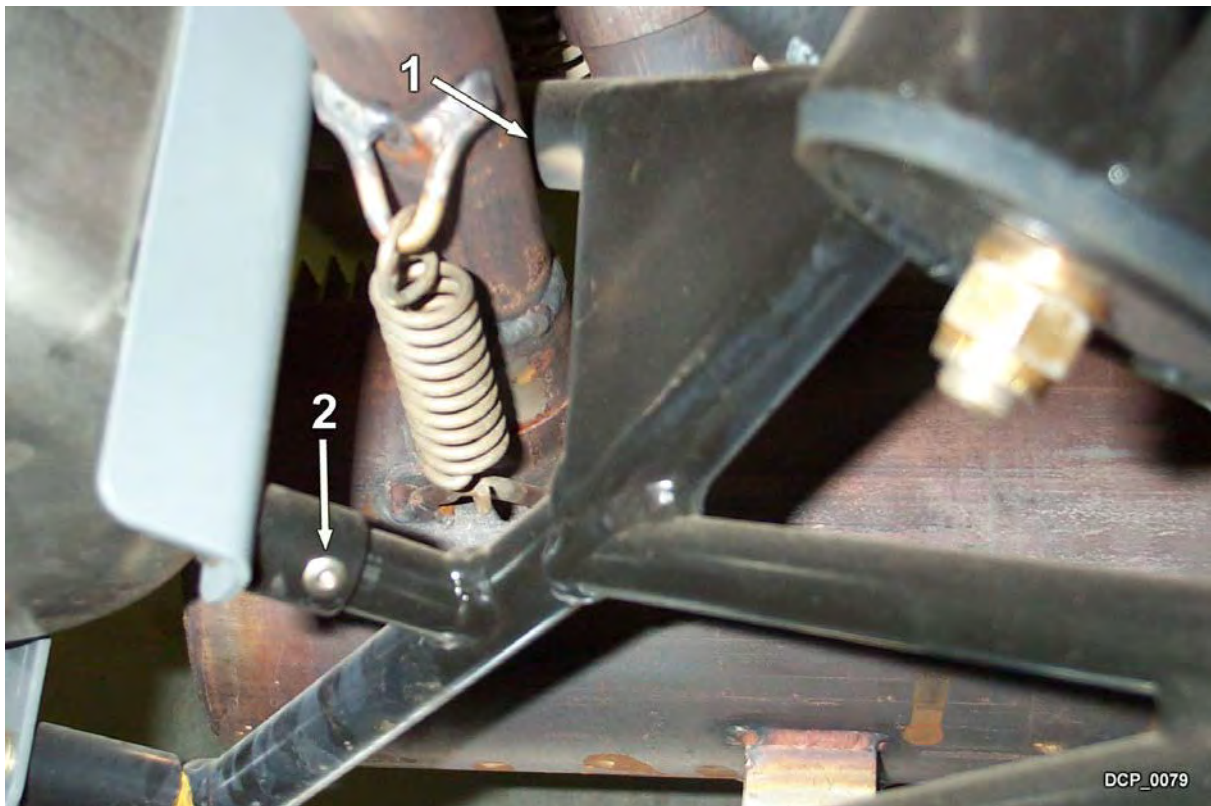
2. CHOKE WIRE
4. BRAKE FLUID RESERVOIR
6. FUEL FILTER
8. BLEEDER SCREW (BEHIND HOSE)
10. COOLANT OVERFLOW TUBE

S-6S & S-6ES – 912 INSTALLATION – 80/100 HP  
LANDING LIGHT INSTALLED ON 912



1. ECONO LANDING LIGHT FROM WAL-MART, BLAZER PROJECTOR BEAM FOG LAMP SYSTEM (C4072K)

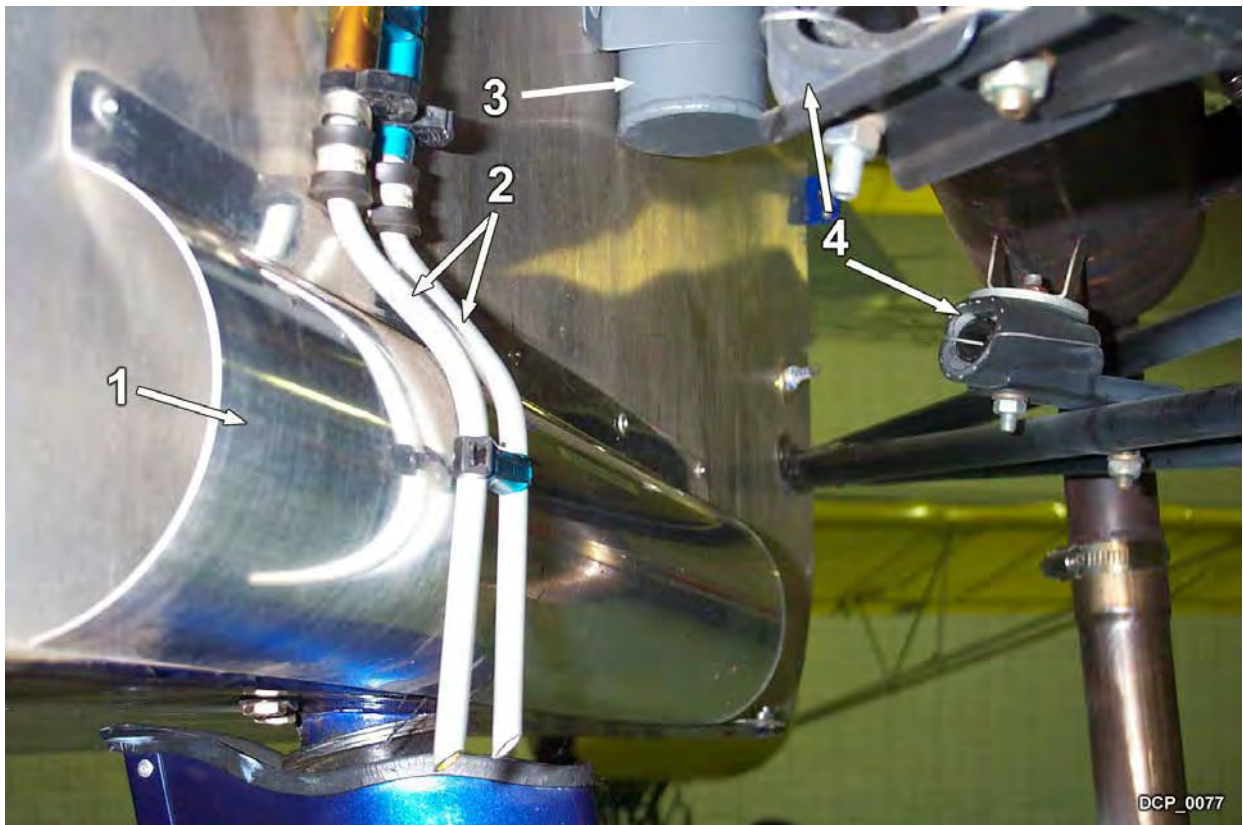
S-6S & S-6ES – 912 INSTALLATION – 80/100 HP



1. CLEARANCES ARE TIGHT SOME DIMPLING OF EXHAUST TUBE MAY BE REQUIRED
2. 1/8" DIAMETER STAINLESS STEEL RIVET SECURES OIL TANK MOUNT IN POSITION



S-6S & S-6ES – 912 INSTALLATION – 80/100 HP



- 1. VENTURI BULB
- 2. METAL OVERFLOW TUBES

- 3. COOLANT OVERFLOW BOTTLE
- 4. MUFFLER MOUNT, NOTE: CHANNEL FLANGE POSITION

S-6S & S-6ES – 912 INSTALLATION – 80/100 HP



1. RIVET HOLDS POSITION OF CLAMP

2. MUFFLER IS CLOSE BUT WILL CLEAR